



CPV Valley Energy Center
3330 Route 6
Middletown, NY 10940

August 24, 2018

Regional Air Pollution Control Engineer
NYSDEC Region 3
21 South Putt Corners Road
New Paltz, NY 12561
Certified Mail: 7017 0190 0000 0941 2706

Division of Air Resources
NYSDEC – Bureau of Quality Assurance
625 Broadway
Albany, NY 12233-3258
Certified Mail: 7017 0190 0000 0941 2713

USEPA Region II
Air Compliance Branch
290 Broadway
New York, NY 10007-1866
Certified Mail: 7017 0190 0000 0941 2720

John Petronella
NYSDEC Region 3 Permit Administrator
21 South Putt Corners Rd.
New Paltz, NY 12561-1620
Certified Mail: 7017 1090 0000 0941 2737

Re: CPV Valley Energy Center
Title V and Title IV Acid Rain Permit Application

Dear Sir / Madam:

CPV Valley Energy Center is submitting the Title V and Title IV Acid Rain permit application to New York State Department of Environmental Conservation (NYSDEC) in accordance with the Title 6 of the New York Codes, Rules and Regulations (NYCRR) Section 201-6.2. A completed Title V permit application and supporting documentation is included in **Attachment 1**. The Title IV Acid Rain permit application is included in **Attachment 2**. CPV Valley Energy Center looks forward to working with the Department on the Title IV and Title V application process. If you have any questions or require further information regarding this submission, please feel free to contact me at 781-848-2202.

Sincerely,

Don Atwood
Competitive Power Ventures, Inc.
Asset Manager Representative

CC: Ben Stanley
Christopher Hogan
Chris Allgeier



CPV Valley Energy Center
50 Braintree Hill Office Park
Suite 300
Braintree, MA 02184

ATTACHMENT 1

Title V Certification And Application Forms

New York State Department of Environmental Conservation
Air Permit Application



Department of
**Environmental
 Conservation**

DEC ID											
3	-	3	3	5	6	-	0	0	1	3	6

Application ID												
-												

Application Type	
State Facility	* Title V

Section I - Certification

Certification	
I certify under penalty of law that this document and all attachments were prepared under my direction or supervision in accordance with a system designed to assure that qualified personnel properly gather and evaluate the information submitted. Based on my inquiry of the person or persons directly responsible for gathering the information required to complete this application, I believe the information is true, accurate, and complete. I am aware that there are significant penalties for submitting false information, including the possibility of fines and imprisonment for knowing violations.	
Responsible Official Donald Atwood	Title Asset Management Rep.
Signature <i>[Signature]</i>	Date 8-24-2018
Professional Engineer Certification	
I certify under penalty of law that I have personally examined, and am familiar with, the statements and information submitted in this document and all its attachments as they pertain to the practice of engineering. I am aware that there are significant penalties for submitting false information, including the possibility of fines and imprisonment for knowing violations.	
Professional Engineer Peter T. Belmont	NYS License No. 0825409
Signature <i>[Signature]</i>	Date 8-27-2018

Section II - Identification Information

Type of Permit Action Requested			
<input checked="" type="checkbox"/> New	<input type="checkbox"/> Renewal	<input type="checkbox"/> Significant Modification	<input type="checkbox"/> Administrative Amendment
<input type="checkbox"/> Minor Modification	Application for the construction of a new facility		
Application involves the construction of new emission unit(s)			
Facility Information			
Name CPV Valley Energy Center			
Location Address 3330 Route 6			
* City / Town / Village Middletown, NY			Zip 10940
Owner/Firm Information			Business Taxpayer ID
Name CPV Valley LLC.			
Street Address 8403 Colesville Road Suite 915			
City Silver Spring	State/Province MD	Country US	Zip 20910
Owner Classification: <input type="checkbox"/> Federal <input type="checkbox"/> State <input type="checkbox"/> Municipal <input checked="" type="checkbox"/> Corporation/Partnership <input type="checkbox"/> Individual			
Owner/Firm Contact Information			
Name Donald Atwood			Phone 781-848-2202
E-mail Address Datwood@cpv.com			Fax
Affiliation Asset Management Representative			Title Asset Management Rep.
Street Address 50 Braintree Hill Office Park Suite 300			
City Braintree	State/Province MA	Country US	Zip 02184
Facility Contact Information			
Name Ben Stanley			Phone 845-649-8300
E-mail Address b.stanley@dgc-ops.com			Fax
Affiliation Operator			Title Plant Manager
Street Address 3330 Route 6			
City Middletown	State/Province NY	Country US	Zip 10940

New York State Department of Environmental Conservation

Air Permit Application



Department of Environmental Conservation

DEC ID											
3	-	3	3	5	6	-	0	0	1	3	6

Project Description	* Continuation Sheet(s)
CPV Valley, LLC owns and operates the CPV Valley Energy Center, a 680 megawatt (MW) natural gas-fired electric generating facility. The CPV Valley Energy Center will use ultra-low sulfur distillate oil for back-up for reliability purposes. The CPV facility will use "combined cycle" generation technology and will be comprised of two combined-cycle units, each consisting of a combustion turbine generator (CTG), a Heat Recovery Steam Generator (HRSG) with supplemental duct firing, and a steam turbine generator (STG).	

Section III - Facility Information

Facility Classification					
Hospital	Residential	Educational/Institutional	Commercial	Industrial	* Utility

Affected States (Title V Applications Only)					
Vermont	Massachusetts	Rhode Island	* Pennsylvania	Tribal Land: <small>N/A</small>	
New Hampshire	* Connecticut	* New Jersey	Ohio	Tribal Land: <small>N/A</small>	

SIC Code(s)			NAICS Code(s)		
4911			221112		

Facility Description	* Continuation Sheet(s)
The CPV Valley Energy Center consists of two dual fuel-fired Siemens F-class combustion turbine generators (CTGs), with a nominal heat input of 2,234 mm Btu/hr, each when operating on natural gas at base load, two 500 mmBtu/hr supplementary natural gas-fired duct burners, two heat recovery steam generators.	

Compliance Statements (Title V Applications Only)

I certify that as of the date of this application the facility is in compliance with all applicable requirements. * Yes No

If one or more emission units at the facility are not in compliance with all applicable requirements at the time of signing this application (the 'NO' box must be checked), the noncomplying units must be identified in the "Compliance Plan" block on page 8 of this form along with the compliance plan information required. For all emission units at the facility that are operating in compliance with all applicable requirements, complete the following:

- * This facility will continue to be operated and maintained in such a manner as to assure compliance for the duration of the permit, except those emission units referenced in the compliance plan portion of this application.
- * For all emission units subject to any applicable requirements that will become effective during the term of the permit, this facility will meet such requirements on a timely basis.
- * Compliance certification reports will be submitted at least once per year. Each report will certify compliance status with respect to each applicable requirement, and the method used to determine the status.

Facility Applicable Federal Requirements										* Continuation Sheet(s)
Title	Type	Part	Subpart	Section	Subdivision	Paragraph	Subparagraph	Clause	Subclause	
40	CFR	82	F							
40	CFR	72	A							
40	CFR	60	A	3,7,8,11						
40	CFR	60	A	12,13,19						

Facility State Only Requirements										* Continuation Sheet(s)
Title	Type	Part	Subpart	Section	Subdivision	Paragraph	Subparagraph	Clause	Subclause	
6	NYCRR	293								
6	NYCRR	202	1							
6	NYCRR	202	2							
6	NYCRR	621								

New York State Department of Environmental Conservation
Air Permit Application Form

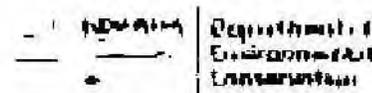

DEC ID											
3	-	3	3	5	6	-	0	0	1	3	6

Section II - Identification Information

Project Description (continuation)

Auxiliary equipment includes a low nitrogen oxide (NOx) natural gas-fired auxiliary boiler, needed to keep the HRSGs warm during periods of turbine shutdown and to provide sealing steam during startups. The stacks for the facility are 275 feet tall. The project is located on an approximately 122-acre site in Wawayanda, Orange County, New York. The project activities are located on an approximately 21-acre area that is bounded to the east by State Route 17M/6; to the north by State Route 6 and to the south by Interstate 84.

**New York State Department of Environmental Conservation
Air Permit Application Form**

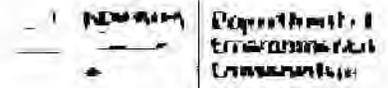

DEC ID											
3	-	3	3	5	6	-	0	0	1	3	6

Section III - Facility Information

Facility Description (continuation)

(HRSGs) and a single steam turbine generator (STG). Supporting ancillary equipment includes a 48.1 mmBtu/hr natural gas fired auxiliary boiler, a 10.08 mmBtu/hr ULSD emergency generator, one dew point heater with two 4.48 mmBtu/hr fuel gas burners and a 1.96 mmBtu/hr ULSD fire water pump engine. The CTGs are fueled by natural gas. Ultra-low sulfur diesel may be used as backup fuel for up to 720 hours per year per turbine. The duct burners will fire natural gas exclusively. The CTGs utilize dry low-NOx (DLN) combustors for gas firing and water injection for control of nitrogen oxides (NOx) when firing ultra-low sulfur diesel. Selective catalytic reduction (SCRs) systems are used to further control NOx emissions. Oxidation catalysts and efficient combustion controls will be used to control emissions of carbon monoxide (CO) as well as volatile organic compounds (VOCs). Emissions of SO2 and PM/PM-10 are minimized through the use of pipeline natural gas and ULSD as backup, as well as efficient combustion controls. Upon leaving the SCRs, turbine gases are directed to individual stacks at 275 feet above grade with a flue diameter of 19 feet. In addition, CTGs inlet air will be cooled using an evaporative cooler when ambient temperatures are high, to improve CTGs efficiency.

The auxiliary boiler employs low-NOx burners (LNB) and flue gas recirculation (FGR) to control emissions of NOx. The auxiliary boiler will operate as needed for any start up condition to keep the HRSG warm during periods of turbine shutdown and to provide sealing steam to the steam turbine in the case of warm and hot startups. Total boiler hours for the facility will be limited to 2,000 hours per year.

The dew point fuel gas heater employs two forced draft burners to reduce NOx emissions. The unit will heat the natural gas to optimum firing temperature. The dew point heaters is proposed to operate up to 8,760 hours per year.

The emergency diesel fire pump will provide on-site fire fighting capability independent of the utility grid. The emergency diesel generator will be operated only for testing and to maintain operational readiness or if needed for emergency operation. Each emergency engine will be allowed to operate for up to 500 hours per year.

A 1.3 megawatt or similar emergency mobile back up may be used only for testing and to maintain operational readiness or it needed for emergency operation.

The five space heaters are used inside the generation buildings for temperature regulation.

The 930,900 gallon fuel oil storage tank, 600 gallon emergency diesel generator storage tank, and 500 gallon emergency diesel fire pump storage tank are maintained at the facility.

Only the facility's combustion turbines, duct burners and auxiliary boiler are subject to NYSDEC NOx RACT provisions.

The dew point heater, the emergency diesel generator, the emergency diesel fire pump, the five space heaters, the mobile backup generator, the fuel oil storage tank, and the emergency diesel storage tanks are exempt activities pursuant to Part 201-3.2.

New York State Department of Environmental Conservation
Air Permit Application Form

Department of Environmental Conservation
 Air Permit Application Form

DEC ID											
3	-	3	3	5	6	-	0	0	1	3	6

Section III - Facility Information

Facility State Only Requirements (continuation)									
Title	Type	Part	Subpart	Section	Subdivision	Paragraph	Subparagraph	Clause	Subclause
6	NYCRR	200	3						
6	NYCRR	200	5						
6	NYCRR	200	6						
6	NYCRR	200	7						
6	NYCRR	201	1						
6	NYCRR	201	2						
6	NYCRR	201	3	1					
6	NYCRR	201	3	2					
6	NYCRR	201	3	3					
6	NYCRR	201	6	1	a				
6	NYCRR	201	6	1	b				
6	NYCRR	201	6	2,3					
6	NYCRR	201	6	4					
6	NYCRR	201	6	5					
6	NYCRR	201	6	6					
6	NYCRR	202	1	1					
6	NYCRR	202	1	2					
6	NYCRR	202	1	3					
6	NYCRR	202	1	5					
6	NYCRR	207							
6	NYCRR	211	1,2						
6	NYCRR	215							
6	NYCRR	225	1	6	a				
6	NYCRR	225	1	6	b				
6	NYCRR	225	1	2	h				
6	NYCRR	227	1,2						
6	NYCRR	231	2	1					
6	NYCRR	231	2	2					
6	NYCRR	231	2	3					
6	NYCRR	231	2	4					
6	NYCRR	231	2	5					

**New York State Department of Environmental Conservation
Air Permit Application**

 Department of
Environmental
Conservation

DEC ID											
3	-	3	3	5	6	-	0	0	1	3	6

Facility Compliance Certification										* Continuation Sheet(s)
Rule Citation										
Title	Type	Part	Subpart	Section	Subdivision	Paragraph	Subparagraph	Clause	Subclause	
6	NYCRR	227	1	3	a					
* Applicable Federal Requirement			Capping	CAS Number		Contaminant Name				
_ State Only Requirement										
Monitoring Information										
* Work Practice Involving Specific Operations			Ambient Air Monitoring			Record Keeping/Maintenance Procedures				
Compliance Activity Description										
<p>No owner or operator of a combustion installation shall operate the installation in such a way to emit greater than 20 percent opacity except for one six minute period per hour, not to exceed 27 percent, based upon the six minute average in reference test Method 9 in Appendix A of 40 CFR 60. The opacity standards apply at all times except during periods of start up, shutdown, and malfunction; and all other applicable conditions cited in section 40CFR 60.11.</p>										
Work Practice Type Code	Process Material				Reference Test Method					
	Code	Description								
					40 CFR 60, Method 9					
Monitored Parameter				Manufacturer's Name/Model Number						
Code	Description									
01	Opacity									
Limit		Limit Units								
Upper	Lower	Code	Description							
20	0	136	Percent							
Averaging Method			Monitoring Frequency			Reporting Requirements				
Code	Description		Code	Description		Code	Description			
18	6-min average		14	As required		10	Upon Request			
Facility Emissions Summary										* Continuation Sheet(s)
CAS Number	Contaminant Name				Potential to Emit (tons/yr)	Actual Emissions (pounds/yr)				
ONY075 - 00 - 5	PM-10				95.0					
ONY750 - 02 - 5	PM-2.5				95.0					
007446 - 09 - 5	Sulfur Dioxide				42.0					
ONY210 - 00 - 0	Oxides of Nitrogen				183.0					
000630 - 08 - 0	Carbon Monoxide				341.5					
007439 - 92 - 1	Lead (elemental)				0.02					
ONY998 - 00 - 0	Total Volatile Organic Compounds				64.0					
ONY100 - 00 - 0	Total Hazardous Air Pollutants				13.94					
ONY750 - 00 - 0	Carbon Dioxide Equivalents				2,164,438.0					
007664-93-9	Sulfuric Acid				13.0					
007664-41-7	Ammonia				104.8					

New York State Department of Environmental Conservation
Air Permit Application Form

NYSDOCS Form 136-A
 (12/01/03)
 136-A

DEC ID											
3	-	3	3	5	6	-	0	0	1	3	6

Section III - Facility Information

Facility Emissions Summary (continuation)				
CAS No.	Contaminant Name	PTE		Actual (lbs/yr)
		(lbs/yr)	Range	
106-99-0	1,3 Butadiene	6.50E+01	Y	
71-55-6	1, 1, 1-Trichloroethane	0.00E+00	Y	
56-49-5	3-Methylchloranthrene	4.49E-03	Y	
57-97-6	7, 12-Dimethylbenz(a)anthracene	4.40E-02	Y	
83-32-9	Acenaphthene	4.50E+01	Y	
208-96-8	Acenaphthylene	3.62E+00	Y	
75-07-0	Acetaldehyde	1.57E+03	Y	
107-02-8	Acrolein	2.50E+02	Y	
120-12-7	Anthracene	6.54E+00	Y	
07440-38-2	Arsenic	3.46E+01	Y	
56-55-3	Benz(a)anthracene	1.11E+01	Y	
71-43-2	Benzene	2.12E+03	Y	
50-32-8	Benzo(a)pyrene	2.24E+00	Y	
205-99-2	Benzo(b)fluoranthene	6.02E+00	Y	
191-24-2	Benzo(g, h, i)perylene	6.54E+00	Y	
207-08-9	Benzo(k)fluoranthene	6.02E+00	Y	
07740-41-7	Beryllium	9.90E-01	Y	
07740-43-9	Cadmium	1.78E+01	Y	
07740-47-3	Chromium	3.78E+01	Y	
218-01-9	Chrysene	7.82E+00	Y	
07740-48-4	Cobalt	2.30E-01	Y	
53-70-3	Dibenzo(a, h)anthracene	5.38E+00	Y	
106-46-7	Dichlorobenzene	3.30E+00	Y	
100-41-4	Ethylbenzene	1.25E+03	Y	
206-44-0	Fluoranthene	1.48E+01	Y	
7782-96-5	Fluorene	1.39E+01	Y	
50-00-0	Formaldehyde	5.02E+03	Y	
110-54-3	Hexane	4.94E+03	Y	
193-39-5	Indeno(1,2,3-cd)pyrene	7.34E+00	Y	
07439-92-1	Lead	4.46E+01	Y	

Continuation Sheet 1 of 2

New York State Department of Environmental Conservation
Air Permit Application



Department of Environmental Conservation

DEC ID											
3	-	3	3	5	6	-	0	0	1	3	6

Section IV - Emission Unit Information

Emission Unit Description											Continuation Sheet(s)	
Emission Unit	U	-	0	0	0	0	1					
<p>One Siemens SGT6-5000 F-Class combustion turbine which has a nominal rating of 1,998 mm Btu/hr at 51 °F (2,234 mmBtu/hr at -5°F) on natural gas and (2,145 mmBtu/hr at -5°F) on fuel oil (<0.0015% sulfur). The turbine is equipped with dry low-NOx combustors, steam injection, SCR and oxidation catalyst emission controls. This emission unit also contains a natural gas-fired duct burner rated at a nominal capacity of 500 mmBtu/hr.</p>												

Building Information				Continuation Sheet(s)	
Building ID	Building Name	Length (ft)	Width (ft)	Orientation	
GEN01	Generation Building	300	260	North	
ACC01	Air Cooled Condenser	296	327	North	
HRSG01	Heat Recovery Steam Generator - Inside Generation Building	160	105	North	

Emission Unit	Emission Unit Emissions Summary				* Continuation Sheet(s)	
U - 0 0 0 0 1						
CAS Number	Contaminant Name					
ONY075-00 - 0	Particulates					
ERP (lbs/yr)	Potential to Emit		Actual Emissions			
	(lbs/hr)	(lbs/yr)	(lbs/hr)	(lbs/yr)		
		94,200.0				
CAS Number	Contaminant Name					
ONY075 - 00 - 5	PM-10					
ERP (lbs/yr)	Potential to Emit		Actual Emissions			
	(lbs/hr)	(lbs/yr)	(lbs/hr)	(lbs/yr)		
		94,200.0				
CAS Number	Contaminant Name					
ONY750 - 02 - 5	PM-2.5					
ERP (lbs/yr)	Potential to Emit		Actual Emissions			
	(lbs/hr)	(lbs/yr)	(lbs/hr)	(lbs/yr)		
		94,200.0				
CAS Number	Contaminant Name					
ONY210 - 00 - 0	Oxides of Nitrogen					
ERP (lbs/yr)	Potential to Emit		Actual Emissions			
	(lbs/hr)	(lbs/yr)	(lbs/hr)	(lbs/yr)		
		174,900.0				

New York State Department of Environmental Conservation
Air Permit Application Form

Department of Environmental Conservation

DEC ID											
3	-	3	3	5	6	-	0	0	1	3	6

Section IV - Emission Unit Information

Emission Unit		Emission Unit Emissions Summary (continuation)			
U - 000001					
CAS No.		Contaminant Name			
000630 - 08 - 0		Carbon Monoxide			
ERP (lbs/yr)	PTE Emissions		Actual Emissions		
	(lbs/hr)	(lbs/yr)	(lbs/hr)	(lbs/yr)	
		334,000.0			
CAS No.		Contaminant Name			
007446 - 09 - 5		Sulfur Dioxide			
ERP (lbs/yr)	PTE Emissions		Actual Emissions		
	(lbs/hr)	(lbs/yr)	(lbs/hr)	(lbs/yr)	
		41,000.0			
CAS No.		Contaminant Name			
0NY998 - 00 - 0		Volatile Organic Compounds			
ERP (lbs/yr)	PTE Emissions		Actual Emissions		
	(lbs/hr)	(lbs/yr)	(lbs/hr)	(lbs/yr)	
		62,800.0			
CAS No.		Contaminant Name			
0NY100 - 00 - 0		Total Hazardous Air Pollutants			
ERP (lbs/yr)	PTE Emissions		Actual Emissions		
	(lbs/hr)	(lbs/yr)	(lbs/hr)	(lbs/yr)	
		13,770.0			
CAS No.		Contaminant Name			
0NY750 - 00 - 0		Carbon Dioxide Equivalents			
ERP (lbs/yr)	PTE Emissions		Actual Emissions		
	(lbs/hr)	(lbs/yr)	(lbs/hr)	(lbs/yr)	
		2,164,438,000.0			
CAS No.		Contaminant Name			
007664-93-9		Sulfuric Acid			
ERP (lbs/yr)	PTE Emissions		Actual Emissions		
	(lbs/hr)	(lbs/yr)	(lbs/hr)	(lbs/yr)	
		12,600.0			
CAS No.		Contaminant Name			
007664-41-7		Ammonia			
ERP (lbs/yr)	PTE Emissions		Actual Emissions		
	(lbs/hr)	(lbs/yr)	(lbs/hr)	(lbs/yr)	
		104,800.0			

New York State Department of Environmental Conservation
Air Permit Application Form

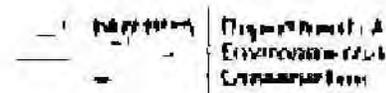

DEC ID											
3	-	3	3	5	6	-	0	0	1	3	6

Section IV - Emission Unit Information

Emission Unit		Emission Unit Emissions Summary (continuation)			
U - 000001					
CAS No.		Contaminant Name			
007439 - 92 - 1		Lead (elemental)			
ERP (lbs/yr)	PTE Emissions		Actual Emissions		
	(lbs/hr)	(lbs/yr)	(lbs/hr)	(lbs/yr)	
		22.30			
CAS No.		Contaminant Name			
ERP (lbs/yr)	PTE Emissions		Actual Emissions		
	(lbs/hr)	(lbs/yr)	(lbs/hr)	(lbs/yr)	
CAS No.		Contaminant Name			
ERP (lbs/yr)	PTE Emissions		Actual Emissions		
	(lbs/hr)	(lbs/yr)	(lbs/hr)	(lbs/yr)	
CAS No.		Contaminant Name			
ERP (lbs/yr)	PTE Emissions		Actual Emissions		
	(lbs/hr)	(lbs/yr)	(lbs/hr)	(lbs/yr)	
CAS No.		Contaminant Name			
ERP (lbs/yr)	PTE Emissions		Actual Emissions		
	(lbs/hr)	(lbs/yr)	(lbs/hr)	(lbs/yr)	
CAS No.		Contaminant Name			
ERP (lbs/yr)	PTE Emissions		Actual Emissions		
	(lbs/hr)	(lbs/yr)	(lbs/hr)	(lbs/yr)	
CAS No.		Contaminant Name			
ERP (lbs/yr)	PTE Emissions		Actual Emissions		
	(lbs/hr)	(lbs/yr)	(lbs/hr)	(lbs/yr)	

**New York State Department of Environmental Conservation
Air Permit Application**



Department of
Environmental
Conservation

DEC ID											
3	-	3	3	5	6	-	0	0	1	3	6

Emission Point Information							Continuation Sheet(s)
Emission Point							E P 0 0 1
Ground Elevation (ft)	Height (ft)	Height Above Structure (ft)	Inside Diameter (in)	Exit Temp. (°F)	Cross Section		
					Length (in)	Width (in)	
496	275	140	228	195			
Exit Velocity (FPS)	Exit Flow (ACFM)	NYTM (E) (KM)	NYTM (N) (KM)	Building	Distance to Property Line (ft)	Date of Removal	
74.26	1,310,911	546.98048	4584.69287		178		
Emission Point							
Ground Elevation (ft)	Height (ft)	Height Above Structure (ft)	Inside Diameter (in)	Exit Temp. (°F)	Cross Section		
					Length (in)	Width (in)	
Exit Velocity (FPS)	Exit Flow (ACFM)	NYTM (E) (KM)	NYTM (N) (KM)	Building	Distance to Property Line (ft)	Date of Removal	
Emission Point							
Ground Elevation (ft)	Height (ft)	Height Above Structure (ft)	Inside Diameter (in)	Exit Temp. (°F)	Cross Section		
					Length (in)	Width (in)	
Exit Velocity (FPS)	Exit Flow (ACFM)	NYTM (E) (KM)	NYTM (N) (KM)	Building	Distance to Property Line (ft)	Date of Removal	

Emission Source/Control Information							* Continuation Sheet(s)	
Emission Source		Date of Construction	Date of Operation	Date of Removal	Control Type		Manufacturer's Name/Model Number	
ID	Type				Code	Description		
C	T 0 0 1	08/2015	01/2018				Siemens SGT6-5000 Class-F Turbine	
Design Capacity	Design Capacity Units			Waste Feed		Waste Type		
	Code	Description		Code	Description	Code	Description	
2234	25	mmBtu/hr						
Emission Source		Date of Construction	Date of Operation	Date of Removal	Control Type		Manufacturer's Name/Model Number	
ID	Type				Code	Description		
D	B 0 0 1	08/2015	01/2018				Fomey Duct Burner	
Design Capacity	Design Capacity Units			Waste Feed		Waste Type		
	Code	Description		Code	Description	Code	Description	
500	25	mmBtu/hr						
Emission Source		Date of Construction	Date of Operation	Date of Removal	Control Type		Manufacturer's Name/Model Number	
ID	Type				Code	Description		
D	L N 0 1	08/2015	01/2018		103	dry low NOx burner		
Design Capacity	Design Capacity Units			Waste Feed		Waste Type		
	Code	Description		Code	Description	Code	Description	

New York State Department of Environmental Conservation
Air Permit Application Form

NY State Department of Environmental Conservation

DEC ID											
3	-	3	3	5	6	-	0	0	1	3	6

Section IV - Emission Unit Information

Emission Source/Control (continuation)										
Emission Unit		U - 0 0 0 0 1								
Emission Source		Date of Construction	Date of Operation	Date of Removal	Control Type		Manufacturer's Name/Model No.			
ID	Type				Code	Description				
STI01	K	08/2015	01/2018		028	steam or water injection				
Design Capacity	Design Capacity Units				Waste Feed		Waste Type			
	Code	Description			Code	Description	Code	Description		
Emission Source		Date of Construction	Date of Operation	Date of Removal	Control Type		Manufacturer's Name/Model No.			
ID	Type				Code	Description				
SCR01	K	08/2015	01/2018		033	selective catalytic reduction (SCR)	YARA SCR			
Design Capacity	Design Capacity Units				Waste Feed		Waste Type			
	Code	Description			Code	Description	Code	Description		
Emission Source		Date of Construction	Date of Operation	Date of Removal	Control Type		Manufacturer's Name/Model No.			
ID	Type				Code	Description				
OXY01	K	08/2015	01/2018		110	catalytic oxidation	SYNERGY			
Design Capacity	Design Capacity Units				Waste Feed		Waste Type			
	Code	Description			Code	Description	Code	Description		
Emission Source		Date of Construction	Date of Operation	Date of Removal	Control Type		Manufacturer's Name/Model No.			
ID	Type				Code	Description				
Design Capacity	Design Capacity Units				Waste Feed		Waste Type			
	Code	Description			Code	Description	Code	Description		
Emission Source		Date of Construction	Date of Operation	Date of Removal	Control Type		Manufacturer's Name/Model No.			
ID	Type				Code	Description				
Design Capacity	Design Capacity Units				Waste Feed		Waste Type			
	Code	Description			Code	Description	Code	Description		

**New York State Department of Environmental Conservation
Air Permit Application**



Department of Environmental Conservation

DEC ID											
3	-	3	3	5	6	-	0	0	1	3	6

Process Information										* Continuation Sheet(s)				
Emission Unit	U	-	0	0	0	0	0	1			Process	P	1	A

Process Description

Process P1A represents natural gas firing in the Siemens SGT6-5000 Class-F combustion turbine, which has a nominal rating of 2,234 mmBtu/hr at -5°F (maximum heat input scenario). Dry low-NOx combustion technology, selective catalytic reduction (SCR) and oxidation catalyst will be used to minimize emissions of NOx, CO, and VOC. The quantity per hour throughput listed below represents the nominal firing rate (2,234 mm Btu/hr at -5°F) and the quantity per year throughput represents the turbine at the firing rate at the annual average ambient temperature of 51 °F (1,998 mmBtu/hr). Natural gas Higher Heating Value (HHV) is assumed to be 1,048 Btu/cubic foot.

Source Classification Code (SCC)	Total Throughput		Throughput Quantity Units	
	Quantity/Hr	Quantity/Yr	Code	Description
2-01-002-01	2.13	1,690.51	0115	million cubic feet of natural gas

Confidential * Operating at Maximum Capacity	Operating Schedule		Building	Floor/Location
	Hours/Day	Days/Year		
	24	365		

Emission Point Identifier(s)					
CT001	DLN01	SCR01	OXY01		

Emission Source/Control Identifier(s)					

Emission Unit	U	-	0	0	0	0	0	1			Process	P	2	A
---------------	---	---	---	---	---	---	---	---	--	--	---------	---	---	---

Process Description

Process P2A represents combined natural gas firing in the Siemens SGT6-5000 Class-F combustion turbine, which has a nominal rating of 2,234 mmBtu/hr at -5°F (maximum heat input scenario) and natural gas firing with in the duct burner, which has a nominal rating of 500 mmBtu/hr. Dry low-NOx combustion technology, selective catalytic reduction (SCR) and oxidation catalyst will be used to minimize emissions of NOx, CO, and VOC. The quantity per hour throughput listed below represents the maximum firing rate of the turbine (2,234 mmBtu/hr at -5°F) plus the duct burner at rated capacity (500 mm Btu/hr) and the quantity per year throughput represents 8,760 hours of natural gas firing in the turbine at the annual average ambient temperature of 51 °F (1,998 mmBtu/hr) plus 2,628 hours of natural gas firing in the duct burner at rated capacity (500 mmBtu/hr). Natural gas Higher Heating Value (HHV) is assumed to be 1,048 Btu/cubic foot.

Source Classification Code (SCC)	Total Throughput		Throughput Quantity Units	
	Quantity/Hr	Quantity/Yr	Code	Description
2-01-002-01	2.61	1,690.51	0115	million cubic feet of natural gas

Confidential * Operating at Maximum Capacity	Operating Schedule		Building	Floor/Location
	Hours/Day	Days/Year		
	24	365		

Emission Point Identifier(s)					
CT001	DB001	DLN01	SCR01	OXY01	

Emission Source/Control Identifier(s)					

**New York State Department of Environmental Conservation
Air Permit Application Form**

Department of Environmental Conservation

DEC ID											
3	-	3	3	5	6	-	0	0	1	3	6

Section IV - Emission Unit Information

Process Information (continuation)												
Emission Unit	U	-	0	0	0	0	1		Process	P	3	A
Description												
<p>Process P3A represents fuel oil firing in the Class-F combustion turbine, which has a nominal rating of 2,145 mm Btu/hr at -5 F (maximum heat input scenario). Dry low-NOx combustion technology, steam or water injection, selective catalytic reduction (SCR) and oxidation catalyst will be used to minimize emissions of NOx, CO, and VOC. The quantity per hour throughput listed below represents the nominal firing rate (2,145 mm Btu/hr at -5 F) and the quantity per year fuel oil firing at the firing rate at -5 F ambient temperature. Fuel oil Higher Heating Value (HHV) is assumed to be 139,728 throughput represents 720 hours of Btu/gallon.</p>												
Source Classification Code (SCC)	Total Throughput		Throughput Quantity Units									
	Quantity/Hr	Quantity/Yr	Code	Description								
2-01-001-01	15.351	10,017	0607	1000 gallons burned								
<input type="checkbox"/> Confidential <input checked="" type="checkbox"/> Operating at Maximum Capacity		Operating Schedule		Building	Floor/Location							
		Hrs/Day	Days/Yr									
		24	30									
Emission Point Identifier(s)												
CT001	DLN01	STI01	SCR01	OXY01								
Emission Source/Control Identifier(s)												
Emission Unit	-						Process					
Description												
Source Classification Code (SCC)	Total Throughput		Throughput Quantity Units									
	Quantity/Hr	Quantity/Yr	Code	Description								
<input type="checkbox"/> Confidential <input type="checkbox"/> Operating at Maximum Capacity		Operating Schedule		Building	Floor/Location							
		Hrs/Day	Days/Yr									
Emission Point Identifier(s)												
Emission Source/Control Identifier(s)												

New York State Department of Environmental Conservation
Air Permit Application



Department of
**Environmental
 Conservation**

DEC ID											
3	-	3	3	5	6	-	0	0	1	3	6

Section IV - Emission Unit Information

Emission Unit Description											Continuation Sheet(s)
Emission Unit	U	-	0	0	0	0	0	2			
<p>One Siemens SGT6-5000 F-Class combustion turbine which has a nominal rating of 1,998 mm Btu/hr at 51 °F (2,234 mmBtu/hr at -5°F) on natural gas and (2,145 mmBtu/hr at -5°F) on fuel oil (<0.0015% sulfur). The turbine is equipped with dry low-NOx combustors, steam injection, SCR and oxidation catalyst emission controls. This emission unit also contains a natural gas-fired duct burner rated at a nominal capacity of 500 mmBtu/hr.</p>											

Building Information				Continuation Sheet(s)	
Building ID	Building Name	Length (ft)	Width (ft)	Orientation	
GEN02	Generation Building	300	260	North	
ACC02	Air Cooled Condenser	296	327	North	
HRSG02	Heat Recovery Steam Generator - Inside Generation Building	160	105	North	

Emission Unit	Emission Unit Emissions Summary				* Continuation Sheet(s)	
U	-	0	0	0	0	2
CAS Number	Contaminant Name					
0NY075-00 - 0	Particulates					
ERP (lbs/yr)	Potential to Emit			Actual Emissions		
	(lbs/hr)	(lbs/yr)		(lbs/hr)	(lbs/yr)	
		94,200.0				
CAS Number	Contaminant Name					
0NY075 - 00 - 5	PM-10					
ERP (lbs/yr)	Potential to Emit			Actual Emissions		
	(lbs/hr)	(lbs/yr)		(lbs/hr)	(lbs/yr)	
		94,200.0				
CAS Number	Contaminant Name					
0NY750 - 02 - 5	PM-2.5					
ERP (lbs/yr)	Potential to Emit			Actual Emissions		
	(lbs/hr)	(lbs/yr)		(lbs/hr)	(lbs/yr)	
		94,200.0				
CAS Number	Contaminant Name					
0NY210 - 00 - 0	Oxides of Nitrogen					
ERP (lbs/yr)	Potential to Emit			Actual Emissions		
	(lbs/hr)	(lbs/yr)		(lbs/hr)	(lbs/yr)	
		174,900.0				

New York State Department of Environmental Conservation
Air Permit Application Form

Department of Environmental Conservation

DEC ID											
3	-	3	3	5	6	-	0	0	1	3	6

Section IV - Emission Unit Information

Emission Unit		Emission Unit Emissions Summary (continuation)			
U - 000002					
CAS No.		Contaminant Name			
000630 - 08 - 0		Carbon Monoxide			
ERP (lbs/yr)	PTE Emissions		Actual Emissions		
	(lbs/hr)	(lbs/yr)	(lbs/hr)	(lbs/yr)	
		334,000.0			
CAS No.		Contaminant Name			
007446 - 09 - 5		Sulfur Dioxide			
ERP (lbs/yr)	PTE Emissions		Actual Emissions		
	(lbs/hr)	(lbs/yr)	(lbs/hr)	(lbs/yr)	
		41,000.0			
CAS No.		Contaminant Name			
0NY998 - 00 - 0		Volatile Organic Compounds			
ERP (lbs/yr)	PTE Emissions		Actual Emissions		
	(lbs/hr)	(lbs/yr)	(lbs/hr)	(lbs/yr)	
		62,800.0			
CAS No.		Contaminant Name			
0NY100 - 00 - 0		Total Hazardous Air Pollutants			
ERP (lbs/yr)	PTE Emissions		Actual Emissions		
	(lbs/hr)	(lbs/yr)	(lbs/hr)	(lbs/yr)	
		13,770.0			
CAS No.		Contaminant Name			
0NY750 - 00 - 0		Carbon Dioxide Equivalents			
ERP (lbs/yr)	PTE Emissions		Actual Emissions		
	(lbs/hr)	(lbs/yr)	(lbs/hr)	(lbs/yr)	
		2,164,438,000.0			
CAS No.		Contaminant Name			
007664-93-9		Sulfuric Acid			
ERP (lbs/yr)	PTE Emissions		Actual Emissions		
	(lbs/hr)	(lbs/yr)	(lbs/hr)	(lbs/yr)	
		12,600.0			
CAS No.		Contaminant Name			
007664-41-7		Ammonia			
ERP (lbs/yr)	PTE Emissions		Actual Emissions		
	(lbs/hr)	(lbs/yr)	(lbs/hr)	(lbs/yr)	
		104,800.0			

New York State Department of Environmental Conservation
Air Permit Application Form

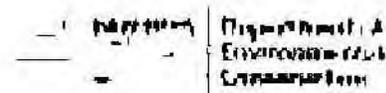

DEC ID											
3	-	3	3	5	6	-	0	0	1	3	6

Section IV - Emission Unit Information

Emission Unit		Emission Unit Emissions Summary (continuation)			
U - 000002					
CAS No.		Contaminant Name			
007439 - 92 - 1		Lead (elemental)			
ERP (lbs/yr)	PTE Emissions		Actual Emissions		
	(lbs/hr)	(lbs/yr)	(lbs/hr)	(lbs/yr)	
		22.30			
CAS No.		Contaminant Name			
ERP (lbs/yr)	PTE Emissions		Actual Emissions		
	(lbs/hr)	(lbs/yr)	(lbs/hr)	(lbs/yr)	
CAS No.		Contaminant Name			
ERP (lbs/yr)	PTE Emissions		Actual Emissions		
	(lbs/hr)	(lbs/yr)	(lbs/hr)	(lbs/yr)	
CAS No.		Contaminant Name			
ERP (lbs/yr)	PTE Emissions		Actual Emissions		
	(lbs/hr)	(lbs/yr)	(lbs/hr)	(lbs/yr)	
CAS No.		Contaminant Name			
ERP (lbs/yr)	PTE Emissions		Actual Emissions		
	(lbs/hr)	(lbs/yr)	(lbs/hr)	(lbs/yr)	
CAS No.		Contaminant Name			
ERP (lbs/yr)	PTE Emissions		Actual Emissions		
	(lbs/hr)	(lbs/yr)	(lbs/hr)	(lbs/yr)	
CAS No.		Contaminant Name			
ERP (lbs/yr)	PTE Emissions		Actual Emissions		
	(lbs/hr)	(lbs/yr)	(lbs/hr)	(lbs/yr)	

**New York State Department of Environmental Conservation
Air Permit Application**



Department of
Environmental
Conservation

DEC ID											
3	-	3	3	5	6	-	0	0	1	3	6

Emission Point Information							Continuation Sheet(s)
Emission Point							E P 0 0 2
Ground Elevation (ft)	Height (ft)	Height Above Structure (ft)	Inside Diameter (in)	Exit Temp. (°F)	Cross Section		
					Length (in)	Width (in)	
496	275	140	228	195			
Exit Velocity (FPS)	Exit Flow (ACFM)	NYTM (E) (KM)	NYTM (N) (KM)	Building	Distance to Property Line (ft)	Date of Removal	
76.91	1,357,528	546.99053	4584.65455		305		
Emission Point							
Ground Elevation (ft)	Height (ft)	Height Above Structure (ft)	Inside Diameter (in)	Exit Temp. (°F)	Cross Section		
					Length (in)	Width (in)	
Exit Velocity (FPS)	Exit Flow (ACFM)	NYTM (E) (KM)	NYTM (N) (KM)	Building	Distance to Property Line (ft)	Date of Removal	
Emission Point							
Ground Elevation (ft)	Height (ft)	Height Above Structure (ft)	Inside Diameter (in)	Exit Temp. (°F)	Cross Section		
					Length (in)	Width (in)	
Exit Velocity (FPS)	Exit Flow (ACFM)	NYTM (E) (KM)	NYTM (N) (KM)	Building	Distance to Property Line (ft)	Date of Removal	

Emission Source/Control Information							* Continuation Sheet(s)	
Emission Source		Date of Construction	Date of Operation	Date of Removal	Control Type		Manufacturer's Name/Model Number	
ID	Type				Code	Description		
C	T 0 0 2	08/2015	01/2018				Siemens SGT6-5000 Class-F Turbine	
Design Capacity	Design Capacity Units			Waste Feed		Waste Type		
	Code	Description		Code	Description	Code	Description	
2234	25	mmBtu/hr						
Emission Source		Date of Construction	Date of Operation	Date of Removal	Control Type		Manufacturer's Name/Model Number	
ID	Type				Code	Description		
D	B 0 0 2	08/2015	01/2018				Fomey Duct Burner	
Design Capacity	Design Capacity Units			Waste Feed		Waste Type		
	Code	Description		Code	Description	Code	Description	
500	25	mmBtu/hr						
Emission Source		Date of Construction	Date of Operation	Date of Removal	Control Type		Manufacturer's Name/Model Number	
ID	Type				Code	Description		
D	L N 0 2	08/2015	01/2018		103	dry low NOx burner		
Design Capacity	Design Capacity Units			Waste Feed		Waste Type		
	Code	Description		Code	Description	Code	Description	

New York State Department of Environmental Conservation
Air Permit Application Form

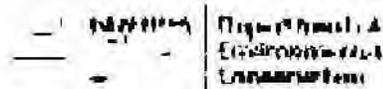

DEC ID											
3	-	3	3	5	6	-	0	0	1	3	6

Section IV - Emission Unit Information

Emission Source/Control (continuation)										
Emission Unit		U - 0 0 0 0 0 2								
Emission Source		Date of Construction	Date of Operation	Date of Removal	Control Type		Manufacturer's Name/Model No.			
ID	Type				Code	Description				
ST102	K	08/2015	01/2018		028	steam or water injection				
Design Capacity	Design Capacity Units				Waste Feed		Waste Type			
	Code	Description			Code	Description	Code	Description		
Emission Source		Date of Construction	Date of Operation	Date of Removal	Control Type		Manufacturer's Name/Model No.			
ID	Type				Code	Description				
SCR02	K	08/2015	01/2018		033	selective catalytic reduction (SCR)	YARA SCR			
Design Capacity	Design Capacity Units				Waste Feed		Waste Type			
	Code	Description			Code	Description	Code	Description		
Emission Source		Date of Construction	Date of Operation	Date of Removal	Control Type		Manufacturer's Name/Model No.			
ID	Type				Code	Description				
OXY02	K	08/2015	01/2018		110	catalytic oxidation	SYNERGY			
Design Capacity	Design Capacity Units				Waste Feed		Waste Type			
	Code	Description			Code	Description	Code	Description		
Emission Source		Date of Construction	Date of Operation	Date of Removal	Control Type		Manufacturer's Name/Model No.			
ID	Type				Code	Description				
Design Capacity	Design Capacity Units				Waste Feed		Waste Type			
	Code	Description			Code	Description	Code	Description		
Emission Source		Date of Construction	Date of Operation	Date of Removal	Control Type		Manufacturer's Name/Model No.			
ID	Type				Code	Description				
Design Capacity	Design Capacity Units				Waste Feed		Waste Type			
	Code	Description			Code	Description	Code	Description		

**New York State Department of Environmental Conservation
Air Permit Application**



Department of Environmental Conservation

DEC ID													
3	-	3	3	5	6	-	0	0	1	3	6		
Process Information										* Continuation Sheet(s)			
Emission Unit U - 0 0 0 0 0 2										Process	P	0	1
Process Description													
<p>Process P01 represents natural gas firing in the Siemens SGT6-5000 Class-F combustion turbine, which has a nominal rating of 2,234 mmBtu/hr at -5°F (maximum heat input scenario). Dry low-NOx combustion technology, selective catalytic reduction (SCR) and oxidation catalyst will be used to minimize emissions of NOx, CO, and VOC. The quantity per hour throughput listed below represents the nominal firing rate (2,234 mm Btu/hr at -5°F) and the quantity per year throughput represents the turbine at the firing rate at the annual average ambient temperature of 51 °F (1,998 mmBtu/hr). Natural gas Higher Heating Value (HHV) is assumed to be 1,048 Btu/cubic foot.</p>													
Source Classification Code (SCC)			Total Throughput				Throughput Quantity Units						
			Quantity/Hr	Quantity/Yr	Code	Description							
2-01-002-01			2	13	1,690	51	0115	million cubic feet of natural gas					
Confidential * Operating at Maximum Capacity			Operating Schedule				Building	Floor/Location					
			Hours/Day		Days/Year								
			24		365								
Emission Point Identifier(s)													
CT002		DLN02		SCR02		OXY02							
Emission Source/Control Identifier(s)													
Emission Unit U - 0 0 0 0 0 2										Process	P	0	2
Process Description													
<p>Process P02 represents combined natural gas firing in the Siemens SGT6-5000 Class-F combustion turbine, which has a nominal rating of 2,234 mmBtu/hr at -5°F (maximum heat input scenario) and natural gas firing with the duct burner, which has a nominal rating of 500 mmBtu/hr. Dry low-NOx combustion technology, selective catalytic reduction (SCR) and oxidation catalyst will be used to minimize emissions of NOx, CO, and VOC. The quantity per hour throughput listed below represents the maximum firing rate of the turbine (2,234 mmBtu/hr at -5°F) plus the duct burner at rated capacity (500 mm Btu/hr) and the quantity per year throughput represents 8,760 hours of natural gas firing in the turbine at the annual average ambient temperature of 51 °F (1,998 mmBtu/hr) plus 2,628 hours of natural gas firing in the duct burner at rated capacity (500 mmBtu/hr). Natural gas Higher Heating Value (HHV) is assumed to be 1,048 Btu/cubic foot.</p>													
Source Classification Code (SCC)			Total Throughput				Throughput Quantity Units						
			Quantity/Hr	Quantity/Yr	Code	Description							
2-01-002-01			2	61	1,690	51	0115	million cubic feet of natural gas					
Confidential * Operating at Maximum Capacity			Operating Schedule				Building	Floor/Location					
			Hours/Day		Days/Year								
			24		365								
Emission Point Identifier(s)													
CT002		DB002		DLN02		SCR02		OXY02					
Emission Source/Control Identifier(s)													

**New York State Department of Environmental Conservation
Air Permit Application Form**

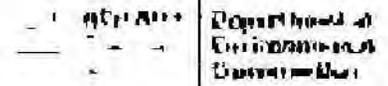

DEC ID											
3	-	3	3	5	6	-	0	0	1	3	6

Section IV - Emission Unit Information

Process Information (continuation)																
Emission Unit	U	-	0	0	0	0	2					Process	P	0	3	
Description																
<p>Process P03 represents fuel oil firing in the Siemens SGT6-5000 Class-F combustion turbine, which has a nominal rating of 2,145 mm Btu/hr at -5 F (maximum heat input scenario). Dry low-NOx combustion technology, steam or water injection, selective catalytic reduction (SCR) and oxidation catalyst will be used to minimize emissions of NOx, CO, and VOC. The quantity per hour throughput listed below represents the nominal firing rate (2,145 mm Btu/hr at -5 F) and the quantity per year fuel oil firing at the firing rate at -5 F ambient temperature. Fuel oil Higher Heating Value (HHV) is assumed to be 139,728 throughput represents 720 hours of Btu/gallon.</p>																
Source Classification Code (SCC)	Total Throughput				Throughput Quantity Units											
	Quantity/Hr	Quantity/Yr	Code	Description												
2-01-001-01	15.351	10,017	0607	1000 gallons burned												
<input type="checkbox"/> Confidential <input checked="" type="checkbox"/> Operating at Maximum Capacity				Operating Schedule				Building	Floor/Location							
				Hrs/Day	Days/Yr											
				24	30											
Emission Point Identifier(s)																
CT002	DLN02	STI02	SCR02	OXY02												
Emission Source/Control Identifier(s)																
Emission Unit	-												Process			
Description																
Source Classification Code (SCC)	Total Throughput				Throughput Quantity Units											
	Quantity/Hr	Quantity/Yr	Code	Description												
								Building	Floor/Location							
				Hrs/Day	Days/Yr											
Emission Point Identifier(s)																
Emission Source/Control Identifier(s)																

**New York State Department of Environmental Conservation
Air Permit Application**



Department of
Environmental
Conservation

DEC ID											
3	-	3	3	5	6	-	0	0	1	3	6

Section IV - Emission Unit Information

Emission Unit Description											Continuation Sheet(s)
Emission Unit	U	-	0	0	0	0	0	3			
<p>One auxiliary boiler with a nominal rating of 48.1 mmBtu/hr that will fire natural gas exclusively. The boiler hours will be limited to 2000 hours per year. The boiler will operate primarily to assist with startups and shutdowns of the turbine.</p>											

Building Information				Continuation Sheet(s)
Building ID	Building Name	Length (ft)	Width (ft)	Orientation
GEN02	Auxiliary Boiler Located Inside Generation Building	300	260	North

Emission Unit	Emission Unit Emissions Summary				* Continuation Sheet(s)	
U	-	0	0	0	0	3
CAS Number		Contaminant Name				
0NY075 - 00 - 0		Particulates				
ERP (lbs/yr)	Potential to Emit		Actual Emissions			
	(lbs/hr)	(lbs/yr)	(lbs/hr)	(lbs/yr)		
		600.0				
CAS Number		Contaminant Name				
0NY075 - 00 - 5		PM-10				
ERP (lbs/yr)	Potential to Emit		Actual Emissions			
	(lbs/hr)	(lbs/yr)	(lbs/hr)	(lbs/yr)		
		600.0				
CAS Number		Contaminant Name				
0NY750 - 02 - 5		PM-2.5				
ERP (lbs/yr)	Potential to Emit		Actual Emissions			
	(lbs/hr)	(lbs/yr)	(lbs/hr)	(lbs/yr)		
		600.0				
CAS Number		Contaminant Name				
0NY210 - 00 - 0		Oxides of Nitrogen				
ERP (lbs/yr)	Potential to Emit		Actual Emissions			
	(lbs/hr)	(lbs/yr)	(lbs/hr)	(lbs/yr)		
		4,320.0				

**New York State Department of Environmental Conservation
Air Permit Application Form**

Department of Environmental Conservation

DEC ID											
3	-	3	3	5	6	-	0	0	1	3	6

Section IV - Emission Unit Information

Emission Unit		Emission Unit Emissions Summary (continuation)			
U - 0 0 0 0 3					
CAS No.		Contaminant Name			
000630 - 08 - 0		Carbon Monoxide			
ERP (lbs/yr)	PTE Emissions		Actual Emissions		
	(lbs/hr)	(lbs/yr)	(lbs/hr)	(lbs/yr)	
		6,940.0			
CAS No.		Contaminant Name			
007446 - 09 - 5		Sulfur Dioxide			
ERP (lbs/yr)	PTE Emissions		Actual Emissions		
	(lbs/hr)	(lbs/yr)	(lbs/hr)	(lbs/yr)	
		220.0			
CAS No.		Contaminant Name			
0NY998 - 00 - 0		Volatile Organic Compounds			
ERP (lbs/yr)	PTE Emissions		Actual Emissions		
	(lbs/hr)	(lbs/yr)	(lbs/hr)	(lbs/yr)	
		360.0			
CAS No.		Contaminant Name			
007664-93-9		Sulfuric Acid			
ERP (lbs/yr)	PTE Emissions		Actual Emissions		
	(lbs/hr)	(lbs/yr)	(lbs/hr)	(lbs/yr)	
		220.0			
CAS No.		Contaminant Name			
ERP (lbs/yr)	PTE Emissions		Actual Emissions		
	(lbs/hr)	(lbs/yr)	(lbs/hr)	(lbs/yr)	
CAS No.		Contaminant Name			
ERP (lbs/yr)	PTE Emissions		Actual Emissions		
	(lbs/hr)	(lbs/yr)	(lbs/hr)	(lbs/yr)	
CAS No.		Contaminant Name			
ERP (lbs/yr)	PTE Emissions		Actual Emissions		
	(lbs/hr)	(lbs/yr)	(lbs/hr)	(lbs/yr)	

**New York State Department of Environmental Conservation
Air Permit Application**



Department of
Environmental
Conservation

DEC ID											
3	-	3	3	5	6	-	0	0	1	3	6

Emission Point Information							Continuation Sheet(s)
Emission Point		E	P	0	0	3	
Ground Elevation (ft)	Height (ft)	Height Above Structure (ft)	Inside Diameter (in)	Exit Temp. (°F)	Cross Section		
					Length (in)	Width (in)	
496	275	140	228	301			
Exit Velocity (FPS)	Exit Flow (ACFM)	NYTM (E) (KM)	NYTM (N) (KM)	Building	Distance to Property Line (ft)	Date of Removal	
57.53	14,194	546.99053	4584.65455		305		
Emission Point							
Ground Elevation (ft)	Height (ft)	Height Above Structure (ft)	Inside Diameter (in)	Exit Temp. (°F)	Cross Section		
					Length (in)	Width (in)	
Exit Velocity (FPS)	Exit Flow (ACFM)	NYTM (E) (KM)	NYTM (N) (KM)	Building	Distance to Property Line (ft)	Date of Removal	
Emission Point							
Ground Elevation (ft)	Height (ft)	Height Above Structure (ft)	Inside Diameter (in)	Exit Temp. (°F)	Cross Section		
					Length (in)	Width (in)	
Exit Velocity (FPS)	Exit Flow (ACFM)	NYTM (E) (KM)	NYTM (N) (KM)	Building	Distance to Property Line (ft)	Date of Removal	

Emission Source/Control Information							Continuation Sheet(s)				
Emission Source		Date of Construction	Date of Operation	Date of Removal	Control Type		Manufacturer's Name/Model Number				
ID	Type				Code	Description					
A	U	X	0	1	C	08/2015	01/2018			low NOx burner	
Design Capacity	Design Capacity Units			Waste Feed		Waste Type					
	Code	Description	Code	Description	Code	Description					
48.1	25	mmBtu/hr									
Emission Source		Date of Construction	Date of Operation	Date of Removal	Control Type		Manufacturer's Name/Model Number				
ID	Type				Code	Description					
L	N	B	0	1	K	08/2015	01/2018			low NOx burner	
Design Capacity	Design Capacity Units			Waste Feed		Waste Type					
	Code	Description	Code	Description	Code	Description					
Emission Source		Date of Construction	Date of Operation	Date of Removal	Control Type		Manufacturer's Name/Model Number				
ID	Type				Code	Description					
F	G	R	0	1	K	08/2015	01/2018			flue gas recirculation	
Design Capacity	Design Capacity Units			Waste Feed		Waste Type					
	Code	Description	Code	Description	Code	Description					

**New York State Department of Environmental Conservation
Air Permit Application**



Department of Environmental Conservation

DEC ID											
3	-	3	3	5	6	-	0	0	1	3	6

Process Information										Continuation Sheet(s)				
Emission Unit	U	-	0	0	0	0	0	3			Process	P	3	B

Process Description

Process P3B represents natural gas firing in the auxiliary boiler, which has a nominal rating of 48.1 mmBtu/hr. Total natural gas usage will not exceed 2,000 full load boiler hours per year. Natural gas Higher Heating Value (HHV) is assumed to be 1,048 Btu/cubic foot.

Source Classification Code (SCC)	Total Throughput		Throughput Quantity Units	
	Quantity/Hr	Quantity/Yr	Code	Description
1-02-006-02	0.07	93.73	0115	million cubic feet of natural gas

Confidential * Operating at Maximum Capacity	Operating Schedule		Building	Floor/Location
	Hours/Day	Days/Year		
	24	365		

Emission Point Identifier(s)						
AUX01	LNB01	FGR01				

Emission Source/Control Identifier(s)						

Emission Unit	-									Process			
---------------	---	--	--	--	--	--	--	--	--	---------	--	--	--

Process Description

Source Classification Code (SCC)	Total Throughput		Throughput Quantity Units	
	Quantity/Hr	Quantity/Yr	Code	Description

Confidential Operating at Maximum Capacity	Operating Schedule		Building	Floor/Location
	Hours/Day	Days/Year		

Emission Point Identifier(s)						

Emission Source/Control Identifier(s)						

**New York State Department of Environmental Conservation
Air Permit Application**



Department of
Environmental
Conservation

DEC ID											
3	-	3	3	5	6	-	0	0	1	3	6

Section IV - Emission Unit Information

Emission Unit Description											Continuation Sheet(s)
Emission Unit	U	-	0	0	0	0	0	4			
Kohler Power System Model: 1000REOZDE Engine Manufacturer: Detroit Diesel/MTU Engine Model: 16V2000 G85 R163-8A37 Engine: type 4-Cycle, Turbocharged, Intercooled											

Building Information				Continuation Sheet(s)
Building ID	Building Name	Length (ft)	Width (ft)	Orientation
DGB01	Generation Building	32	11	

Emission Unit	Emission Unit Emissions Summary				* Continuation Sheet(s)
U	-	0	0	0	4
CAS Number	Contaminant Name				
0NY075 - 00 - 0	Particulates				
ERP (lbs/yr)	Potential to Emit		Actual Emissions		
	(lbs/hr)	(lbs/yr)	(lbs/hr)	(lbs/yr)	
		98.0			
CAS Number	Contaminant Name				
0NY075 - 00 - 5	PM-2.5				
ERP (lbs/yr)	Potential to Emit		Actual Emissions		
	(lbs/hr)	(lbs/yr)	(lbs/hr)	(lbs/yr)	
		98.0			
CAS Number	Contaminant Name				
0NY750 - 02 - 5	PM-2.5				
ERP (lbs/yr)	Potential to Emit		Actual Emissions		
	(lbs/hr)	(lbs/yr)	(lbs/hr)	(lbs/yr)	
		98.0			
CAS Number	Contaminant Name				
0NY210 - 00 - 0	Oxides of Nitrogen				
ERP (lbs/yr)	Potential to Emit		Actual Emissions		
	(lbs/hr)	(lbs/yr)	(lbs/hr)	(lbs/yr)	
		6,660			

**New York State Department of Environmental Conservation
Air Permit Application Form**

Department of Environmental Conservation

DEC ID											
3	-	3	3	5	6	-	0	0	1	3	6

Section IV - Emission Unit Information

Emission Unit		Emission Unit Emissions Summary (continuation)			
0000004					
CAS No.		Contaminant Name			
000630 - 08 - 0		Carbon Monoxide			
ERP (lbs/yr)	PTE Emissions		Actual Emissions		
	(lbs/hr)	(lbs/yr)	(lbs/hr)	(lbs/yr)	
		984.0			
CAS No.		Contaminant Name			
007446 - 09 - 5		Sulfur Dioxide			
ERP (lbs/yr)	PTE Emissions		Actual Emissions		
	(lbs/hr)	(lbs/yr)	(lbs/hr)	(lbs/yr)	
		9.7			
CAS No.		Contaminant Name			
0NY998 - 00 - 0		Volatile Organic Compounds			
ERP (lbs/yr)	PTE Emissions		Actual Emissions		
	(lbs/hr)	(lbs/yr)	(lbs/hr)	(lbs/yr)	
		282.0			
CAS No.		Contaminant Name			
007664-93-9		Sulfuric Acid			
ERP (lbs/yr)	PTE Emissions		Actual Emissions		
	(lbs/hr)	(lbs/yr)	(lbs/hr)	(lbs/yr)	
		0.2			
CAS No.		Contaminant Name			
ERP (lbs/yr)	PTE Emissions		Actual Emissions		
	(lbs/hr)	(lbs/yr)	(lbs/hr)	(lbs/yr)	
CAS No.		Contaminant Name			
ERP (lbs/yr)	PTE Emissions		Actual Emissions		
	(lbs/hr)	(lbs/yr)	(lbs/hr)	(lbs/yr)	
CAS No.		Contaminant Name			
ERP (lbs/yr)	PTE Emissions		Actual Emissions		
	(lbs/hr)	(lbs/yr)	(lbs/hr)	(lbs/yr)	

**New York State Department of Environmental Conservation
Air Permit Application**



Department of
Environmental
Conservation

DEC ID											
3	-	3	3	5	6	-	0	0	1	3	6

Emission Point Information							Continuation Sheet(s)
Emission Point		E	P	0	0	4	
Ground Elevation (ft)	Height (ft)	Height Above Structure (ft)	Inside Diameter (in)	Exit Temp. (°F)	Cross Section		
					Length (in)	Width (in)	
464	50	27	18	1,022			
Exit Velocity (FPS)	Exit Flow (ACFM)	NYTM (E) (KM)	NYTM (N) (KM)	Building	Distance to Property Line (ft)	Date of Removal	
104.3	7,840	547.12988	4584.6514	DGB01	262		
Emission Point							
Ground Elevation (ft)	Height (ft)	Height Above Structure (ft)	Inside Diameter (in)	Exit Temp. (°F)	Cross Section		
					Length (in)	Width (in)	
Exit Velocity (FPS)	Exit Flow (ACFM)	NYTM (E) (KM)	NYTM (N) (KM)	Building	Distance to Property Line (ft)	Date of Removal	
Emission Point							
Ground Elevation (ft)	Height (ft)	Height Above Structure (ft)	Inside Diameter (in)	Exit Temp. (°F)	Cross Section		
					Length (in)	Width (in)	
Exit Velocity (FPS)	Exit Flow (ACFM)	NYTM (E) (KM)	NYTM (N) (KM)	Building	Distance to Property Line (ft)	Date of Removal	

Emission Source/Control Information							Continuation Sheet(s)			
Emission Source		Date of Construction	Date of Operation	Date of Removal	Control Type		Manufacturer's Name/Model Number			
ID	Type				Code	Description				
B	G	0	1		C	08/2015	01/2018			16V2000 G85 R163-8A37
Design Capacity	Design Capacity Units			Waste Feed		Waste Type				
	Code	Description		Code	Description	Code	Description			
10.08	0104	mmBtu/hr								
Emission Source		Date of Construction	Date of Operation	Date of Removal	Control Type		Manufacturer's Name/Model Number			
ID	Type				Code	Description				
Design Capacity	Design Capacity Units			Waste Feed		Waste Type				
	Code	Description		Code	Description	Code	Description			
Emission Source		Date of Construction	Date of Operation	Date of Removal	Control Type		Manufacturer's Name/Model Number			
ID	Type				Code	Description				
Design Capacity	Design Capacity Units			Waste Feed		Waste Type				
	Code	Description		Code	Description	Code	Description			

**New York State Department of Environmental Conservation
Air Permit Application**



Department of
Environmental
Conservation

DEC ID											
3	-	3	3	5	6	-	0	0	1	3	6

Section IV - Emission Unit Information

Emission Unit Description											Continuation Sheet(s)	
Emission Unit	U	-	0	0	0	0	0	5				
Fire Pump Diesel Engine Cummins CFP9E-F20												

Building Information					* Continuation Sheet(s)	
Building ID	Building Name			Length (ft)	Width (ft)	Orientation
FPB01	Fire Water Pump Building			30	12	

Emission Unit		Emission Unit Emissions Summary				Continuation Sheet(s)
U	-	0	0	0	0	5
CAS Number		Contaminant Name				
0NY075 - 00 - 0		Particulates				
ERP (lbs/yr)	Potential to Emit		Actual Emissions			
	(lbs/hr)	(lbs/yr)	(lbs/hr)	(lbs/yr)		
		36.0				
CAS Number		Contaminant Name				
0NY075 - 00 - 5		PM-10				
ERP (lbs/yr)	Potential to Emit		Actual Emissions			
	(lbs/hr)	(lbs/yr)	(lbs/hr)	(lbs/yr)		
		36.0				
CAS Number		Contaminant Name				
0NY750 - 02 - 5		PM-2.5				
ERP (lbs/yr)	Potential to Emit		Actual Emissions			
	(lbs/hr)	(lbs/yr)	(lbs/hr)	(lbs/yr)		
		36.0				
CAS Number		Contaminant Name				
0NY210 - 00 - 0		Oxides of Nitrogen				
ERP (lbs/yr)	Potential to Emit		Actual Emissions			
	(lbs/hr)	(lbs/yr)	(lbs/hr)	(lbs/yr)		
		684.0				

**New York State Department of Environmental Conservation
Air Permit Application Form**

Department of Environmental Conservation

DEC ID											
3	-	3	3	5	6	-	0	0	1	3	6

Section IV - Emission Unit Information

Emission Unit		Emission Unit Emissions Summary (continuation)			
U - 000005					
CAS No.		Contaminant Name			
000630 - 08 - 0		Carbon Monoxide			
ERP (lbs/yr)	PTE Emissions		Actual Emissions		
	(lbs/hr)	(lbs/yr)	(lbs/hr)	(lbs/yr)	
		440.0			
CAS No.		Contaminant Name			
007446 - 09 - 5		Sulfur Dioxide			
ERP (lbs/yr)	PTE Emissions		Actual Emissions		
	(lbs/hr)	(lbs/yr)	(lbs/hr)	(lbs/yr)	
		150.2			
CAS No.		Contaminant Name			
0NY998 - 00 - 0		Volatile Organic Compounds			
ERP (lbs/yr)	PTE Emissions		Actual Emissions		
	(lbs/hr)	(lbs/yr)	(lbs/hr)	(lbs/yr)	
		38.0			
CAS No.		Contaminant Name			
007664-93-9		Sulfuric Acid			
ERP (lbs/yr)	PTE Emissions		Actual Emissions		
	(lbs/hr)	(lbs/yr)	(lbs/hr)	(lbs/yr)	
		0.030			
CAS No.		Contaminant Name			
ERP (lbs/yr)	PTE Emissions		Actual Emissions		
	(lbs/hr)	(lbs/yr)	(lbs/hr)	(lbs/yr)	
CAS No.		Contaminant Name			
ERP (lbs/yr)	PTE Emissions		Actual Emissions		
	(lbs/hr)	(lbs/yr)	(lbs/hr)	(lbs/yr)	
CAS No.		Contaminant Name			
ERP (lbs/yr)	PTE Emissions		Actual Emissions		
	(lbs/hr)	(lbs/yr)	(lbs/hr)	(lbs/yr)	

**New York State Department of Environmental Conservation
Air Permit Application**



Department of
Environmental
Conservation

DEC ID											
3	-	3	3	5	6	-	0	0	1	3	6

Emission Point Information							Continuation Sheet(s)
Emission Point		E	P	0	0	5	
Ground Elevation (ft)	Height (ft)	Height Above Structure (ft)	Inside Diameter (in)	Exit Temp. (°F)	Cross Section		
					Length (in)	Width (in)	
464	50	37	6	1,030			
Exit Velocity (FPS)	Exit Flow (ACFM)	NYTM (E) (KM)	NYTM (N) (KM)	Building	Distance to Property Line (ft)	Date of Removal	
136.2	1,813	546.81502	4584.66944	FPB01	161		
Emission Point							
Ground Elevation (ft)	Height (ft)	Height Above Structure (ft)	Inside Diameter (in)	Exit Temp. (°F)	Cross Section		
					Length (in)	Width (in)	
Exit Velocity (FPS)	Exit Flow (ACFM)	NYTM (E) (KM)	NYTM (N) (KM)	Building	Distance to Property Line (ft)	Date of Removal	
Emission Point							
Ground Elevation (ft)	Height (ft)	Height Above Structure (ft)	Inside Diameter (in)	Exit Temp. (°F)	Cross Section		
					Length (in)	Width (in)	
Exit Velocity (FPS)	Exit Flow (ACFM)	NYTM (E) (KM)	NYTM (N) (KM)	Building	Distance to Property Line (ft)	Date of Removal	

Emission Source/Control Information							Continuation Sheet(s)				
Emission Source		Date of Construction	Date of Operation	Date of Removal	Control Type		Manufacturer's Name/Model Number				
ID	Type				Code	Description					
F	P	0	1		C	08/2015	01/2018				CFP9E-F20
Design Capacity	Design Capacity Units			Waste Feed		Waste Type					
	Code	Description		Code	Description	Code	Description				
1.96	0104	mmBtu/hr									
Emission Source		Date of Construction	Date of Operation	Date of Removal	Control Type		Manufacturer's Name/Model Number				
ID	Type				Code	Description					
Design Capacity	Design Capacity Units			Waste Feed		Waste Type					
	Code	Description		Code	Description	Code	Description				
Emission Source		Date of Construction	Date of Operation	Date of Removal	Control Type		Manufacturer's Name/Model Number				
ID	Type				Code	Description					
Design Capacity	Design Capacity Units			Waste Feed		Waste Type					
	Code	Description		Code	Description	Code	Description				

**New York State Department of Environmental Conservation
Air Permit Application**



Department of
Environmental
Conservation

DEC ID											
3	-	3	3	5	6	-	0	0	1	3	6

Section IV - Emission Unit Information

Emission Unit Description											Continuation Sheet(s)
Emission Unit	U	-	0	0	0	0	0	6			
One Dew Point Heater with Two Fuel Gas Burners: Model: Maxon OVENPAK® LE 45 Gas Burners – with SMARTLINK® DS Actuator											

Building Information				* Continuation Sheet(s)	
Building ID	Building Name	Length (ft)	Width (ft)	Orientation	
None	Located Outdoor				

Emission Unit		Emission Unit Emissions Summary				Continuation Sheet(s)
U	-	0	0	0	0	6
CAS Number		Contaminant Name				
0NY075 - 00 - 0		Particulates				
ERP (lbs/yr)	Potential to Emit		Actual Emissions			
	(lbs/hr)	(lbs/yr)	(lbs/hr)	(lbs/yr)		
		666.0				
CAS Number		Contaminant Name				
0NY075 - 00 - 5		PM-10				
ERP (lbs/yr)	Potential to Emit		Actual Emissions			
	(lbs/hr)	(lbs/yr)	(lbs/hr)	(lbs/yr)		
		666.0				
CAS Number		Contaminant Name				
0NY750 - 02 - 5		PM-2.5				
ERP (lbs/yr)	Potential to Emit		Actual Emissions			
	(lbs/hr)	(lbs/yr)	(lbs/hr)	(lbs/yr)		
		666.0				
CAS Number		Contaminant Name				
0NY210 - 00 - 0		Oxides of Nitrogen				
ERP (lbs/yr)	Potential to Emit		Actual Emissions			
	(lbs/hr)	(lbs/yr)	(lbs/hr)	(lbs/yr)		
		3,190.0				

**New York State Department of Environmental Conservation
Air Permit Application Form**

Department of Environmental Conservation

DEC ID											
3	-	3	3	5	6	-	0	0	1	3	6

Section IV - Emission Unit Information

Emission Unit		Emission Unit Emissions Summary (continuation)			
U - 0 0 0 0 0 6					
CAS No.		Contaminant Name			
000630 - 08 - 0		Carbon Monoxide			
ERP (lbs/yr)	PTE Emissions		Actual Emissions		
	(lbs/hr)	(lbs/yr)	(lbs/hr)	(lbs/yr)	
		6,394.0			
CAS No.		Contaminant Name			
007446 - 09 - 5		Sulfur Dioxide			
ERP (lbs/yr)	PTE Emissions		Actual Emissions		
	(lbs/hr)	(lbs/yr)	(lbs/hr)	(lbs/yr)	
		192.0			
CAS No.		Contaminant Name			
0NY998 - 00 - 0		Volatile Organic Compounds			
ERP (lbs/yr)	PTE Emissions		Actual Emissions		
	(lbs/hr)	(lbs/yr)	(lbs/hr)	(lbs/yr)	
		438.0			
CAS No.		Contaminant Name			
007664-93-9		Sulfuric Acid			
ERP (lbs/yr)	PTE Emissions		Actual Emissions		
	(lbs/hr)	(lbs/yr)	(lbs/hr)	(lbs/yr)	
		17.6			
CAS No.		Contaminant Name			
ERP (lbs/yr)	PTE Emissions		Actual Emissions		
	(lbs/hr)	(lbs/yr)	(lbs/hr)	(lbs/yr)	
CAS No.		Contaminant Name			
ERP (lbs/yr)	PTE Emissions		Actual Emissions		
	(lbs/hr)	(lbs/yr)	(lbs/hr)	(lbs/yr)	
CAS No.		Contaminant Name			
ERP (lbs/yr)	PTE Emissions		Actual Emissions		
	(lbs/hr)	(lbs/yr)	(lbs/hr)	(lbs/yr)	

**New York State Department of Environmental Conservation
Air Permit Application**



Department of
Environmental
Conservation

DEC ID											
3	-	3	3	5	6	-	0	0	1	3	6

Emission Point Information							Continuation Sheet(s)
Emission Point							E P 0 0 6
Ground Elevation (ft)	Height (ft)	Height Above Structure (ft)	Inside Diameter (in)	Exit Temp. (°F)	Cross Section		
					Length (in)	Width (in)	
464	125		24	850			
Exit Velocity (FPS)	Exit Flow (ACFM)	NYTM (E) (KM)	NYTM (N) (KM)	Building	Distance to Property Line (ft)	Date of Removal	
16.07	3,031	546.95885	4584.58	Outdoors	156		
Emission Point							
Ground Elevation (ft)	Height (ft)	Height Above Structure (ft)	Inside Diameter (in)	Exit Temp. (°F)	Cross Section		
					Length (in)	Width (in)	
Exit Velocity (FPS)	Exit Flow (ACFM)	NYTM (E) (KM)	NYTM (N) (KM)	Building	Distance to Property Line (ft)	Date of Removal	
Emission Point							
Ground Elevation (ft)	Height (ft)	Height Above Structure (ft)	Inside Diameter (in)	Exit Temp. (°F)	Cross Section		
					Length (in)	Width (in)	
Exit Velocity (FPS)	Exit Flow (ACFM)	NYTM (E) (KM)	NYTM (N) (KM)	Building	Distance to Property Line (ft)	Date of Removal	

Emission Source/Control Information							Continuation Sheet(s)
Emission Source		Date of Construction	Date of Operation	Date of Removal	Control Type		Manufacturer's Name/Model Number
ID	Type				Code	Description	
F G H 1	C	08/2015	01/2018		102	Low NOx Burner	
Design Capacity	Design Capacity Units			Waste Feed		Waste Type	
	Code	Description		Code	Description	Code	Description
9.0	0104	mmBtu/hr					
Emission Source		Date of Construction	Date of Operation	Date of Removal	Control Type		Manufacturer's Name/Model Number
ID	Type				Code	Description	
						Low NOx Burner	
Design Capacity	Design Capacity Units			Waste Feed		Waste Type	
	Code	Description		Code	Description	Code	Description
Emission Source		Date of Construction	Date of Operation	Date of Removal	Control Type		Manufacturer's Name/Model Number
ID	Type				Code	Description	
Design Capacity	Design Capacity Units			Waste Feed		Waste Type	
	Code	Description		Code	Description	Code	Description

New York State Department of Environmental Conservation
Air Permit Application



Department of
Environmental
Conservation

DEC ID											
3	-	3	3	5	6	-	0	0	1	3	6

Emission Unit	Emission Point	Process	Emission Source	Emission Unit Applicable Federal Requirements							* Continuation Sheet(s)		
				Title	Type	Part	Subpart	Section	Subdiv.	Parag.	Subparag.	Cl.	Subcl.
U-00001				40	CFR	60	A	3					
U-00001				40	CFR	60	A	7					
U-00001				40	CFR	60	A	8					
U-00001				40	CFR	60	A	11					

Emission Unit	Emission Point	Process	Emission Source	Emission Unit State Only Requirements							* Continuation Sheet(s)		
				Title	Type	Part	Subpart	Section	Subdiv.	Parag.	Subparag.	Cl.	Subcl.
U-00001				6	NYCRR	204	1	6,7					
U-00001				6	NYCRR	204	2						
U-00001				6	NYCRR	204	3						
U-00001				6	NYCRR	204	4						

Emission Unit Compliance Certification

Continuation Sheet(s)

Rule Citation

Title	Type	Part	Subpart	Section	Subdivision	Paragraph	Subparagraph	Clause	Subclause
6	NYCRR	231	5	4					

* Applicable Federal Requirement

State Only Requirement

Capping

Emission Unit	Emission Point	Process	Emission Source	CAS Number	Contaminant Name
U-00001	EP001	P1A,P2A		NY210-00-0	Oxides of nitrogen

Monitoring Information

* Continuous Emission Monitoring	Monitoring of a Process or Control Device Parameters as a Surrogate
Intermittent Emission Testing	Work Practice Involving Specific Operations
Ambient Air Monitoring	Record Keeping/Maintenance Procedures

Compliance Activity Description

2.0 ppmvd (corrected to 15% O₂) NO_x emission limit for the combustion turbine (with and without the duct burner) based upon the Higher Heating Value (HHV) of the fuel. This emission limit applies at all loads except during startup, shutdown and fuel switching. The facility will use GEMS to monitor NO_x stack emissions. The emission limits represents LAER.

Work Practice Type Code	Process Material		Reference Test Method		
	Code	Description			
			40 CFR Part 60, Appendix A, Method 7E		
Monitored Parameter			Manufacturer's Name/Model Number		
Code	Description				
23	Concentration				
Limit		Limit Units			
Upper	Lower	Code	Description		
2.0		275	parts per million by volume (dry, corrected to 15% O ₂)		
Averaging Method		Monitoring Frequency		Reporting Requirements	
Code	Description	Code	Description	Code	Description
47	3-hour block average	01	Continuous	07	Quarterly

New York State Department of Environmental Conservation
Air Permit Application Form

NY State Department of Environmental Conservation

DEC ID											
3	-	3	3	5	6	-	0	0	1	3	6

Section IV - Emission Unit Information

Emission Unit	Emission Point	Process	Emission Source	Emission Unit Applicable Federal Requirements (continuation)										
				Title	Type	Part	Subpart	Section	Subdiv.	Parag.	Subparag.	Clause	Subcl.	
U-00001				40	CFR	60	A	12						
U-00001				40	CFR	60	A	13						
U-00001				40	CFR	60	A	19						
U-00001				40	CFR	82	F							
U-00001				40	CFR	72	A	6						
U-00001				40	CFR	72	A	9						
U-00001				40	CFR	60	KKKK	4320	a,b					
U-00001				40	CFR	60	KKKK	4325						
U-00001				40	CFR	60	KKKK	4330	a	1,2				
U-00001				40	CFR	60	KKKK	4333	a,b	1,2				
U-00001				40	CFR	60	KKKK	4335	b	1,2,3				
U-00001				40	CFR	60	KKKK	4350						
U-00001				40	CFR	60	KKKK	4365	a					
U-00001				40	CFR	60	KKKK	4375	a					
U-00001				40	CFR	60	KKKK	4380	b					
U-00001				40	CFR	60	KKKK	4395						
U-00001				40	CFR	60	KKKK	4400						
U-00001				40	CFR	60	KKKK	4405						
U-00001				40	CFR	60	KKKK	4345	a,b,c,d,e					
U-00001				40	CFR	75	B	10						
U-00001				40	CFR	75	B	11	d					
U-00001				40	CFR	75	B	11	d	2				
U-00001				40	CFR	75	B	12	c					
U-00001				40	CFR	75	B	13	b					
U-00001				40	CFR	75	C							
U-00001				40	CFR	75	D							
U-00001				40	CFR	75	F	59						
U-00001				40	CFR	75	F	53	a,b,e,f					
U-00001				40	CFR	75	F	54						
U-00001				40	CFR	75	F	58	b	2,3				
U-00001				40	CFR	75	G							

Continuation Sheet 1 of 1

New York State Department of Environmental Conservation
Air Permit Application Form

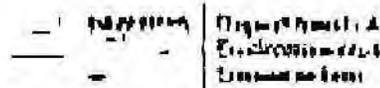

DEC ID											
3	-	3	3	5	6	-	0	0	1	3	6

Section IV - Emission Unit Information

Emission Unit	Emission Point	Process	Emission Source	Emission Unit State Only Requirements (continuation)										
				Title	Type	Part	Subpart	Section	Subdiv.	Parag.	Subparag.	Clause	Subcl.	
U-00001				6	NYCRR	204	5							
U-00001				6	NYCRR	204	6							
U-00001				6	NYCRR	204	7							
U-00001				6	NYCRR	204	8							
U-00001				6	NYCRR	204	9							
U-00001				6	NYCRR	237	1	4	a					
U-00001				6	NYCRR	237	1	6,7						
U-00001				6	NYCRR	237	2							
U-00001				6	NYCRR	237	3							
U-00001				6	NYCRR	237	4	1						
U-00001				6	NYCRR	237	5	3	a					
U-00001				6	NYCRR	237	6							
U-00001				6	NYCRR	237	7							
U-00001				6	NYCRR	237	8							
U-00001				6	NYCRR	238	1	4,6,7						
U-00001				6	NYCRR	238	2							
U-00001				6	NYCRR	238	3							
U-00001				6	NYCRR	238	4	1						
U-00001				6	NYCRR	238	5	3						
U-00001				6	NYCRR	238	6							
U-00001				6	NYCRR	238	7							
U-00001				6	NYCRR	238	8							
U-00001				6	NYCRR	242	1	6,7						
U-00001				6	NYCRR	242	2,3,4,5							
U-00001				6	NYCRR	242	6,7,8,10							
U-00001				6	NYCRR	227	1	2	a	1				
U-00001				6	NYCRR	227	1	3						
U-00001				6	NYCRR	227	1	4	d					
U-00001				6	NYCRR	227	2	4	e	2				
U-00001				6	NYCRR	227	2	6						

New York State Department of Environmental Conservation
Air Permit Application



Department of
Environmental
Conservation

DEC ID													
3 - 3 3 5 6 - 0 0 1 3 6													
Emission Unit	Emission Point	Process	Emission Source	Emission Unit Applicable Federal Requirements							* Continuation Sheet(s)		
				Title	Type	Part	Subpart	Section	Subdiv.	Parag.	Subparag.	Cl.	Subcl.
U-00002				40	CFR	60	A	3					
U-00002				40	CFR	60	A	7					
U-00002				40	CFR	60	A	8					
U-00002				40	CFR	60	A	11					
Emission Unit	Emission Point	Process	Emission Source	Emission Unit State Only Requirements							* Continuation Sheet(s)		
				Title	Type	Part	Subpart	Section	Subdiv.	Parag.	Subparag.	Cl.	Subcl.
U-00002				6	NYCRR	204	1	6,7					
U-00002				6	NYCRR	204	2						
U-00002				6	NYCRR	204	3						
U-00002				6	NYCRR	204	4						
Emission Unit Compliance Certification											Continuation Sheet(s)		
Rule Citation													
Title	Type	Part	Subpart	Section	Subdivision	Paragraph	Subparagraph	Clause	Subclause				
6	NYCRR	231	5	4									
* Applicable Federal Requirement				State Only Requirement				Capping					
Emission Unit	Emission Point	Process	Emission Source	CAS Number			Contaminant Name						
U-00002	EP002	P01,P02		NY210-00-0			Oxides of nitrogen						
Monitoring Information													
* Continuous Emission Monitoring				Monitoring of a Process or Control Device Parameters as a Surrogate									
Intermittent Emission Testing				Work Practice Involving Specific Operations									
Ambient Air Monitoring				Record Keeping/Maintenance Procedures									
Compliance Activity Description													
2.0 ppmvd (corrected to 15% O ₂) NO _x emission limit for the combustion turbine (with and without the duct burner) based upon the Higher Heating Value (HHV) of the fuel. This emission limit applies at all loads except during startup, shutdown and fuel switching. The facility will use GEMS to monitor NO _x stack emissions. The emission limits represents LAER.													
Work Practice Type Code	Process Material			Reference Test Method									
	Code	Description		40 CFR Part 60, Appendix A, Method 7E									
Monitored Parameter			Manufacturer's Name/Model Number										
Code	Description												
23	Concentration												
Limit			Limit Units										
Upper	Lower	Code	Description										
2.0		275	parts per million by volume (dry, corrected to 15% O ₂)										
Averaging Method			Monitoring Frequency				Reporting Requirements						
Code	Description		Code	Description			Code	Description					
47	3-hour block average		01	Continuous			07	Quarterly					

New York State Department of Environmental Conservation
Air Permit Application Form

NY State Air Permit Application Form
Department of Environmental Conservation

DEC ID											
3	-	3	3	5	6	-	0	0	1	3	6

Section IV - Emission Unit Information

Emission Unit	Emission Point	Process	Emission Source	Emission Unit Applicable Federal Requirements (continuation)										
				Title	Type	Part	Subpart	Section	Subdiv.	Parag.	Subparag.	Clause	Subcl.	
U-00002				40	CFR	60	A	12						
U-00002				40	CFR	60	A	13						
U-00002				40	CFR	60	A	19						
U-00002				40	CFR	82	F							
U-00002				40	CFR	72	A	6	a	3				
U-00002				40	CFR	72	A	9						
U-00002				40	CFR	60	KKKK	4320	a,b					
U-00002				40	CFR	60	KKKK	4325						
U-00002				40	CFR	60	KKKK	4330	a	1,2				
U-00002				40	CFR	60	KKKK	4333	a,b	1,2				
U-00002				40	CFR	60	KKKK	4335	b	1,2,3				
U-00002				40	CFR	60	KKKK	4350						
U-00002				40	CFR	60	KKKK	4365	a					
U-00002				40	CFR	60	KKKK	4375	a					
U-00002				40	CFR	60	KKKK	4380	b					
U-00002				40	CFR	60	KKKK	4395						
U-00002				40	CFR	60	KKKK	4400						
U-00002				40	CFR	60	KKKK	4405						
U-00002				40	CFR	60	KKKK	4345	a,b,c,d,e					
U-00002				40	CFR	75	B	10						
U-00002				40	CFR	75	B	11	d					
U-00002				40	CFR	75	B	11	d	2				
U-00002				40	CFR	75	B	12	c					
U-00002				40	CFR	75	B	13	b					
U-00002				40	CFR	75	C							
U-00002				40	CFR	75	D							
U-00002				40	CFR	75	F	59						
U-00002				40	CFR	75	F	53	a,b,e,f					
U-00002				40	CFR	75	F	54						
U-00002				40	CFR	75	F	58	b	2,3				
U-00002				40	CFR	75	G							

Continuation Sheet 1 of 1

New York State Department of Environmental Conservation
Air Permit Application Form

NYCRR Part 201-2.6
Environmental Conservation Law

DEC ID											
3	-	3	3	5	6	-	0	0	1	3	6

Section IV - Emission Unit Information

Emission Unit	Emission Point	Process	Emission Source	Emission Unit State Only Requirements (continuation)										
				Title	Type	Part	Subpart	Section	Subdiv.	Parag.	Subparag.	Clause	Subcl.	
U-00002				6	NYCRR	204	5							
U-00002				6	NYCRR	204	6							
U-00002				6	NYCRR	204	7							
U-00002				6	NYCRR	204	8							
U-00002				6	NYCRR	204	9							
U-00002				6	NYCRR	237	1	4	a					
U-00002				6	NYCRR	237	1	6,7						
U-00002				6	NYCRR	237	2							
U-00002				6	NYCRR	237	3							
U-00002				6	NYCRR	237	4	1						
U-00002				6	NYCRR	237	5	3	a					
U-00002				6	NYCRR	237	6							
U-00002				6	NYCRR	237	7							
U-00002				6	NYCRR	237	8							
U-00002				6	NYCRR	238	1	4,6,7						
U-00002				6	NYCRR	238	2							
U-00002				6	NYCRR	238	3							
U-00002				6	NYCRR	238	4	1						
U-00002				6	NYCRR	238	5	3						
U-00002				6	NYCRR	238	6							
U-00002				6	NYCRR	238	7							
U-00002				6	NYCRR	238	8							
U-00002				6	NYCRR	242	1	6,7						
U-00002				6	NYCRR	242	2,3,4,5							
U-00002				6	NYCRR	242	6,7,8,10							
U-00002				6	NYCRR	227	1	2	a	1				
U-00002				6	NYCRR	227	1	3						
U-00002				6	NYCRR	227	1	4	d					
U-00002				6	NYCRR	227	2	4	e	2				
U-00002				6	NYCRR	227	2	6						

**New York State Department of Environmental Conservation
Air Permit Application Form**

Department of
Environmental Conservation

DEC ID											
3	-	3	3	5	6	-	0	0	1	3	6

Section III - Facility Information

Facility Compliance Certification (continuation)									
Rule Citation									
Title	Type	Part	Subpart	Section	Subdivision	Paragraph	Subparagraph	Clause	Subclause
6	NYCRR	231	7	6					
<input checked="" type="checkbox"/> Applicable Federal Requirement			<input type="checkbox"/> Capping		CAS No.		Contaminant Name		
<input type="checkbox"/> State Only Requirement					007446-09-5		Sulfur Dioxide		
Monitoring Information									
<input type="checkbox"/> Continuous Emission Monitoring					<input type="checkbox"/> Monitoring of Process or Control Device Parameters as a Surrogate				
<input type="checkbox"/> Intermittent Emission Testing					<input checked="" type="checkbox"/> Work Practice Involving Specific Operations				
<input type="checkbox"/> Ambient Air Monitoring					<input type="checkbox"/> Record Keeping/Maintenance Procedures				
Description									
Facility Sulfur Dioxide emissions are subject to BACT and the fuel sulfur limit listed in 6 NYCRR 225-1.2 (g). The facility is proposing to limit the sulfur content no greater than 0.0015% sulfur by weight. The sulfur content of the fuel will be certified by the vendor and monitored by the facility.									
Work Practice		Process Material				Reference Test Method			
Type	Code	Description							
04	007	number 2 oil				ASTM D 2880-71			
		Parameter				Manufacturer Name/Model No.			
Code	Description								
32	sulfur content								
Limit				Limit Units					
Upper		Lower		Code	Description				
0.0015				57	Percent by weight.				
Averaging Method			Monitoring Frequency			Reporting Requirements			
Code	Description		Code	Description		Code	Description		
01	Maximum - not to be exceeded		11	per delivery		15	Annually		

Continuation Sheet 1 of 54

New York State Department of Environmental Conservation
Air Permit Application Form

Department of
Environmental
Conservation

DEC ID											
3	-	3	3	5	6	-	0	0	1	3	6

Section IV - Emission Unit Information

Emission Unit Compliance Certification (continuation)									
Rule Citation									
Title	Type	Part	Subpart	Section	Subdivision	Paragraph	Subparagraph	Clause	Subclause
6	NYCRR	231	5	4					
<input checked="" type="checkbox"/> Applicable Federal Requirement						<input type="checkbox"/> State Only Requirement		<input type="checkbox"/> Capping	
Emission Unit	Emission Point	Process	Emission Source	CAS No.	Contaminant Name				
U-00001	EP001	P3A	CT001	0NY210-00-0	Oxides of Nitrogen				
Monitoring Information									
<input checked="" type="checkbox"/> Continuous Emission Monitoring			<input type="checkbox"/> Monitoring of Process or Control Device Parameters as a Surrogate						
<input type="checkbox"/> Intermittent Emission Testing			<input type="checkbox"/> Work Practice Involving Specific Operations						
<input type="checkbox"/> Ambient Air Monitoring			<input type="checkbox"/> Record Keeping/Maintenance Procedures						
Description									
The facility will maintain a 6.0 ppmvd (corrected to 15% O ₂) NO _x emission limit when firing on fuel oil from the combustion turbine based upon Higher Heating Value (HHV) of the fuel oil. This emission limit applies at all loads except during startup, shutdown and fuel switching. The facility will use CEMS to monitor NO _x stack emissions. The emission limits represents LAER.									
Work Practice		Process Material				Reference Test Method			
Type	Code	Description				Reference Test Method			
						40 CFR 60, Appendix A, Method 7E			
Parameter		Manufacturer Name/Model No.							
Code	Description				Manufacturer Name/Model No.				
23	Concentration								
Limit			Limit Units						
Upper	Lower	Code	Description						
6.0		275	parts per million by volume (dry, corrected to 15% O ₂)						
Averaging Method			Monitoring Frequency			Reporting Requirements			
Code	Description		Code	Description		Code	Description		
47	3-Hour Block Average		01	Continuous		07	Quarterly		

Continuation Sheet 2 of 54

New York State Department of Environmental Conservation
Air Permit Application Form

Department of
 Environmental
 Conservation

DEC ID											
3	-	3	3	5	6	-	0	0	1	3	6

Section IV - Emission Unit Information

Emission Unit Compliance Certification (continuation)									
Rule Citation									
Title	Type	Part	Subpart	Section	Subdivision	Paragraph	Subparagraph	Clause	Subclause
6	NYCRR	231	5	4					
<input checked="" type="checkbox"/> Applicable Federal Requirement						<input type="checkbox"/> State Only Requirement		<input type="checkbox"/> Capping	
Emission Unit	Emission Point	Process	Emission Source	CAS No.	Contaminant Name				
U-00002	EP002	P03	CT002	0NY210-00-0	Oxides of Nitrogen				
Monitoring Information									
<input checked="" type="checkbox"/> Continuous Emission Monitoring			<input type="checkbox"/> Monitoring of Process or Control Device Parameters as a Surrogate						
<input type="checkbox"/> Intermittent Emission Testing			<input type="checkbox"/> Work Practice Involving Specific Operations						
<input type="checkbox"/> Ambient Air Monitoring			<input type="checkbox"/> Record Keeping/Maintenance Procedures						
Description									
The facility will maintain a 6.0 ppmvd (corrected to 15% O ₂) NO _x emission limit when firing fuel oil from the combustion turbine based upon Higher Heating Value (HHV) of the fuel oil. This emission limit applies at all loads except during startup, shutdown and fuel switching. The facility will use CEMS to monitor NO _x stack emissions. The emission limits represents LAER.									
Work Practice		Process Material				Reference Test Method			
Type	Code	Description				Reference Test Method			
						40 CFR 60, Appendix A, Method 7E			
Parameter		Manufacturer Name/Model No.							
Code	Description				Manufacturer Name/Model No.				
23	Concentration								
Limit			Limit Units						
Upper	Lower	Code	Description						
6.0		275	parts per million by volume (dry, corrected to 15% O ₂)						
Averaging Method			Monitoring Frequency			Reporting Requirements			
Code	Description		Code	Description		Code	Description		
47	3-Hour Block Average		01	Continuous		07	Quarterly		

Continuation Sheet 3 of 54

New York State Department of Environmental Conservation
Air Permit Application Form

Department of
 Environmental
 Conservation

DEC ID											
3	-	3	3	5	6	-	0	0	1	3	6

Section IV - Emission Unit Information

Emission Unit Compliance Certification (continuation)									
Rule Citation									
Title	Type	Part	Subpart	Section	Subdivision	Paragraph	Subparagraph	Clause	Subclause
6	NYCRR	231	5	4					
<input checked="" type="checkbox"/> Applicable Federal Requirement						<input type="checkbox"/> State Only Requirement		<input type="checkbox"/> Capping	
Emission Unit	Emission Point	Process	Emission Source	CAS No.	Contaminant Name				
U-00003	EP003	P3B	AUX01	0NY210-00-0	Oxides of Nitrogen				
Monitoring Information									
<input type="checkbox"/> Continuous Emission Monitoring					<input type="checkbox"/> Monitoring of Process or Control Device Parameters as a Surrogate				
<input checked="" type="checkbox"/> Intermittent Emission Testing					<input type="checkbox"/> Work Practice Involving Specific Operations				
<input type="checkbox"/> Ambient Air Monitoring					<input type="checkbox"/> Record Keeping/Maintenance Procedures				
Description									
The facility will maintain 0.0450 lb/mmBtu NOx emission limit when firing natural gas from the auxiliary boiler based upon Higher Heating Value (HHV) of the natural gas. This emission limit applies at all loads except during startup and shutdown. The facility will use vendor emission guarantees and/or stack testing to ensure compliance with the LAER emission limit, as required.									
Work Practice		Process Material				Reference Test Method			
Type	Code	Description				Reference Test Method			
						40 CFR 60, Appendix A, Method 7E			
Parameter		Manufacturer Name/Model No.							
Code	Description	Manufacturer Name/Model No.							
23	Concentration								
Limit			Limit Units						
Upper	Lower	Code	Description						
0.045		07	pounds per million Btus						
Averaging Method			Monitoring Frequency			Reporting Requirements			
Code	Description	Code	Description	Code	Description				
08	1-Hour Average	13	single occurrence	01	once / batch or monitoring occurrence				

Continuation Sheet 4 of 54

New York State Department of Environmental Conservation
Air Permit Application Form

Department of
 Environmental
 Conservation

DEC ID											
3	-	3	3	5	6	-	0	0	1	3	6

Section IV - Emission Unit Information

Emission Unit Compliance Certification (continuation)									
Rule Citation									
Title	Type	Part	Subpart	Section	Subdivision	Paragraph	Subparagraph	Clause	Subclause
6	NYCRR	231	5	4					
<input checked="" type="checkbox"/> Applicable Federal Requirement						<input type="checkbox"/> State Only Requirement		<input type="checkbox"/> Capping	
Emission Unit	Emission Point	Process	Emission Source	CAS No.	Contaminant Name				
U-00001	EP001	P1A,P3A	CT001	0NY998-00-0	VOC				
Monitoring Information									
<input type="checkbox"/> Continuous Emission Monitoring					<input type="checkbox"/> Monitoring of Process or Control Device Parameters as a Surrogate				
<input checked="" type="checkbox"/> Intermittent Emission Testing					<input type="checkbox"/> Work Practice Involving Specific Operations				
<input type="checkbox"/> Ambient Air Monitoring					<input type="checkbox"/> Record Keeping/Maintenance Procedures				
Description									
The facility will maintain a 0.7 ppmvd (corrected to 15% O ₂) VOC emission limit from the combustion turbine based upon Higher Heating Value (HHV) of the natural gas (without duct burner) and fuel oil. This emission limit applies at all loads except during startup, shutdown and fuel switching. Stack testing will be used to demonstrate compliance with the LAER emission limit.									
Work Practice		Process Material				Reference Test Method			
Type	Code	Description				Reference Test Method			
						40 CFR Part 60, Appendix A, Method 25A, Method 18			
Parameter		Manufacturer Name/Model No.							
Code	Description	Manufacturer Name/Model No.							
23	Concentration								
Limit			Limit Units						
Upper	Lower	Code	Description						
0.7		275	parts per million by volume (dry, corrected to 15% O ₂)						
Averaging Method			Monitoring Frequency			Reporting Requirements			
Code	Description	Code	Description	Code	Description				
08	1-Hour Average	13	single occurrence	01	once / batch or monitoring occurrence				

Continuation Sheet 5 of 54

New York State Department of Environmental Conservation
Air Permit Application Form

Department of
Environmental
Conservation

DEC ID											
3	-	3	3	5	6	-	0	0	1	3	6

Section IV - Emission Unit Information

Emission Unit Compliance Certification (continuation)									
Rule Citation									
Title	Type	Part	Subpart	Section	Subdivision	Paragraph	Subparagraph	Clause	Subclause
6	NYCRR	231	5	4					
<input checked="" type="checkbox"/> Applicable Federal Requirement						<input type="checkbox"/> State Only Requirement		<input type="checkbox"/> Capping	
Emission Unit	Emission Point	Process	Emission Source	CAS No.	Contaminant Name				
U-00001	EP001	P2A	CT001	0NY998-00-0	VOC				
Monitoring Information									
<input type="checkbox"/> Continuous Emission Monitoring			<input type="checkbox"/> Monitoring of Process or Control Device Parameters as a Surrogate						
<input checked="" type="checkbox"/> Intermittent Emission Testing			<input type="checkbox"/> Work Practice Involving Specific Operations						
<input type="checkbox"/> Ambient Air Monitoring			<input type="checkbox"/> Record Keeping/Maintenance Procedures						
Description									
The facility will maintain a 1.8 ppmvd (corrected to 15% O ₂) VOC emission limit from the combustion turbine (with duct burner) based upon Higher Heating Value (HHV) of the natural gas. This emission limit applies at all loads except during startup, shutdown and fuel switching. Stack testing will be used to demonstrate compliance with the LAER emission limit.									
Work Practice		Process Material				Reference Test Method			
Type	Code	Description				Reference Test Method			
						40 CFR Part 60, Appendix A, Method 25A			
Parameter		Manufacturer Name/Model No.							
Code	Description				Manufacturer Name/Model No.				
23	Concentration								
Limit			Limit Units						
Upper	Lower	Code	Description						
1.8		275	parts per million by volume (dry, corrected to 15% O ₂)						
Averaging Method			Monitoring Frequency			Reporting Requirements			
Code	Description		Code	Description		Code	Description		
08	1-Hour Average		13	single occurrence		01	once / batch or monitoring occurrence		

Continuation Sheet 6 of 54

New York State Department of Environmental Conservation
Air Permit Application Form

Department of
 Environmental
 Conservation

DEC ID											
3	-	3	3	5	6	-	0	0	1	3	6

Section IV - Emission Unit Information

Emission Unit Compliance Certification (continuation)										
Rule Citation										
Title	Type	Part	Subpart	Section	Subdivision	Paragraph	Subparagraph	Clause	Subclause	
6	NYCRR	231	5	4						
<input checked="" type="checkbox"/> Applicable Federal Requirement					<input type="checkbox"/> State Only Requirement			<input type="checkbox"/> Capping		
Emission Unit	Emission Point	Process	Emission Source	CAS No.	Contaminant Name					
U-00002	EP002	P01,P03	CT002	0NY998-00-0	VOC					
Monitoring Information										
<input type="checkbox"/> Continuous Emission Monitoring					<input type="checkbox"/> Monitoring of Process or Control Device Parameters as a Surrogate					
<input checked="" type="checkbox"/> Intermittent Emission Testing					<input type="checkbox"/> Work Practice Involving Specific Operations					
<input type="checkbox"/> Ambient Air Monitoring					<input type="checkbox"/> Record Keeping/Maintenance Procedures					
Description										
The facility will maintain a 0.7 ppmvd (corrected to 15% O ₂) VOC emission limit from the combustion turbine based upon Higher Heating Value (HHV) of the natural gas (without duct burner) and fuel oil. This emission limit applies at all loads except during startup, shutdown and fuel switching. Stack testing will be used to demonstrate compliance with the LAER emission limit.										
Work Practice		Process Material				Reference Test Method				
Type	Code	Description								
						40 CFR Part 60, Appendix A, Method 25A, Method 18				
		Parameter				Manufacturer Name/Model No.				
Code	Description									
23	Concentration									
Limit			Limit Units							
Upper	Lower	Code	Description							
0.7		275	parts per million by volume (dry, corrected to 15% O ₂)							
Averaging Method			Monitoring Frequency			Reporting Requirements				
Code	Description		Code	Description		Code	Description			
08	1-Hour Average		13	single occurrence		01	once / batch or monitoring occurrence			

Continuation Sheet 7 of 54

New York State Department of Environmental Conservation
Air Permit Application Form

Department of
 Environmental
 Conservation

DEC ID											
3	-	3	3	5	6	-	0	0	1	3	6

Section IV - Emission Unit Information

Emission Unit Compliance Certification (continuation)									
Rule Citation									
Title	Type	Part	Subpart	Section	Subdivision	Paragraph	Subparagraph	Clause	Subclause
6	NYCRR	231	5	4					
<input checked="" type="checkbox"/> Applicable Federal Requirement						<input type="checkbox"/> State Only Requirement		<input type="checkbox"/> Capping	
Emission Unit	Emission Point	Process	Emission Source	CAS No.	Contaminant Name				
U-00002	EP002	P02	CT002	0NY998-00-0	VOC				
Monitoring Information									
<input type="checkbox"/> Continuous Emission Monitoring			<input type="checkbox"/> Monitoring of Process or Control Device Parameters as a Surrogate						
<input checked="" type="checkbox"/> Intermittent Emission Testing			<input type="checkbox"/> Work Practice Involving Specific Operations						
<input type="checkbox"/> Ambient Air Monitoring			<input type="checkbox"/> Record Keeping/Maintenance Procedures						
Description									
The facility will maintain a 1.8 ppmvd (corrected to 15% O ₂) VOC emission limit from the combustion turbine (with duct burner) based upon Higher Heating Value (HHV) of the natural gas. This emission limit applies at all loads except during startup, shutdown and fuel switching. Stack testing will be used to demonstrate compliance with the LAER emission limit.									
Work Practice		Process Material				Reference Test Method			
Type	Code	Description				40 CFR Part 60, Appendix A, Method 25A, Method 18			
Parameter		Manufacturer Name/Model No.							
Code	Description								
23	Concentration								
Limit			Limit Units						
Upper	Lower	Code	Description						
1.8		275	parts per million by volume (dry, corrected to 15% O ₂)						
Averaging Method			Monitoring Frequency			Reporting Requirements			
Code	Description		Code	Description		Code	Description		
08	1-Hour Average		13	single occurrence		01	once / batch or monitoring occurrence		

Continuation Sheet 6 of 54

**New York State Department of Environmental Conservation
Air Permit Application Form**

Department of Environmental Conservation

DEC ID											
3	-	3	3	5	6	-	0	0	1	3	6

Section IV - Emission Unit Information

Emission Unit Compliance Certification (continuation)									
Rule Citation									
Title	Type	Part	Subpart	Section	Subdivision	Paragraph	Subparagraph	Clause	Subclause
6	NYCRR	231	5	4					
<input checked="" type="checkbox"/> Applicable Federal Requirement						<input type="checkbox"/> State Only Requirement		<input type="checkbox"/> Capping	
Emission Unit	Emission Point	Process	Emission Source	CAS No.	Contaminant Name				
U-00003	EP003	P3B	AUX01	0NY998-00-0	VOC				
Monitoring Information									
<input type="checkbox"/> Continuous Emission Monitoring					<input type="checkbox"/> Monitoring of Process or Control Device Parameters as a Surrogate				
<input checked="" type="checkbox"/> Intermittent Emission Testing					<input type="checkbox"/> Work Practice Involving Specific Operations				
<input type="checkbox"/> Ambient Air Monitoring					<input type="checkbox"/> Record Keeping/Maintenance Procedures				
Description									
<p>The facility will maintain a 0.0038 lb/mmBtu VOC emission limit when firing on natural gas from the auxiliary boiler based upon Higher Heating Value (HHV) of the natural gas. This emission limit applies at all loads except during startup and shutdown. The facility will use vendor emission guarantees and/or stack testing to ensure compliance with the LAER emission limit, as required</p>									
Work Practice		Process Material				Reference Test Method			
Type	Code	Description							
						40 CFR Part 60, Appendix A, Method 25A, Method 18			
		Parameter				Manufacturer Name/Model No.			
Code	Description								
23	Concentration								
Limit			Limit Units						
Upper	Lower	Code	Description						
0.0038		7	pounds per million Btus						
Averaging Method			Monitoring Frequency			Reporting Requirements			
Code	Description		Code	Description		Code	Description		
08	1-Hour Average		13	single occurrence		01	once / batch or monitoring occurrence		

New York State Department of Environmental Conservation
Air Permit Application Form

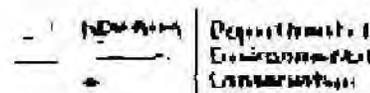

DEC ID											
3	-	3	3	5	6	-	0	0	1	3	6

Section IV - Emission Unit Information

Emission Unit Compliance Certification (continuation)									
Rule Citation									
Title	Type	Part	Subpart	Section	Subdivision	Paragraph	Subparagraph	Clause	Subclause
6	NYCRR	231	7	6					
<input checked="" type="checkbox"/> Applicable Federal Requirement <input type="checkbox"/> State Only Requirement						<input type="checkbox"/> Capping			
Emission Unit	Emission Point	Process	Emission Source	CAS No.	Contaminant Name				
U-00001	EP001	P1A,P3A	CT001	000630-08-0	Carbon Monoxide				
Monitoring Information									
<input checked="" type="checkbox"/> Continuous Emission Monitoring			<input type="checkbox"/> Monitoring of Process or Control Device Parameters as a Surrogate						
<input type="checkbox"/> Intermittent Emission Testing			<input type="checkbox"/> Work Practice Involving Specific Operations						
<input type="checkbox"/> Ambient Air Monitoring			<input type="checkbox"/> Record Keeping/Maintenance Procedures						
Description									
<p>The facility will maintain a 2.0 ppmvd (corrected to 15% O₂) CO emission limit for the combustion turbine based upon the Higher Heating Value (HHV) of the the natural gas (without duct burner) and fuel oil. This emission limit applies at all loads except during startup, shutdown and fuel switching. The facility will use CEMS to monitor CO stack emissions. The emission limit represents BACT.</p>									
Work Practice		Process Material				Reference Test Method			
Type	Code	Description							
						40 CFR Part 60, Appendix A, Method 10			
Parameter		Manufacturer Name/Model No.							
Code	Description								
23	Concentration								
Limit			Limit Units						
Upper	Lower	Code	Description						
2.0		275	parts per million by volume (dry, corrected to 15% O ₂)						
Averaging Method			Monitoring Frequency			Reporting Requirements			
Code	Description		Code	Description		Code	Description		
47	3-Hour Block Average		01	Continuous		07	Quarterly		

New York State Department of Environmental Conservation
Air Permit Application Form

Department of
Environmental
Conservation

DEC ID											
3	-	3	3	5	6	-	0	0	1	3	6

Section IV - Emission Unit Information

Emission Unit Compliance Certification (continuation)										
Rule Citation										
Title	Type	Part	Subpart	Section	Subdivision	Paragraph	Subparagraph	Clause	Subclause	
6	NYCRR	231	7	6						
<input checked="" type="checkbox"/> Applicable Federal Requirement					<input type="checkbox"/> State Only Requirement			<input type="checkbox"/> Capping		
Emission Unit	Emission Point	Process	Emission Source	CAS No.	Contaminant Name					
U-00002	EP002	P01,P03	CT002	000630-08-0	Carbon Monoxide					
Monitoring Information										
<input checked="" type="checkbox"/> Continuous Emission Monitoring					<input type="checkbox"/> Monitoring of Process or Control Device Parameters as a Surrogate					
<input type="checkbox"/> Intermittent Emission Testing					<input type="checkbox"/> Work Practice Involving Specific Operations					
<input type="checkbox"/> Ambient Air Monitoring					<input type="checkbox"/> Record Keeping/Maintenance Procedures					
Description										
The facility will maintain a 2.0 ppmvd (corrected to 15% O ₂) CO emission limit for the combustion turbine based upon the Higher Heating Value (HHV) of the the natural gas (without duct burner) and fuel oil. This emission limit applies at all loads except during startup, shutdown and fuel switching. The facility will use CEMS to monitor CO stack emissions. The emission limit represents BACT.										
Work Practice		Process Material				Reference Test Method				
Type	Code	Description				Reference Test Method				
						40 CFR Part 60, Appendix A, Method 10				
		Parameter				Manufacturer Name/Model No.				
Code	Description				Manufacturer Name/Model No.					
23	Concentration									
Limit			Limit Units							
Upper	Lower	Code	Description							
2.0		275	parts per million by volume (dry, corrected to 15% O ₂)							
Averaging Method			Monitoring Frequency			Reporting Requirements				
Code	Description		Code	Description		Code	Description			
47	3-Hour Block Average		01	Continuous		07	Quarterly			

Continuation Sheet 11 of 64

New York State Department of Environmental Conservation
Air Permit Application Form

Department of
Environmental
Conservation

DEC ID											
3	-	3	3	5	6	-	0	0	1	3	6

Section IV - Emission Unit Information

Emission Unit Compliance Certification (continuation)										
Rule Citation										
Title	Type	Part	Subpart	Section	Subdivision	Paragraph	Subparagraph	Clause	Subclause	
6	NYCRR	231	7	6						
<input checked="" type="checkbox"/> Applicable Federal Requirement					<input type="checkbox"/> State Only Requirement			<input type="checkbox"/> Capping		
Emission Unit	Emission Point	Process	Emission Source	CAS No.	Contaminant Name					
U-00001	EP001	P2A	CT001	000630-08-0	Carbon Monoxide					
Monitoring Information										
<input checked="" type="checkbox"/> Continuous Emission Monitoring			<input type="checkbox"/> Monitoring of Process or Control Device Parameters as a Surrogate							
<input type="checkbox"/> Intermittent Emission Testing			<input type="checkbox"/> Work Practice Involving Specific Operations							
<input type="checkbox"/> Ambient Air Monitoring			<input type="checkbox"/> Record Keeping/Maintenance Procedures							
Description										
The facility will maintain a 3.4 ppmvd (corrected to 15% O ₂) CO emission limit for the combustion turbine (with duct burner) based upon the Higher Heating Value (HHV) of the natural gas. This emission limit applies at all loads except during startup, shutdown and fuel switching. The facility will use CEMS to monitor CO stack emissions. The emission limit represents BACT.										
Work Practice		Process Material				Reference Test Method				
Type	Code	Description				Reference Test Method				
						40 CFR Part 60, Appendix A, Method 10				
Parameter		Manufacturer Name/Model No.								
Code	Description				Manufacturer Name/Model No.					
23	Concentration									
Limit			Limit Units							
Upper	Lower	Code	Description							
3.4		275	parts per million by volume (dry, corrected to 15% O ₂)							
Averaging Method			Monitoring Frequency			Reporting Requirements				
Code	Description		Code	Description		Code	Description			
47	3-Hour Block Average		01	Continuous		07	Quarterly			

Continuation Sheet 12 of 64

New York State Department of Environmental Conservation
Air Permit Application Form

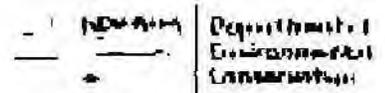

DEC ID											
3	-	3	3	5	6	-	0	0	1	3	6

Section IV - Emission Unit Information

Emission Unit Compliance Certification (continuation)										
Rule Citation										
Title	Type	Part	Subpart	Section	Subdivision	Paragraph	Subparagraph	Clause	Subclause	
6	NYCRR	231	7	6						
<input checked="" type="checkbox"/> Applicable Federal Requirement					<input type="checkbox"/> State Only Requirement			<input type="checkbox"/> Capping		
Emission Unit	Emission Point	Process	Emission Source	CAS No.	Contaminant Name					
U-00002	EP002	P02	CT002	000630-08-0	Carbon Monoxide					
Monitoring Information										
<input checked="" type="checkbox"/> Continuous Emission Monitoring			<input type="checkbox"/> Monitoring of Process or Control Device Parameters as a Surrogate							
<input type="checkbox"/> Intermittent Emission Testing			<input type="checkbox"/> Work Practice Involving Specific Operations							
<input type="checkbox"/> Ambient Air Monitoring			<input type="checkbox"/> Record Keeping/Maintenance Procedures							
Description										
<p>The facility will maintain a 3.4 ppmvd (corrected to 15% O₂) CO emission limit for the combustion turbine (with duct burner) based upon the Higher Heating Value (HHV) of the natural gas. This emission limit applies at all loads except during startup, shutdown and fuel switching. The facility will use CEMS to monitor CO stack emissions. The emission limit represents BACT.</p>										
Work Practice		Process Material				Reference Test Method				
Type	Code	Description				40 CFR Part 60, Appendix A, Method 10				
Parameter		Manufacturer Name/Model No.								
Code	Description									
23	Concentration									
Limit			Limit Units							
Upper	Lower	Code	Description							
3.4		275	parts per million by volume (dry, corrected to 15% O ₂)							
Averaging Method			Monitoring Frequency			Reporting Requirements				
Code	Description		Code	Description		Code	Description			
47	3-Hour Block Average		01	Continuous		07	Quarterly			

Continuation Sheet 13 of 64

New York State Department of Environmental Conservation
Air Permit Application Form

Department of
 Environmental
 Conservation

DEC ID											
3	-	3	3	5	6	-	0	0	1	3	6

Section IV - Emission Unit Information

Emission Unit Compliance Certification (continuation)									
Rule Citation									
Title	Type	Part	Subpart	Section	Subdivision	Paragraph	Subparagraph	Clause	Subclause
6	NYCRR	231	7	6					
<input checked="" type="checkbox"/> Applicable Federal Requirement						<input type="checkbox"/> State Only Requirement		<input type="checkbox"/> Capping	
Emission Unit	Emission Point	Process	Emission Source	CAS No.	Contaminant Name				
U-00003	EP003	P3B	AUX01	000630-08-0	Carbon Monoxide				
Monitoring Information									
<input type="checkbox"/> Continuous Emission Monitoring					<input type="checkbox"/> Monitoring of Process or Control Device Parameters as a Surrogate				
<input checked="" type="checkbox"/> Intermittent Emission Testing					<input type="checkbox"/> Work Practice Involving Specific Operations				
<input type="checkbox"/> Ambient Air Monitoring					<input type="checkbox"/> Record Keeping/Maintenance Procedures				
Description									
The facility will maintain a 0.0721 lb/mmBtu CO emission limit when burning natural gas from the auxiliary boiler based upon Higher Heating Value (HHV) of the natural gas. This emission limit applies at all loads except during startup and shutdown. The facility will use vendor emission guarantees and/or stack testing to ensure compliance with the BACT emission limit, as required.									
Work Practice		Process Material				Reference Test Method			
Type	Code	Description							
						40 CFR Part 60, Appendix A, Method 10			
		Parameter				Manufacturer Name/Model No.			
Code	Description								
23	Concentration								
Limit			Limit Units						
Upper	Lower	Code	Description						
0.0721		7	pounds per million Btus						
Averaging Method			Monitoring Frequency			Reporting Requirements			
Code	Description		Code	Description		Code	Description		
08	1-Hour Average		13	single occurrence		01	once / batch or monitoring occurrence		

Continuation Sheet 14 of 54

New York State Department of Environmental Conservation
Air Permit Application Form

Department of
Environmental
Conservation

DEC ID											
3	-	3	3	5	6	-	0	0	1	3	6

Section IV - Emission Unit Information

Emission Unit Compliance Certification (continuation)									
Rule Citation									
Title	Type	Part	Subpart	Section	Subdivision	Paragraph	Subparagraph	Clause	Subclause
6	NYCRR	231	7	6					
<input checked="" type="checkbox"/> Applicable Federal Requirement						<input type="checkbox"/> State Only Requirement		<input type="checkbox"/> Capping	
Emission Unit	Emission Point	Process	Emission Source	CAS No.		Contaminant Name			
U-00001	EP001	P1A,P2A	CT001	0NY075-00-0, 0NY075-00-5		PARTICULATES, PM-10			
Monitoring Information									
<input type="checkbox"/> Continuous Emission Monitoring					<input type="checkbox"/> Monitoring of Process or Control Device Parameters as a Surrogate				
<input checked="" type="checkbox"/> Intermittent Emission Testing					<input type="checkbox"/> Work Practice Involving Specific Operations				
<input type="checkbox"/> Ambient Air Monitoring					<input type="checkbox"/> Record Keeping/Maintenance Procedures				
Description									
The facility will maintain a 0.0073 lb/mmBtu PM emission limit with and without duct burner from the combustion turbine based upon Higher Heating Value (HHV) of the natural gas. The emission limits applies at all load except during startup, shutdown and fuel switching. The facility will demonstrate compliance with the BACT emission limit by stack testing.									
Work Practice		Process Material				Reference Test Method			
Type	Code	Description				EPA RM 5, 201/201A or 202			
Parameter		Manufacturer Name/Model No.							
Code	Description								
23	Concentration								
Limit			Limit Units						
Upper	Lower	Code	Description						
0.0073		7	pounds per Million Btus						
Averaging Method			Monitoring Frequency			Reporting Requirements			
Code	Description		Code	Description		Code	Description		
08	1-Hour Average		13	single occurrence		01	once / batch or monitoring occurrence		

Continuation Sheet 15 of 15

New York State Department of Environmental Conservation
Air Permit Application Form

Department of
 Environmental
 Conservation

DEC ID											
3	-	3	3	5	6	-	0	0	1	3	6

Section IV - Emission Unit Information

Emission Unit Compliance Certification (continuation)									
Rule Citation									
Title	Type	Part	Subpart	Section	Subdivision	Paragraph	Subparagraph	Clause	Subclause
6	NYCRR	231	7	6					
<input checked="" type="checkbox"/> Applicable Federal Requirement						<input type="checkbox"/> State Only Requirement		<input type="checkbox"/> Capping	
Emission Unit	Emission Point	Process	Emission Source	CAS No.		Contaminant Name			
U-00002	EP002	P01,P02	CT002	0NY075-00-0, 0NY075-00-5		PARTICULATES, PM-10			
Monitoring Information									
<input type="checkbox"/> Continuous Emission Monitoring					<input type="checkbox"/> Monitoring of Process or Control Device Parameters as a Surrogate				
<input checked="" type="checkbox"/> Intermittent Emission Testing					<input type="checkbox"/> Work Practice Involving Specific Operations				
<input type="checkbox"/> Ambient Air Monitoring					<input type="checkbox"/> Record Keeping/Maintenance Procedures				
Description									
The facility will maintain a 0.0073 lb/mmBtu PM emission limit with and without duct burner from the combustion turbine based upon Higher Heating Value (HHV) of the natural gas. The emission limits applies at all load except during startup, shutdown and fuel switching. The facility will demonstrate compliance with the BACT emission limit by stack testing.									
Work Practice		Process Material				Reference Test Method			
Type	Code	Description				EPA RM 5, 201/201A or 202			
Parameter		Manufacturer Name/Model No.							
Code	Description								
23	Concentration								
Limit			Limit Units						
Upper	Lower	Code	Description						
0.0073		7	pounds per Million Btus						
Averaging Method			Monitoring Frequency			Reporting Requirements			
Code	Description		Code	Description		Code	Description		
08	1-Hour Average		13	single occurrence		01	once / batch or monitoring occurrence		

Continuation Sheet 16 of 54

New York State Department of Environmental Conservation
Air Permit Application Form

Department of
 Environmental
 Conservation

DEC ID											
3	-	3	3	5	6	-	0	0	1	3	6

Section IV - Emission Unit Information

Emission Unit Compliance Certification (continuation)										
Rule Citation										
Title	Type	Part	Subpart	Section	Subdivision	Paragraph	Subparagraph	Clause	Subclause	
6	NYCRR	231	7	6						
<input checked="" type="checkbox"/> Applicable Federal Requirement					<input type="checkbox"/> State Only Requirement			<input type="checkbox"/> Capping		
Emission Unit	Emission Point	Process	Emission Source	CAS No.		Contaminant Name				
U-00001	EP001	P3A	CT001	0NY075-00-0, 0NY075-00-5		Particulates, PM-10				
Monitoring Information										
<input type="checkbox"/> Continuous Emission Monitoring					<input type="checkbox"/> Monitoring of Process or Control Device Parameters as a Surrogate					
<input checked="" type="checkbox"/> Intermittent Emission Testing					<input type="checkbox"/> Work Practice Involving Specific Operations					
<input type="checkbox"/> Ambient Air Monitoring					<input type="checkbox"/> Record Keeping/Maintenance Procedures					
Description										
The facility will maintain a 0.0368 lb/mmBtu PM emission limit when firing fuel oil from the combustion turbine based upon Higher Heating Value (HHV) of the fuel oil. The emission limit applies at all loads except during startup, shutdown and fuel switching. The facility will demonstrate compliance with the BACT emission limit by stack testing.										
Work Practice		Process Material				Reference Test Method				
Type	Code	Description								
						EPA RM 5, 201/201A or 202				
		Parameter				Manufacturer Name/Model No.				
Code	Description									
23	Concentration									
Limit			Limit Units							
Upper	Lower	Code	Description							
0.0368		7	pounds per Million Btus							
Averaging Method			Monitoring Frequency			Reporting Requirements				
Code	Description		Code	Description		Code	Description			
08	1-Hour Average		13	single occurrence		01	once / batch or monitoring occurrence			

Continuation Sheet 17 of 54

New York State Department of Environmental Conservation
Air Permit Application Form

Department of
 Environmental
 Conservation

DEC ID											
3	-	3	3	5	6	-	0	0	1	3	6

Section IV - Emission Unit Information

Emission Unit Compliance Certification (continuation)									
Rule Citation									
Title	Type	Part	Subpart	Section	Subdivision	Paragraph	Subparagraph	Clause	Subclause
6	NYCRR	231	7	6					
<input checked="" type="checkbox"/> Applicable Federal Requirement						<input type="checkbox"/> State Only Requirement		<input type="checkbox"/> Capping	
Emission Unit	Emission Point	Process	Emission Source	CAS No.		Contaminant Name			
U-00002	EP002	P03	CT002	0NY075-00-0, 0NY075-00-5		Particulates, PM-10			
Monitoring Information									
<input type="checkbox"/> Continuous Emission Monitoring					<input type="checkbox"/> Monitoring of Process or Control Device Parameters as a Surrogate				
<input checked="" type="checkbox"/> Intermittent Emission Testing					<input type="checkbox"/> Work Practice Involving Specific Operations				
<input type="checkbox"/> Ambient Air Monitoring					<input type="checkbox"/> Record Keeping/Maintenance Procedures				
Description									
The facility will maintain a 0.0368 lb/mmBtu PM emission limit when firing fuel oil from the combustion turbine based upon Higher Heating Value (HHV) of the fuel oil. The emission limit applies at all loads except during startup, shutdown and fuel switching. The facility will demonstrate compliance with the BACT emission limit by stack testing.									
Work Practice		Process Material				Reference Test Method			
Type	Code	Description				Reference Test Method			
						EPA RM 5, 201/201A or 202			
Parameter		Manufacturer Name/Model No.							
Code	Description				Manufacturer Name/Model No.				
23	Concentration								
Limit			Limit Units						
Upper	Lower	Code	Description						
0.0368		7	pounds per Million Btus						
Averaging Method			Monitoring Frequency			Reporting Requirements			
Code	Description		Code	Description		Code	Description		
08	1-Hour Average		13	single occurrence		01	once / batch or monitoring occurrence		

Continuation Sheet 18 of 54

New York State Department of Environmental Conservation
Air Permit Application Form

Department of
 Environmental
 Conservation

DEC ID											
3	-	3	3	5	6	-	0	0	1	3	6

Section IV - Emission Unit Information

Emission Unit Compliance Certification (continuation)										
Rule Citation										
Title	Type	Part	Subpart	Section	Subdivision	Paragraph	Subparagraph	Clause	Subclause	
6	NYCRR	231	7	6						
<input checked="" type="checkbox"/> Applicable Federal Requirement					<input type="checkbox"/> State Only Requirement			<input type="checkbox"/> Capping		
Emission Unit	Emission Point	Process	Emission Source	CAS No.		Contaminant Name				
U-00003	EP003	P3B	AUX01	0NY075-00-0, 0NY075-00-5		Particulates, PM-10				
Monitoring Information										
<input type="checkbox"/> Continuous Emission Monitoring					<input type="checkbox"/> Monitoring of Process or Control Device Parameters as a Surrogate					
<input checked="" type="checkbox"/> Intermittent Emission Testing					<input type="checkbox"/> Work Practice Involving Specific Operations					
<input type="checkbox"/> Ambient Air Monitoring					<input type="checkbox"/> Record Keeping/Maintenance Procedures					
Description										
The facility will maintain a 0.0063 lb/mmBtu PM emission limit when firing natural gas from the auxiliary boiler based on the Higher Heating Value (HHV) of the natural gas. This emission limit applies at all loads except during startup and shutdown. The facility will use vendor emission guarantees and/or stack testing to ensure compliance with the BACT emission limit, as required.										
Work Practice		Process Material				Reference Test Method				
Type	Code	Description								
						EPA RM 5, 201A/201, and 202				
		Parameter				Manufacturer Name/Model No.				
Code	Description									
23	Concentration									
Limit			Limit Units							
Upper	Lower	Code	Description							
0.0063		7	pounds per Million Btus							
Averaging Method			Monitoring Frequency			Reporting Requirements				
Code	Description		Code	Description		Code	Description			
08	1-Hour Average		13	single occurrence		01	once / batch or monitoring occurrence			

Continuation Sheet 19 of 54

New York State Department of Environmental Conservation
Air Permit Application Form

Department of
 Environmental
 Conservation

DEC ID											
3	-	3	3	5	6	-	0	0	1	3	6

Section IV - Emission Unit Information

Emission Unit Compliance Certification (continuation)										
Rule Citation										
Title	Type	Part	Subpart	Section	Subdivision	Paragraph	Subparagraph	Clause	Subclause	
6	NYCRR	231	7	6						
<input checked="" type="checkbox"/> Applicable Federal Requirement					<input type="checkbox"/> State Only Requirement			<input type="checkbox"/> Capping		
Emission Unit	Emission Point	Process	Emission Source	CAS No.	Contaminant Name					
U-00001	EP001	P1A,P2A	CT001	007446-09-5	Sulfur Dioxide					
Monitoring Information										
<input type="checkbox"/> Continuous Emission Monitoring					<input type="checkbox"/> Monitoring of Process or Control Device Parameters as a Surrogate					
<input checked="" type="checkbox"/> Intermittent Emission Testing					<input type="checkbox"/> Work Practice Involving Specific Operations					
<input type="checkbox"/> Ambient Air Monitoring					<input type="checkbox"/> Record Keeping/Maintenance Procedures					
Description										
<p>The facility will maintain a 0.0022 lb/mmBtu SO₂ emission limit from the combustion turbine (with and without duct burner) based on the Higher Heating Value (HHV) of the natural gas. This emission limit applies at all loads except during startup, shutdown and fuel switching. The facility will demonstrate compliance with the BACT emission limit by limiting sulfur content of the natural gas to 0.8 grains/100 SCF. The sulfur content of the natural gas will be verified through a certification or analysis provided by the fuels supplier and monitored by the facility.</p>										
Work Practice		Process Material				Reference Test Method				
Type	Code	Description				Reference Test Method				
04	012	natural gas				ASTM 5504				
Parameter		Manufacturer Name/Model No.								
Code	Description				Manufacturer Name/Model No.					
32	Sulfur Content									
Limit			Limit Units							
Upper	Lower	Code	Description							
0.8		13	grains per 100 dscf							
Averaging Method			Monitoring Frequency			Reporting Requirements				
Code	Description		Code	Description		Code	Description			
01	Maximum not to be exceeded		14	as required		10	Upon Request			

Continuation Sheet 20 of 54

New York State Department of Environmental Conservation
Air Permit Application Form

Department of
 Environmental
 Conservation

DEC ID											
3	-	3	3	5	6	-	0	0	1	3	6

Section IV - Emission Unit Information

Emission Unit Compliance Certification (continuation)										
Rule Citation										
Title	Type	Part	Subpart	Section	Subdivision	Paragraph	Subparagraph	Clause	Subclause	
6	NYCRR	231	7	6						
<input checked="" type="checkbox"/> Applicable Federal Requirement					<input type="checkbox"/> State Only Requirement			<input type="checkbox"/> Capping		
Emission Unit	Emission Point	Process	Emission Source	CAS No.	Contaminant Name					
U-00002	EP002	P01,P02	CT002	007446-09-5	Sulfur Dioxide					
Monitoring Information										
<input type="checkbox"/> Continuous Emission Monitoring					<input type="checkbox"/> Monitoring of Process or Control Device Parameters as a Surrogate					
<input checked="" type="checkbox"/> Intermittent Emission Testing					<input type="checkbox"/> Work Practice Involving Specific Operations					
<input type="checkbox"/> Ambient Air Monitoring					<input type="checkbox"/> Record Keeping/Maintenance Procedures					
Description										
<p>The facility will maintain a 0.0022 lb/mmBtu SO₂ emission limit from the combustion turbine (with and without duct burner) based on the Higher Heating Value (HHV) of the natural gas. This emission limit applies at all loads except during startup, shutdown and fuel switching. The facility will demonstrate compliance with the BACT emission limit by limiting sulfur content of the natural gas to 0.8 grains/100 SCF. The sulfur content of the natural gas will be verified through a certification or analysis provided by the fuels supplier and monitored by the facility.</p>										
Work Practice		Process Material				Reference Test Method				
Type	Code	Description								
04	012	natural gas				ASTM 5504				
Parameter		Manufacturer Name/Model No.								
Code	Description									
32	Sulfur Content									
Limit			Limit Units							
Upper	Lower	Code	Description							
0.8		13	grains per 100 dscf							
Averaging Method			Monitoring Frequency			Reporting Requirements				
Code	Description		Code	Description		Code	Description			
01	Maximum not to be exceeded		14	as required		10	Upon Request			

Continuation Sheet 21 of 54

New York State Department of Environmental Conservation
Air Permit Application Form

Department of
 Environmental
 Conservation

DEC ID											
3	-	3	3	5	6	-	0	0	1	3	6

Section IV - Emission Unit Information

Emission Unit Compliance Certification (continuation)										
Rule Citation										
Title	Type	Part	Subpart	Section	Subdivision	Paragraph	Subparagraph	Clause	Subclause	
6	NYCRR	231	7	6						
<input checked="" type="checkbox"/> Applicable Federal Requirement					<input type="checkbox"/> State Only Requirement			<input type="checkbox"/> Capping		
Emission Unit	Emission Point	Process	Emission Source	CAS No.	Contaminant Name					
U-00001	EP001	P3A	CT001	007446-09-5	Sulfur Dioxide					
Monitoring Information										
<input type="checkbox"/> Continuous Emission Monitoring					<input type="checkbox"/> Monitoring of Process or Control Device Parameters as a Surrogate					
<input checked="" type="checkbox"/> Intermittent Emission Testing					<input type="checkbox"/> Work Practice Involving Specific Operations					
<input type="checkbox"/> Ambient Air Monitoring					<input type="checkbox"/> Record Keeping/Maintenance Procedures					
Description										
<p>The facility will maintain a 0.0015 lb/mmBtu SO₂ emission limit when firing fuel oil from the combustion turbine based on the Higher Heating Value (HHV) of the fuel oil. This emission limit applies at all loads except during startup, shutdown and fuel switching. The facility will demonstrate compliance with the BACT emission limit by maintaining compliance with the fuel oil sulfur limit of 0.0015%. The sulfur content of the fuel will be certified by the vendor and monitored by the facility.</p>										
Work Practice		Process Material				Reference Test Method				
Type	Code	Description				Reference Test Method				
04	007	Number 2 Oil				ASTM D 2880-71				
Parameter		Manufacturer Name/Model No.								
Code	Description				Manufacturer Name/Model No.					
32	Sulfur Content									
Limit			Limit Units							
Upper	Lower	Code	Description							
0.0015		57	percent by weight							
Averaging Method			Monitoring Frequency			Reporting Requirements				
Code	Description		Code	Description		Code	Description			
01	Maximum not to be exceeded		11	Per Delivery		10	Upon Request			

Continuation Sheet 22 of 54

New York State Department of Environmental Conservation
Air Permit Application Form

Department of
Environmental
Conservation

DEC ID											
3	-	3	3	5	6	-	0	0	1	3	6

Section IV - Emission Unit Information

Emission Unit Compliance Certification (continuation)										
Rule Citation										
Title	Type	Part	Subpart	Section	Subdivision	Paragraph	Subparagraph	Clause	Subclause	
6	NYCRR	231	7	6						
<input checked="" type="checkbox"/> Applicable Federal Requirement					<input type="checkbox"/> State Only Requirement			<input type="checkbox"/> Capping		
Emission Unit	Emission Point	Process	Emission Source	CAS No.	Contaminant Name					
U-00002	EP002	P03	CT002	007446-09-5	Sulfur Dioxide					
Monitoring Information										
<input type="checkbox"/> Continuous Emission Monitoring					<input type="checkbox"/> Monitoring of Process or Control Device Parameters as a Surrogate					
<input checked="" type="checkbox"/> Intermittent Emission Testing					<input type="checkbox"/> Work Practice Involving Specific Operations					
<input type="checkbox"/> Ambient Air Monitoring					<input type="checkbox"/> Record Keeping/Maintenance Procedures					
Description										
<p>The facility will maintain a 0.0015 lb/mmBtu SO₂ emission limit when firing fuel oil from the combustion turbine based on the Higher Heating Value (HHV) of the fuel oil. This emission limit applies at all loads except during startup, shutdown and fuel switching. The facility will demonstrate compliance with the BACT emission limit by maintaining compliance with the fuel oil sulfur limit of 0.0015%. The sulfur content of the fuel will be certified by the vendor and monitored by the facility.</p>										
Work Practice		Process Material				Reference Test Method				
Type	Code	Description				Reference Test Method				
04	007	Number 2 Oil				ASTM D 2880-71				
Parameter		Manufacturer Name/Model No.								
Code	Description				Manufacturer Name/Model No.					
32	Sulfur Content									
Limit			Limit Units							
Upper	Lower	Code	Description							
0.0015		57	percent by weight							
Averaging Method			Monitoring Frequency			Reporting Requirements				
Code	Description		Code	Description		Code	Description			
01	Maximum not to be exceeded		11	Per Delivery		10	Upon Request			

Continuation Sheet 23 of 54

New York State Department of Environmental Conservation
Air Permit Application Form

Department of
 Environmental
 Conservation

DEC ID											
3	-	3	3	5	6	-	0	0	1	3	6

Section IV - Emission Unit Information

Emission Unit Compliance Certification (continuation)										
Rule Citation										
Title	Type	Part	Subpart	Section	Subdivision	Paragraph	Subparagraph	Clause	Subclause	
6	NYCRR	231	7	6						
<input checked="" type="checkbox"/> Applicable Federal Requirement					<input type="checkbox"/> State Only Requirement			<input type="checkbox"/> Capping		
Emission Unit	Emission Point	Process	Emission Source	CAS No.	Contaminant Name					
U-00003	EP003	P3B	AUX01	007446-09-5	Sulfur Dioxide					
Monitoring Information										
<input type="checkbox"/> Continuous Emission Monitoring					<input type="checkbox"/> Monitoring of Process or Control Device Parameters as a Surrogate					
<input checked="" type="checkbox"/> Intermittent Emission Testing					<input type="checkbox"/> Work Practice Involving Specific Operations					
<input type="checkbox"/> Ambient Air Monitoring					<input type="checkbox"/> Record Keeping/Maintenance Procedures					
Description										
The facility will maintain a 0.0022 lb/mm Btu SO ₂ emission limit from the auxiliary boiler based upon Higher Heating Value (HHV) of the natural gas. This emission limit applies at all loads except during startup and shutdown. The facility will demonstrate compliance with the BACT emission limit by limiting the sulfur content of the natural gas to 0.8 grains/100 scf.										
Work Practice		Process Material				Reference Test Method				
Type	Code	Description				Reference Test Method				
						ASTM 5504				
Parameter		Manufacturer Name/Model No.								
Code	Description				Manufacturer Name/Model No.					
32	Sulfur Content									
Limit			Limit Units							
Upper	Lower	Code	Description							
0.8		13	grains per 100 dscf							
Averaging Method			Monitoring Frequency			Reporting Requirements				
Code	Description		Code	Description		Code	Description			
01	Maximum not to be exceeded		13	single occurrence		01	once / batch or monitoring occurrence			

Continuation Sheet 24 of 54

New York State Department of Environmental Conservation
Air Permit Application Form

Department of
 Environmental
 Conservation

DEC ID											
3	-	3	3	5	6	-	0	0	1	3	6

Section IV - Emission Unit Information

Emission Unit Compliance Certification (continuation)										
Rule Citation										
Title	Type	Part	Subpart	Section	Subdivision	Paragraph	Subparagraph	Clause	Subclause	
6	NYCRR	231	7	6						
<input checked="" type="checkbox"/> Applicable Federal Requirement					<input type="checkbox"/> State Only Requirement			<input type="checkbox"/> Capping		
Emission Unit	Emission Point	Process	Emission Source	CAS No.	Contaminant Name					
U-00001	EP001	P1A,P2A	CT001	007664-93-9	Sulfuric Acid					
Monitoring Information										
<input type="checkbox"/> Continuous Emission Monitoring					<input type="checkbox"/> Monitoring of Process or Control Device Parameters as a Surrogate					
<input checked="" type="checkbox"/> Intermittent Emission Testing					<input type="checkbox"/> Work Practice Involving Specific Operations					
<input type="checkbox"/> Ambient Air Monitoring					<input type="checkbox"/> Record Keeping/Maintenance Procedures					
Description										
<p>The facility will maintain a 0.0007 lb/mmBtu sulfuric acid mist emission limit from the combustion turbine (with and without duct burner) based upon Higher Heating Value (HHV) of the natural gas. This emission limit applies at all loads except during startup, shutdown and fuel switching. The facility will demonstrate compliance with the BACT emission limit by limiting sulfur content of the natural gas to 0.8 grains/100 scf. The sulfur content of the natural gas will be verified through a certification or analysis provided by the fuels supplier and monitored by the facility.</p>										
Work Practice		Process Material				Reference Test Method				
Type	Code	Description				Reference Test Method				
04	012	Natural Gas				ASTM 5504				
Parameter		Manufacturer Name/Model No.								
Code	Description				Manufacturer Name/Model No.					
32	Sulfur Content									
Limit			Limit Units							
Upper	Lower	Code	Description							
0.8		13	grains per 100 dscf							
Averaging Method			Monitoring Frequency			Reporting Requirements				
Code	Description		Code	Description		Code	Description			
01	Maximum not to be exceeded		14	as required		10	Upon Request			

Continuation Sheet 25 of 54

New York State Department of Environmental Conservation
Air Permit Application Form

Department of
 Environmental
 Conservation

DEC ID											
3	-	3	3	5	6	-	0	0	1	3	6

Section IV - Emission Unit Information

Emission Unit Compliance Certification (continuation)									
Rule Citation									
Title	Type	Part	Subpart	Section	Subdivision	Paragraph	Subparagraph	Clause	Subclause
6	NYCRR	231	7	6					
<input checked="" type="checkbox"/> Applicable Federal Requirement						<input type="checkbox"/> State Only Requirement		<input type="checkbox"/> Capping	
Emission Unit	Emission Point	Process	Emission Source	CAS No.	Contaminant Name				
U-00002	EP002	P01,P02	CT002	007664-93-9	Sulfuric Acid				
Monitoring Information									
<input type="checkbox"/> Continuous Emission Monitoring					<input type="checkbox"/> Monitoring of Process or Control Device Parameters as a Surrogate				
<input checked="" type="checkbox"/> Intermittent Emission Testing					<input type="checkbox"/> Work Practice Involving Specific Operations				
<input type="checkbox"/> Ambient Air Monitoring					<input type="checkbox"/> Record Keeping/Maintenance Procedures				
Description									
<p>The facility will maintain a 0.0007 lb/mmBtu sulfuric acid mist emission limit from the combustion turbine (with and without duct burner) based upon Higher Heating Value (HHV) of the natural gas. This emission limit applies at all loads except during startup, shutdown and fuel switching. The facility will demonstrate compliance with the BACT emission limit by limiting sulfur content of the natural gas to 0.8 grains/100 scf. The sulfur content of the natural gas will be verified through a certification or analysis provided by the fuels supplier and monitored by the facility.</p>									
Work Practice		Process Material				Reference Test Method			
Type	Code	Description				Reference Test Method			
04	012	Natural Gas				ASTM 5504			
Parameter		Manufacturer Name/Model No.							
Code	Description				Manufacturer Name/Model No.				
32	Sulfur Content								
Limit			Limit Units						
Upper	Lower	Code	Description						
0.8		13	grains per 100 dscf						
Averaging Method			Monitoring Frequency			Reporting Requirements			
Code	Description		Code	Description		Code	Description		
01	Maximum not to be exceeded		14	as required		10	Upon Request		

Continuation Sheet 26 of 54

New York State Department of Environmental Conservation
Air Permit Application Form

Department of
Environmental
Conservation

DEC ID											
3	-	3	3	5	6	-	0	0	1	3	6

Section IV - Emission Unit Information

Emission Unit Compliance Certification (continuation)									
Rule Citation									
Title	Type	Part	Subpart	Section	Subdivision	Paragraph	Subparagraph	Clause	Subclause
6	NYCRR	231	7	6					
<input checked="" type="checkbox"/> Applicable Federal Requirement						<input type="checkbox"/> State Only Requirement		<input type="checkbox"/> Capping	
Emission Unit	Emission Point	Process	Emission Source	CAS No.	Contaminant Name				
U-00001	EP001	P3A	CT001	007664-93-9	Sulfuric Acid				
Monitoring Information									
<input type="checkbox"/> Continuous Emission Monitoring					<input type="checkbox"/> Monitoring of Process or Control Device Parameters as a Surrogate				
<input checked="" type="checkbox"/> Intermittent Emission Testing					<input type="checkbox"/> Work Practice Involving Specific Operations				
<input type="checkbox"/> Ambient Air Monitoring					<input type="checkbox"/> Record Keeping/Maintenance Procedures				
Description									
<p>The facility will maintain a 0.0005 lb/mm Btu sulfuric acid mist emission limit when firing fuel oil from the combustion turbine based upon Higher Heating Value (HHV) of the gas and fuel oil. This emission limit applies at all loads except during startup, shutdown and fuel switching. The facility will demonstrate compliance with the BACT emission limit by maintaining compliance with the fuel oil sulfur limit of 0.0015%. The sulfur content of the fuel will be certified by the vendor and monitored by the facility.</p>									
Work Practice		Process Material				Reference Test Method			
Type	Code	Description				Reference Test Method			
04	007	Number 2 Oil				ASTM D 2880-71			
Parameter		Manufacturer Name/Model No.							
Code	Description				Manufacturer Name/Model No.				
32	Sulfur Content								
Limit			Limit Units						
Upper	Lower	Code	Description						
0.0015		57	percent by weight						
Averaging Method			Monitoring Frequency			Reporting Requirements			
Code	Description		Code	Description		Code	Description		
01	Maximum not to be exceeded		11	Per Delivery		10	Upon Request		

Continuation Sheet 27 of 54

New York State Department of Environmental Conservation
Air Permit Application Form

Department of
 Environmental
 Conservation

DEC ID											
3	-	3	3	5	6	-	0	0	1	3	6

Section IV - Emission Unit Information

Emission Unit Compliance Certification (continuation)										
Rule Citation										
Title	Type	Part	Subpart	Section	Subdivision	Paragraph	Subparagraph	Clause	Subclause	
6	NYCRR	231	7	6						
<input checked="" type="checkbox"/> Applicable Federal Requirement					<input type="checkbox"/> State Only Requirement			<input type="checkbox"/> Capping		
Emission Unit	Emission Point	Process	Emission Source	CAS No.	Contaminant Name					
U-00002	EP002	P03	CT002	007664-93-9	Sulfuric Acid					
Monitoring Information										
<input type="checkbox"/> Continuous Emission Monitoring					<input type="checkbox"/> Monitoring of Process or Control Device Parameters as a Surrogate					
<input checked="" type="checkbox"/> Intermittent Emission Testing					<input type="checkbox"/> Work Practice Involving Specific Operations					
<input type="checkbox"/> Ambient Air Monitoring					<input type="checkbox"/> Record Keeping/Maintenance Procedures					
Description										
<p>The facility will maintain a 0.0005 lb/mm Btu sulfuric acid mist emission limit from the combustion turbine (with and without duct burner) based upon Higher Heating Value (HHV) of the gas and fuel oil. This emission limit applies at all loads except during startup, shutdown and fuel switching. The facility will demonstrate compliance with the BACT emission limit by maintaining compliance with the fuel oil sulfur limit of 0.0015%. The sulfur content of the fuel will be certified by the vendor and monitored by the facility.</p>										
Work Practice		Process Material				Reference Test Method				
Type	Code	Description				Reference Test Method				
04	007	Number 2 Oil				ASTM D 2880-71				
Parameter		Manufacturer Name/Model No.								
Code	Description				Manufacturer Name/Model No.					
32	Sulfur Content									
Limit			Limit Units							
Upper	Lower	Code	Description							
0.0015		57	percent by weight							
Averaging Method			Monitoring Frequency			Reporting Requirements				
Code	Description		Code	Description		Code	Description			
01	Maximum not to be exceeded		11	Per Delivery		10	Upon Request			

Continuation Sheet 28 of 54

New York State Department of Environmental Conservation
Air Permit Application Form

Department of
 Environmental
 Conservation

DEC ID											
3	-	3	3	5	6	-	0	0	1	3	6

Section IV - Emission Unit Information

Emission Unit Compliance Certification (continuation)									
Rule Citation									
Title	Type	Part	Subpart	Section	Subdivision	Paragraph	Subparagraph	Clause	Subclause
40	CFR	60	43	3	c				
<input checked="" type="checkbox"/> Applicable Federal Requirement						<input type="checkbox"/> State Only Requirement		<input type="checkbox"/> Capping	
Emission Unit	Emission Point	Process	Emission Source	CAS No.	Contaminant Name				
U-00003	EP003	P3B	AUX01						
Monitoring Information									
<input type="checkbox"/> Continuous Emission Monitoring					<input type="checkbox"/> Monitoring of Process or Control Device Parameters as a Surrogate				
<input checked="" type="checkbox"/> Intermittent Emission Testing					<input type="checkbox"/> Work Practice Involving Specific Operations				
<input type="checkbox"/> Ambient Air Monitoring					<input type="checkbox"/> Record Keeping/Maintenance Procedures				
Description									
No owner or operator of a combustion installation shall operate the installation in such a way to emit greater than 20 percent opacity except for one six minute period per hour, not to exceed 27 percent, based upon the six minute average in reference test Method 9 in Appendix A of 40 CFR 60.									
Work Practice		Process Material				Reference Test Method			
Type	Code	Description				Reference Test Method			
						40 CFR 60, Method 9			
Parameter		Manufacturer Name/Model No.							
Code	Description				Manufacturer Name/Model No.				
01	Opacity								
Limit			Limit Units						
Upper	Lower	Code	Description						
20	0	136	Percent						
Averaging Method			Monitoring Frequency			Reporting Requirements			
Code	Description		Code	Description		Code	Description		
18	6-min average		13	single occurrence		01	once / batch or monitoring occurrence		

Continuation Sheet 30 of 54

New York State Department of Environmental Conservation
Air Permit Application Form

Department of
 Environmental
 Conservation

DEC ID											
3	-	3	3	5	6	-	0	0	1	3	6

Section IV - Emission Unit Information

Emission Unit Compliance Certification (continuation)									
Rule Citation									
Title	Type	Part	Subpart	Section	Subdivision	Paragraph	Subparagraph	Clause	Subclause
6	NYCRR	231	7	6					
<input checked="" type="checkbox"/> Applicable Federal Requirement						<input type="checkbox"/> State Only Requirement		<input type="checkbox"/> Capping	
Emission Unit	Emission Point	Process	Emission Source	CAS No.	Contaminant Name				
U-00003	EP003	P3B	AUX01	007664-93-9	Sulfuric Acid				
Monitoring Information									
<input type="checkbox"/> Continuous Emission Monitoring					<input type="checkbox"/> Monitoring of Process or Control Device Parameters as a Surrogate				
<input checked="" type="checkbox"/> Intermittent Emission Testing					<input type="checkbox"/> Work Practice Involving Specific Operations				
<input type="checkbox"/> Ambient Air Monitoring					<input type="checkbox"/> Record Keeping/Maintenance Procedures				
Description									
<p>The facility will maintain a 0.0002 lb/mm Btu sulfuric acid mist emission limit from the auxiliary boiler based upon Higher Heating Value (HHV) of the natural gas. This emission limit applies at all loads except during startup and shutdown. The facility will demonstrate compliance with the BACT emission limit by limiting the sulfur content of the natural gas to 0.8 grains/100 scf. The sulfur content of the natural gas will be verified through a certification or analysis provided by the fuels supplier and monitored by the facility.</p>									
Work Practice		Process Material				Reference Test Method			
Type	Code	Description				Reference Test Method			
04	012	Natural Gas				ASTM 5504			
Parameter		Manufacturer Name/Model No.							
Code	Description				Manufacturer Name/Model No.				
32	Sulfur Content								
Limit			Limit Units						
Upper	Lower	Code	Description						
0.8		13	grains per 100 dscf						
Averaging Method			Monitoring Frequency			Reporting Requirements			
Code	Description		Code	Description		Code	Description		
01	Maximum not to be exceeded		14	as required		10	Upon Request		

Continuation Sheet 29 of 54

New York State Department of Environmental Conservation
Air Permit Application Form

Department of
 Environmental
 Conservation

DEC ID											
3	-	3	3	5	6	-	0	0	1	3	6

Section IV - Emission Unit Information

Emission Unit Compliance Certification (continuation)									
Rule Citation									
Title	Type	Part	Subpart	Section	Subdivision	Paragraph	Subparagraph	Clause	Subclause
6	NYCRR	200	7						
<input checked="" type="checkbox"/> Applicable Federal Requirement						<input type="checkbox"/> State Only Requirement		<input type="checkbox"/> Capping	
Emission Unit	Emission Point	Process	Emission Source	CAS No.	Contaminant Name				
U-00001	EP001	P1A,P2A,P3A	CT001	007664-41-7	Ammonia				
Monitoring Information									
<input checked="" type="checkbox"/> Continuous Emission Monitoring			<input type="checkbox"/> Monitoring of Process or Control Device Parameters as a Surrogate						
<input type="checkbox"/> Intermittent Emission Testing			<input type="checkbox"/> Work Practice Involving Specific Operations						
<input type="checkbox"/> Ambient Air Monitoring			<input type="checkbox"/> Record Keeping/Maintenance Procedures						
Description									
The facility will maintain a 5.0 ppmvd (corrected to 15% O2) limit applies during all fuels being fired and duct burner operations.. This emission limit applies at all loads except during startup, shutdown and fuel switching. The facility will use CEMS to monitor Ammonia stack emissions.									
Work Practice		Process Material				Reference Test Method			
Type	Code	Description							
	154	Ammonia				40 CFR 75 & 40 CFR 60 Appendices A/B/F			
		Parameter				Manufacturer Name/Model No.			
Code	Description								
Limit			Limit Units						
Upper	Lower	Code	Description						
5.0		275	parts per million by volume (dry, corrected to 15% O2)						
Averaging Method			Monitoring Frequency			Reporting Requirements			
Code	Description		Code	Description		Code	Description		
47	3-hour block average		01	Continuous		07	Quarterly		

Continuation Sheet 31 of 54

New York State Department of Environmental Conservation
Air Permit Application Form

Department of
 Environmental
 Conservation

DEC ID											
3	-	3	3	5	6	-	0	0	1	3	6

Section IV - Emission Unit Information

Emission Unit Compliance Certification (continuation)									
Rule Citation									
Title	Type	Part	Subpart	Section	Subdivision	Paragraph	Subparagraph	Clause	Subclause
6	NYCRR	200	7						
<input checked="" type="checkbox"/> Applicable Federal Requirement						<input type="checkbox"/> State Only Requirement		<input type="checkbox"/> Capping	
Emission Unit	Emission Point	Process	Emission Source	CAS No.	Contaminant Name				
U-00002	EP002	P01,P02,P03	CT002	007664-41-7	Ammonia				
Monitoring Information									
<input checked="" type="checkbox"/> Continuous Emission Monitoring			<input type="checkbox"/> Monitoring of Process or Control Device Parameters as a Surrogate						
<input type="checkbox"/> Intermittent Emission Testing			<input type="checkbox"/> Work Practice Involving Specific Operations						
<input type="checkbox"/> Ambient Air Monitoring			<input type="checkbox"/> Record Keeping/Maintenance Procedures						
Description									
The facility will maintain a 5.0 ppmvd (corrected to 15% O2) limit applies during all fuels being fired and duct burner operations. This emission limit applies at all loads except during startup, shutdown and fuel switching. The facility will use CEMS to monitor Ammonia stack emissions.									
Work Practice		Process Material				Reference Test Method			
Type	Code	Description							
	154	Ammonia				40 CFR 75 & 40 CFR 60 Appendices A/B/F			
		Parameter				Manufacturer Name/Model No.			
Code	Description								
Limit			Limit Units						
Upper	Lower	Code	Description						
5.0		275	parts per million by volume (dry, corrected to 15% O2)						
Averaging Method			Monitoring Frequency			Reporting Requirements			
Code	Description		Code	Description		Code	Description		
47	3-hour block average		01	Continuous		07	Quarterly		

Continuation Sheet 32 of 54

**New York State Department of Environmental Conservation
Air Permit Application Form**

Department of
Environmental
Conservation

DEC ID											
3	-	3	3	5	6	-	0	0	1	3	6

Section IV - Emission Unit Information

Emission Unit Compliance Certification (continuation)											
Rule Citation											
Title	Type	Part	Subpart	Section	Subdivision	Paragraph	Subparagraph	Clause	Subclause		
6	NYCRR	200	7								
<input type="checkbox"/> Applicable Federal Requirement				<input checked="" type="checkbox"/> State Only Requirement				<input type="checkbox"/> Capping			
Emission Unit	Emission Point	Process	Emission Source	CAS No.		Contaminant Name					
				007664-41-7		Ammonia					
Monitoring Information											
<input type="checkbox"/> Continuous Emission Monitoring			<input type="checkbox"/> Monitoring of Process or Control Device Parameters as a Surrogate								
<input type="checkbox"/> Intermittent Emission Testing			<input checked="" type="checkbox"/> Work Practice Involving Specific Operations								
<input type="checkbox"/> Ambient Air Monitoring			<input type="checkbox"/> Record Keeping/Maintenance Procedures								
Description											
The facility will maintain records to verify concentration of ammonia stored on-site is less than 19%. The ammonia concentration will be certified by the vendor and monitored by the facility.											
Work Practice		Process Material				Reference Test Method					
Type	Code	Description									
04	154	Ammonia									
Parameter		Manufacturer Name/Model No.									
Code	Description										
Limit			Limit Units								
Upper	Lower	Code	Description								
19		21	percent by volume								
Averaging Method			Monitoring Frequency			Reporting Requirements					
Code	Description		Code	Description		Code	Description				
01	Maximum not to be exceeded		11	Per Delivery		15	annually (calendar)				

Continuation Sheet 33 of 54

New York State Department of Environmental Conservation
Air Permit Application Form

Department of
 Environmental
 Conservation

DEC ID											
3	-	3	3	5	6	-	0	0	1	3	6

Section IV - Emission Unit Information

Emission Unit Compliance Certification (continuation)									
Rule Citation									
Title	Type	Part	Subpart	Section	Subdivision	Paragraph	Subparagraph	Clause	Subclause
6	NYCRR	231	7	6					
<input checked="" type="checkbox"/> Applicable Federal Requirement						<input type="checkbox"/> State Only Requirement		<input type="checkbox"/> Capping	
Emission Unit	Emission Point	Process	Emission Source	CAS No.	Contaminant Name				
U-00001/U-00002	EP001/EP002	P1A,PO1	CT001/CT002						
Monitoring Information									
<input type="checkbox"/> Continuous Emission Monitoring					<input type="checkbox"/> Monitoring of Process or Control Device Parameters as a Surrogate				
<input checked="" type="checkbox"/> Intermittent Emission Testing					<input type="checkbox"/> Work Practice Involving Specific Operations				
<input type="checkbox"/> Ambient Air Monitoring					<input type="checkbox"/> Record Keeping/Maintenance Procedures				
Description									
The facility will have a heat rate of 7605 Btu/kW-hr (HHV) or less at ISO conditions without duct burner firing to achieve a design thermal efficiency.									
Work Practice		Process Material				Reference Test Method			
Type	Code	Description				ASME PTC 46-1996			
Parameter		Manufacturer Name/Model No.							
Code	Description								
38	Heat Input								
Limit			Limit Units						
Upper	Lower	Code	Description						
7605			BTU per kilowatt-hour						
Averaging Method			Monitoring Frequency			Reporting Requirements			
Code	Description		Code	Description		Code	Description		
60	maximum - not to exceed stated value		09	annually		14	semi-annually (calendar)		

Continuation Sheet 34 of 54

New York State Department of Environmental Conservation
Air Permit Application Form

Department of
 Environmental
 Conservation

DEC ID											
3	-	3	3	5	6	-	0	0	1	3	6

Section IV - Emission Unit Information

Emission Unit Compliance Certification (continuation)									
Rule Citation									
Title	Type	Part	Subpart	Section	Subdivision	Paragraph	Subparagraph	Clause	Subclause
6	NYCRR	251	3	a					
<input checked="" type="checkbox"/> Applicable Federal Requirement						<input type="checkbox"/> State Only Requirement		<input type="checkbox"/> Capping	
Emission Unit	Emission Point	Process	Emission Source	CAS No.	Contaminant Name				
U-00001/U-00002	EP001/EP002	P1A,P2A,P3A,P01,P02,P03	CT001/CT002	000124-38-9	Carbon Dioxide				
Monitoring Information									
<input checked="" type="checkbox"/> Continuous Emission Monitoring			<input type="checkbox"/> Monitoring of Process or Control Device Parameters as a Surrogate						
<input type="checkbox"/> Intermittent Emission Testing			<input type="checkbox"/> Work Practice Involving Specific Operations						
<input type="checkbox"/> Ambient Air Monitoring			<input type="checkbox"/> Record Keeping/Maintenance Procedures						
Description									
The facility are required to meet an emission rate of 925 pounds of CO2 per MW hour gross electrical output (output-based limit). These emission limits are measured on a 12-month rolling average basis, calculated by dividing the annual total of CO2 emissions over the relevant 12-month period by the annual total (gross) MW generated (output-based limit).									
Work Practice		Process Material				Reference Test Method			
Type	Code	Description							
Parameter		Manufacturer Name/Model No.							
Code	Description								
Limit			Limit Units						
Upper	Lower	Code	Description						
925		8	pounds per megawatt hour						
Averaging Method			Monitoring Frequency			Reporting Requirements			
Code	Description		Code	Description		Code	Description		
17	annual maximum rolled monthly		01	continuous		13	quarterly (calendar)		

Continuation Sheet 36 of 54

**New York State Department of Environmental Conservation
Air Permit Application**



Department of
Environmental
Conservation

DEC ID											
3	-	3	3	5	6	-	0	0	1	3	6

Request for Emission Reduction Credits Continuation Sheet(s)

Emission Source	0	0	0	0	1
-----------------	---	---	---	---	---

Emission Reduction Description

The facility purchased Emission Reductions Credits in the amount of 216.0 tons NOx and 75.0 tons VOC. Please see appendix 11 for additional information.

Contaminant Emission Reduction Data

Baseline Period ____/____/____ to ____/____/____		Reduction	
		Date	Method
CAS Number	Contaminant Name	ERC (lbs/yr)	
		Netting	Offset
0NY210 - 00 - 0	Oxides of Nitrogen		432,000.0
0NY998 - 00 - 0	Volatile Organic Compounds		150,000.0

Facility to Use Future Reduction

Name CPV Valley Energy Center						Application ID									
						-						-			
Location Address 3330 Route 6															
* City/ Town / Village Middletown								State NY				Zip 10940			

Use of Emission Reduction Credits Continuation Sheet(s)

Emission Source				
-----------------	--	--	--	--

Proposed Project Description

Contaminant Emissions Increase Data

CAS Number	Contaminant Name	Project Emission Potential (lbs/yr)

Statement of Compliance

All facilities under the ownership of this "owner/firm" are operating in compliance with all applicable requirements and state regulations including any compliance certification requirements under Section 114(a)(3) of the Clean Air Act Amendments of 1990, or are meeting the schedule of a consent order.

Source of Emission Reduction Credit - Facility

Name						Permit ID									
						-						-			
Location Address															
City/ Town / Village								State				Zip			

Emission Source	CAS Number	Contaminant Name	ERC (lbs/yr)	
			Netting	Offset

New York State Department of Environmental Conservation
Air Permit Application Form

Department of
 Environmental
 Conservation

DEC ID											
3	-	3	3	5	6	-	0	0	1	3	6

Section IV - Emission Unit Information

Emission Unit Compliance Certification (continuation)										
Rule Citation										
Title	Type	Part	Subpart	Section	Subdivision	Paragraph	Subparagraph	Clause	Subclause	
6	NYCRR	231	5	4						
<input checked="" type="checkbox"/> Applicable Federal Requirement					<input type="checkbox"/> State Only Requirement			<input type="checkbox"/> Capping		
Emission Unit	Emission Point	Process	Emission Source	CAS No.	Contaminant Name					
U-00004	EP004	P04		0NY998-00-0	VOC					
Monitoring Information										
<input type="checkbox"/> Continuous Emission Monitoring					<input type="checkbox"/> Monitoring of Process or Control Device Parameters as a Surrogate					
<input checked="" type="checkbox"/> Intermittent Emission Testing					<input type="checkbox"/> Work Practice Involving Specific Operations					
<input type="checkbox"/> Ambient Air Monitoring					<input type="checkbox"/> Record Keeping/Maintenance Procedures					
Description										
LAER is 0.0331 lb/mmBtu. Will be achieved using good combustion controls. Emission testing to be performed upon request of the Department.										
Work Practice		Process Material				Reference Test Method				
Type	Code	Description				Method 25A				
Parameter		Manufacturer Name/Model No.								
Code	Description									
23	concentration									
Limit			Limit Units							
Upper	Lower	Code	Description							
0.0331		7	pounds per million Btus							
Averaging Method			Monitoring Frequency			Reporting Requirements				
Code	Description		Code	Description		Code	Description			
08	1-hour average		14	as required		01	once / batch or monitoring occurrence			

Continuation Sheet 36 of 54

New York State Department of Environmental Conservation
Air Permit Application Form

Department of
 Environmental
 Conservation

DEC ID											
3	-	3	3	5	6	-	0	0	1	3	6

Section IV - Emission Unit Information

Emission Unit Compliance Certification (continuation)									
Rule Citation									
Title	Type	Part	Subpart	Section	Subdivision	Paragraph	Subparagraph	Clause	Subclause
6	NYCRR	231	5	4					
<input checked="" type="checkbox"/> Applicable Federal Requirement						<input type="checkbox"/> State Only Requirement		<input type="checkbox"/> Capping	
Emission Unit	Emission Point	Process	Emission Source	CAS No.	Contaminant Name				
U-00004	EP004	P04		0NY210-00-0	Oxides of Nitrogen				
Monitoring Information									
<input type="checkbox"/> Continuous Emission Monitoring			<input type="checkbox"/> Monitoring of Process or Control Device Parameters as a Surrogate						
<input checked="" type="checkbox"/> Intermittent Emission Testing			<input type="checkbox"/> Work Practice Involving Specific Operations						
<input type="checkbox"/> Ambient Air Monitoring			<input type="checkbox"/> Record Keeping/Maintenance Procedures						
Description									
LAER is 4.77 grams per brake horsepower-hour. Will be achieved using good combustion controls. Emission testing to be performed upon request of the Department.									
Work Practice		Process Material				Reference Test Method			
Type	Code	Description				Method 7E			
Parameter		Manufacturer Name/Model No.							
Code	Description								
23	concentration								
Limit			Limit Units						
Upper	Lower	Code	Description						
4.77		319	grams per brake horsepower-hour						
Averaging Method			Monitoring Frequency			Reporting Requirements			
Code	Description		Code	Description		Code	Description		
08	1-hour average		14	as required		01	once / batch or monitoring occurrence		

Continuation Sheet 36 of 54

**New York State Department of Environmental Conservation
Air Permit Application Form**

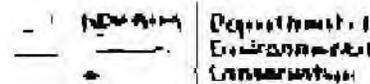

DEC ID											
3	-	3	3	5	6	-	0	0	1	3	6

Section IV - Emission Unit Information

Emission Unit Compliance Certification (continuation)									
Rule Citation									
Title	Type	Part	Subpart	Section	Subdivision	Paragraph	Subparagraph	Clause	Subclause
6	NYCRR	231	7	6					
<input checked="" type="checkbox"/> Applicable Federal Requirement						<input type="checkbox"/> State Only Requirement		<input type="checkbox"/> Capping	
Emission Unit	Emission Point	Process	Emission Source	CAS No.	Contaminant Name				
U-00004	EP004	P04		0NY075-00-0	PARTICULATES				
Monitoring Information									
<input type="checkbox"/> Continuous Emission Monitoring					<input type="checkbox"/> Monitoring of Process or Control Device Parameters as a Surrogate				
<input checked="" type="checkbox"/> Intermittent Emission Testing					<input type="checkbox"/> Work Practice Involving Specific Operations				
<input type="checkbox"/> Ambient Air Monitoring					<input type="checkbox"/> Record Keeping/Maintenance Procedures				
Description									
BACT is 0.03 g/hp-hr. Will be achieved using low sulfur fuel. Emission testing to be performed at the request of the Department.									
Work Practice		Process Material				Reference Test Method			
Type	Code	Description							
						Method 201/201A and 202			
Parameter		Manufacturer Name/Model No.							
Code	Description								
23	concentration								
Limit			Limit Units						
Upper	Lower	Code	Description						
0.03		319	grams per brake horsepower-hour						
Averaging Method			Monitoring Frequency			Reporting Requirements			
Code	Description		Code	Description		Code	Description		
08	1-hour average		14	as required		01	once / batch or monitoring occurrence		

New York State Department of Environmental Conservation
Air Permit Application Form

Department of
 Environmental
 Conservation

DEC ID											
3	-	3	3	5	6	-	0	0	1	3	6

Section IV - Emission Unit Information

Emission Unit Compliance Certification (continuation)										
Rule Citation										
Title	Type	Part	Subpart	Section	Subdivision	Paragraph	Subparagraph	Clause	Subclause	
6	NYCRR	231	7	6						
<input checked="" type="checkbox"/> Applicable Federal Requirement					<input type="checkbox"/> State Only Requirement			<input type="checkbox"/> Capping		
Emission Unit	Emission Point	Process	Emission Source	CAS No.	Contaminant Name					
U-00004	EP004	P04		0NY075-00-5	PM-10					
Monitoring Information										
<input type="checkbox"/> Continuous Emission Monitoring					<input type="checkbox"/> Monitoring of Process or Control Device Parameters as a Surrogate					
<input checked="" type="checkbox"/> Intermittent Emission Testing					<input type="checkbox"/> Work Practice Involving Specific Operations					
<input type="checkbox"/> Ambient Air Monitoring					<input type="checkbox"/> Record Keeping/Maintenance Procedures					
Description										
BACT is 0.03 g/hp-hr. Will be achieved using low sulfur fuel. Emission testing to be performed at the request of the Department.										
Work Practice		Process Material				Reference Test Method				
Type	Code	Description				Reference Test Method				
						Method 201/201A and 202				
Parameter		Manufacturer Name/Model No.								
Code	Description				Manufacturer Name/Model No.					
23	concentration									
Limit			Limit Units							
Upper	Lower	Code	Description							
0.03		319	grams per brake horsepower-hour							
Averaging Method			Monitoring Frequency			Reporting Requirements				
Code	Description		Code	Description		Code	Description			
08	1-hour average		14	as required		01	once / batch or monitoring occurrence			

Continuation Sheet 38 of 54

New York State Department of Environmental Conservation
Air Permit Application Form

Department of
Environmental
Conservation

DEC ID											
3	-	3	3	5	6	-	0	0	1	3	6

Section IV - Emission Unit Information

Emission Unit Compliance Certification (continuation)										
Rule Citation										
Title	Type	Part	Subpart	Section	Subdivision	Paragraph	Subparagraph	Clause	Subclause	
6	NYCRR	231	7	6						
<input checked="" type="checkbox"/> Applicable Federal Requirement					<input type="checkbox"/> State Only Requirement			<input type="checkbox"/> Capping		
Emission Unit	Emission Point	Process	Emission Source	CAS No.	Contaminant Name					
U-00004	EP004	P04		007446-09-5	SULFUR DIOXIDE					
Monitoring Information										
<input type="checkbox"/> Continuous Emission Monitoring					<input type="checkbox"/> Monitoring of Process or Control Device Parameters as a Surrogate					
<input checked="" type="checkbox"/> Intermittent Emission Testing					<input type="checkbox"/> Work Practice Involving Specific Operations					
<input type="checkbox"/> Ambient Air Monitoring					<input type="checkbox"/> Record Keeping/Maintenance Procedures					
Description										
BACT is 0.0014 lb/mmBtu. Will be achieved using low sulfur fuel. Emission testing to be performed at the request of the Department.										
Work Practice		Process Material				Reference Test Method				
Type	Code	Description				EPA approved methods				
Parameter		Manufacturer Name/Model No.								
Code	Description									
23	concentration									
Limit			Limit Units							
Upper	Lower	Code	Description							
0.0014		7	pounds per million Btus							
Averaging Method			Monitoring Frequency			Reporting Requirements				
Code	Description		Code	Description		Code	Description			
08	1-hour average		14	as required		01	once / batch or monitoring occurrence			

Continuation Sheet 39 of 54

New York State Department of Environmental Conservation
Air Permit Application Form

Department of
 Environmental
 Conservation

DEC ID											
3	-	3	3	5	6	-	0	0	1	3	6

Section IV - Emission Unit Information

Emission Unit Compliance Certification (continuation)									
Rule Citation									
Title	Type	Part	Subpart	Section	Subdivision	Paragraph	Subparagraph	Clause	Subclause
6	NYCRR	231	7	6					
<input checked="" type="checkbox"/> Applicable Federal Requirement						<input type="checkbox"/> State Only Requirement		<input type="checkbox"/> Capping	
Emission Unit	Emission Point	Process	Emission Source	CAS No.	Contaminant Name				
U-00004	EP004	P04		007664-93-9	SULFURIC ACID				
Monitoring Information									
<input type="checkbox"/> Continuous Emission Monitoring			<input type="checkbox"/> Monitoring of Process or Control Device Parameters as a Surrogate						
<input checked="" type="checkbox"/> Intermittent Emission Testing			<input type="checkbox"/> Work Practice Involving Specific Operations						
<input type="checkbox"/> Ambient Air Monitoring			<input type="checkbox"/> Record Keeping/Maintenance Procedures						
Description									
BACT is 0.0003 lb/mmBtu. Will be achieved using low sulfur fuel. Emission testing to be performed at the request of the Department.									
Work Practice		Process Material				Reference Test Method			
Type	Code	Description				EPA approved methods			
Parameter		Manufacturer Name/Model No.							
Code	Description								
23	concentration								
Limit			Limit Units						
Upper	Lower	Code	Description						
0.00003		7	pounds per million Btus						
Averaging Method			Monitoring Frequency			Reporting Requirements			
Code	Description		Code	Description		Code	Description		
08	1-hour average		14	as required		01	once / batch or monitoring occurrence		

Continuation Sheet 40 of 54

New York State Department of Environmental Conservation
Air Permit Application Form

Department of
 Environmental
 Conservation

DEC ID											
3	-	3	3	5	6	-	0	0	1	3	6

Section IV - Emission Unit Information

Emission Unit Compliance Certification (continuation)									
Rule Citation									
Title	Type	Part	Subpart	Section	Subdivision	Paragraph	Subparagraph	Clause	Subclause
6	NYCRR	231	7	6					
<input checked="" type="checkbox"/> Applicable Federal Requirement						<input type="checkbox"/> State Only Requirement		<input type="checkbox"/> Capping	
Emission Unit	Emission Point	Process	Emission Source	CAS No.	Contaminant Name				
U-00004	EP004	P04		000630-08-0	CARBON MONOXIDE				
Monitoring Information									
<input type="checkbox"/> Continuous Emission Monitoring			<input type="checkbox"/> Monitoring of Process or Control Device Parameters as a Surrogate						
<input checked="" type="checkbox"/> Intermittent Emission Testing			<input type="checkbox"/> Work Practice Involving Specific Operations						
<input type="checkbox"/> Ambient Air Monitoring			<input type="checkbox"/> Record Keeping/Maintenance Procedures						
Description									
BACT is 0.45 g/hp-hr. Will be achieved using good combustion controls. Emission testing to be performed at the request of the Department.									
Work Practice		Process Material				Reference Test Method			
Type	Code	Description				Method 10			
Parameter		Manufacturer Name/Model No.							
Code	Description								
23	concentration								
Limit			Limit Units						
Upper	Lower	Code	Description						
0.45		319	grams per brake horsepower-hour						
Averaging Method			Monitoring Frequency			Reporting Requirements			
Code	Description		Code	Description		Code	Description		
08	1-hour average		14	as required		01	once / batch or monitoring occurrence		

Continuation Sheet 41 of 54

**New York State Department of Environmental Conservation
Air Permit Application Form**

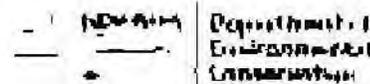

DEC ID											
3	-	3	3	5	6	-	0	0	1	3	6

Section IV - Emission Unit Information

Emission Unit Compliance Certification (continuation)									
Rule Citation									
Title	Type	Part	Subpart	Section	Subdivision	Paragraph	Subparagraph	Clause	Subclause
6	NYCRR	231	5	4					
<input checked="" type="checkbox"/> Applicable Federal Requirement						<input type="checkbox"/> State Only Requirement		<input type="checkbox"/> Capping	
Emission Unit	Emission Point	Process	Emission Source	CAS No.	Contaminant Name				
U-00005	EP005	P05		0NY210-00-0	Oxides of Nitrogen				
Monitoring Information									
<input type="checkbox"/> Continuous Emission Monitoring					<input type="checkbox"/> Monitoring of Process or Control Device Parameters as a Surrogate				
<input checked="" type="checkbox"/> Intermittent Emission Testing					<input type="checkbox"/> Work Practice Involving Specific Operations				
<input type="checkbox"/> Ambient Air Monitoring					<input type="checkbox"/> Record Keeping/Maintenance Procedures				
Description									
LAER is 0.857 pounds per million Btus. Will be achieved using good combustion controls. Emission testing to be performed upon request of the Department.									
Work Practice		Process Material				Reference Test Method			
Type	Code	Description				Method 7E			
Parameter		Manufacturer Name/Model No.							
Code	Description								
23	concentration								
Limit			Limit Units						
Upper	Lower	Code	Description						
0.857		7	pounds per million Btus						
Averaging Method			Monitoring Frequency			Reporting Requirements			
Code	Description		Code	Description		Code	Description		
08	1-hour average		14	as required		01	once / batch or monitoring occurrence		

**New York State Department of Environmental Conservation
Air Permit Application Form**

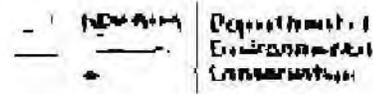

DEC ID											
3	-	3	3	5	6	-	0	0	1	3	6

Section IV - Emission Unit Information

Emission Unit Compliance Certification (continuation)									
Rule Citation									
Title	Type	Part	Subpart	Section	Subdivision	Paragraph	Subparagraph	Clause	Subclause
6	NYCRR	231	5	4					
<input checked="" type="checkbox"/> Applicable Federal Requirement						<input type="checkbox"/> State Only Requirement		<input type="checkbox"/> Capping	
Emission Unit	Emission Point	Process	Emission Source	CAS No.	Contaminant Name				
U-00005	EP005	P05		0NY998-00-0	VOC				
Monitoring Information									
<input type="checkbox"/> Continuous Emission Monitoring					<input type="checkbox"/> Monitoring of Process or Control Device Parameters as a Surrogate				
<input checked="" type="checkbox"/> Intermittent Emission Testing					<input type="checkbox"/> Work Practice Involving Specific Operations				
<input type="checkbox"/> Ambient Air Monitoring					<input type="checkbox"/> Record Keeping/Maintenance Procedures				
Description									
LAER is 0.3612 lb/mmBtu. Will be achieved using good combustion controls. Emission testing to be performed upon request of the Department.									
Work Practice		Process Material				Reference Test Method			
Type	Code	Description				Method 25A			
Parameter		Manufacturer Name/Model No.							
Code	Description								
23	concentration								
Limit			Limit Units						
Upper	Lower	Code	Description						
0.3612		7	pounds per million Btus						
Averaging Method			Monitoring Frequency			Reporting Requirements			
Code	Description		Code	Description		Code	Description		
08	1-hour average		14	as required		01	once / batch or monitoring occurrence		

**New York State Department of Environmental Conservation
Air Permit Application Form**

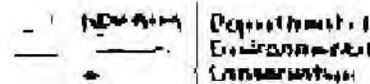

DEC ID											
3	-	3	3	5	6	-	0	0	1	3	6

Section IV - Emission Unit Information

Emission Unit Compliance Certification (continuation)									
Rule Citation									
Title	Type	Part	Subpart	Section	Subdivision	Paragraph	Subparagraph	Clause	Subclause
6	NYCRR	231	7	6					
<input checked="" type="checkbox"/> Applicable Federal Requirement						<input type="checkbox"/> State Only Requirement		<input type="checkbox"/> Capping	
Emission Unit	Emission Point	Process	Emission Source	CAS No.	Contaminant Name				
U-00005	EP005	P05		000630-08-0	CARBON MONOXIDE				
Monitoring Information									
<input type="checkbox"/> Continuous Emission Monitoring					<input type="checkbox"/> Monitoring of Process or Control Device Parameters as a Surrogate				
<input checked="" type="checkbox"/> Intermittent Emission Testing					<input type="checkbox"/> Work Practice Involving Specific Operations				
<input type="checkbox"/> Ambient Air Monitoring					<input type="checkbox"/> Record Keeping/Maintenance Procedures				
Description									
BACT is 0.75 lbs/mmBtus. Will be achieved using good combustion controls. Emission testing to be performed at the request of the Department.									
Work Practice		Process Material				Reference Test Method			
Type	Code	Description				Method 10			
Parameter		Manufacturer Name/Model No.							
Code	Description								
23	concentration								
Limit			Limit Units						
Upper	Lower	Code	Description						
0.75		7	pounds per million Btus						
Averaging Method		Monitoring Frequency		Reporting Requirements					
Code	Description	Code	Description	Code	Description				
08	1-hour average	14	as required	01	once / batch or monitoring occurrence				

**New York State Department of Environmental Conservation
Air Permit Application Form**

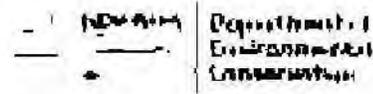

DEC ID											
3	-	3	3	5	6	-	0	0	1	3	6

Section IV - Emission Unit Information

Emission Unit Compliance Certification (continuation)										
Rule Citation										
Title	Type	Part	Subpart	Section	Subdivision	Paragraph	Subparagraph	Clause	Subclause	
6	NYCRR	231	7	6						
<input checked="" type="checkbox"/> Applicable Federal Requirement					<input type="checkbox"/> State Only Requirement			<input type="checkbox"/> Capping		
Emission Unit	Emission Point	Process	Emission Source	CAS No.		Contaminant Name				
U-00005	EP005	P05		0NY075-00-0, 0NY075-00-5		PARTICULATES, PM-10				
Monitoring Information										
<input type="checkbox"/> Continuous Emission Monitoring					<input type="checkbox"/> Monitoring of Process or Control Device Parameters as a Surrogate					
<input checked="" type="checkbox"/> Intermittent Emission Testing					<input type="checkbox"/> Work Practice Involving Specific Operations					
<input type="checkbox"/> Ambient Air Monitoring					<input type="checkbox"/> Record Keeping/Maintenance Procedures					
Description										
BACT is 0.043 lb/mmBtus. Will be achieved using low sulfur fuel. Emission testing to be performed at the request of the Department.										
Work Practice		Process Material				Reference Test Method				
Type	Code	Description								
						Method 201/201A and 202				
		Parameter				Manufacturer Name/Model No.				
Code	Description									
23	concentration									
Limit			Limit Units							
Upper	Lower	Code	Description							
0.043		7	pounds per million Btus							
Averaging Method			Monitoring Frequency			Reporting Requirements				
Code	Description		Code	Description		Code	Description			
08	1-hour average		14	as required		01	once / batch or monitoring occurrence			

**New York State Department of Environmental Conservation
Air Permit Application Form**

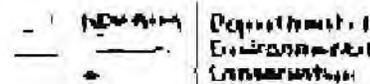

DEC ID											
3	-	3	3	5	6	-	0	0	1	3	6

Section IV - Emission Unit Information

Emission Unit Compliance Certification (continuation)									
Rule Citation									
Title	Type	Part	Subpart	Section	Subdivision	Paragraph	Subparagraph	Clause	Subclause
6	NYCRR	231	7	6					
<input checked="" type="checkbox"/> Applicable Federal Requirement						<input type="checkbox"/> State Only Requirement		<input type="checkbox"/> Capping	
Emission Unit	Emission Point	Process	Emission Source	CAS No.	Contaminant Name				
U-00005	EP005	P05		007446-09-5	SULFUR DIOXIDE				
Monitoring Information									
<input type="checkbox"/> Continuous Emission Monitoring					<input type="checkbox"/> Monitoring of Process or Control Device Parameters as a Surrogate				
<input checked="" type="checkbox"/> Intermittent Emission Testing					<input type="checkbox"/> Work Practice Involving Specific Operations				
<input type="checkbox"/> Ambient Air Monitoring					<input type="checkbox"/> Record Keeping/Maintenance Procedures				
Description									
BACT is 0.0014 lb/mmBtu. Will be achieved using low sulfur fuel. Emission testing to be performed at the request of the Department.									
Work Practice		Process Material				Reference Test Method			
Type	Code	Description				EPA approved methods			
Parameter		Manufacturer Name/Model No.							
Code	Description								
23	concentration								
Limit			Limit Units						
Upper	Lower	Code	Description						
0.0014		7	pounds per million Btus						
Averaging Method			Monitoring Frequency			Reporting Requirements			
Code	Description		Code	Description		Code	Description		
08	1-hour average		14	as required		01	once / batch or monitoring occurrence		

**New York State Department of Environmental Conservation
Air Permit Application Form**

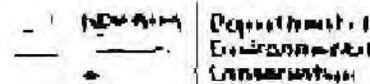

DEC ID											
3	-	3	3	5	6	-	0	0	1	3	6

Section IV - Emission Unit Information

Emission Unit Compliance Certification (continuation)									
Rule Citation									
Title	Type	Part	Subpart	Section	Subdivision	Paragraph	Subparagraph	Clause	Subclause
6	NYCRR	231	7	6					
<input checked="" type="checkbox"/> Applicable Federal Requirement						<input type="checkbox"/> State Only Requirement		<input type="checkbox"/> Capping	
Emission Unit	Emission Point	Process	Emission Source	CAS No.	Contaminant Name				
U-00005	EP005	P05		007664-93-9	SULFURIC ACID				
Monitoring Information									
<input type="checkbox"/> Continuous Emission Monitoring			<input type="checkbox"/> Monitoring of Process or Control Device Parameters as a Surrogate						
<input checked="" type="checkbox"/> Intermittent Emission Testing			<input type="checkbox"/> Work Practice Involving Specific Operations						
<input type="checkbox"/> Ambient Air Monitoring			<input type="checkbox"/> Record Keeping/Maintenance Procedures						
Description									
BACT is 0.0003 lb/mmBtu. Will be achieved using low sulfur fuel. Emission testing to be performed at the request of the Department.									
Work Practice		Process Material				Reference Test Method			
Type	Code	Description				EPA approved methods			
Parameter		Manufacturer Name/Model No.							
Code	Description								
23	concentration								
Limit			Limit Units						
Upper	Lower	Code	Description						
0.00003		7	pounds per million Btus						
Averaging Method		Monitoring Frequency		Reporting Requirements					
Code	Description	Code	Description	Code	Description				
08	1-hour average	14	as required	01	once / batch or monitoring occurrence				

New York State Department of Environmental Conservation
Air Permit Application Form

Department of
 Environmental
 Conservation

DEC ID											
3	-	3	3	5	6	-	0	0	1	3	6

Section IV - Emission Unit Information

Emission Unit Compliance Certification (continuation)									
Rule Citation									
Title	Type	Part	Subpart	Section	Subdivision	Paragraph	Subparagraph	Clause	Subclause
6	NYCRR	231	5	4					
<input checked="" type="checkbox"/> Applicable Federal Requirement						<input type="checkbox"/> State Only Requirement		<input type="checkbox"/> Capping	
Emission Unit	Emission Point	Process	Emission Source	CAS No.	Contaminant Name				
U-00006	EP006	P06		0NY210-00-0	Oxides of Nitrogen				
Monitoring Information									
<input type="checkbox"/> Continuous Emission Monitoring			<input type="checkbox"/> Monitoring of Process or Control Device Parameters as a Surrogate						
<input checked="" type="checkbox"/> Intermittent Emission Testing			<input type="checkbox"/> Work Practice Involving Specific Operations						
<input type="checkbox"/> Ambient Air Monitoring			<input type="checkbox"/> Record Keeping/Maintenance Procedures						
Description									
LAER is 0.058 pounds per million Btus for each individual gas heater. Will be achieved using forced draft low NOx Burner. Emission testing to be performed upon request of the Department.									
Work Practice		Process Material				Reference Test Method			
Type	Code	Description				Method 7E			
Parameter		Manufacturer Name/Model No.							
Code	Description								
23	concentration								
Limit			Limit Units						
Upper	Lower	Code	Description						
0.058		7	pounds per million Btus						
Averaging Method			Monitoring Frequency			Reporting Requirements			
Code	Description		Code	Description		Code	Description		
08	1-hour average		14	as required		01	once / batch or monitoring occurrence		

Continuation Sheet 48 of 54

**New York State Department of Environmental Conservation
Air Permit Application Form**

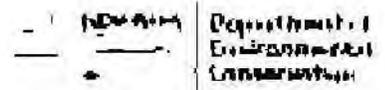

DEC ID											
3	-	3	3	5	6	-	0	0	1	3	6

Section IV - Emission Unit Information

Emission Unit Compliance Certification (continuation)									
Rule Citation									
Title	Type	Part	Subpart	Section	Subdivision	Paragraph	Subparagraph	Clause	Subclause
6	NYCRR	231	5	4					
<input checked="" type="checkbox"/> Applicable Federal Requirement						<input type="checkbox"/> State Only Requirement		<input type="checkbox"/> Capping	
Emission Unit	Emission Point	Process	Emission Source	CAS No.	Contaminant Name				
U-00006	EP006	P06		0NY998-00-0	VOC				
Monitoring Information									
<input type="checkbox"/> Continuous Emission Monitoring					<input type="checkbox"/> Monitoring of Process or Control Device Parameters as a Surrogate				
<input checked="" type="checkbox"/> Intermittent Emission Testing					<input type="checkbox"/> Work Practice Involving Specific Operations				
<input type="checkbox"/> Ambient Air Monitoring					<input type="checkbox"/> Record Keeping/Maintenance Procedures				
Description									
LAER is 0.011 lb/mmBtu. Will be achieved using good combustion controls. Emission testing to be performed upon request of the Department.									
Work Practice		Process Material				Reference Test Method			
Type	Code	Description				Method 25A			
Parameter		Manufacturer Name/Model No.							
Code	Description								
23	concentration								
Limit			Limit Units						
Upper	Lower	Code	Description						
0.011		7	pounds per million Btus						
Averaging Method			Monitoring Frequency			Reporting Requirements			
Code	Description		Code	Description		Code	Description		
08	1-hour average		14	as required		01	once / batch or monitoring occurrence		

**New York State Department of Environmental Conservation
Air Permit Application Form**

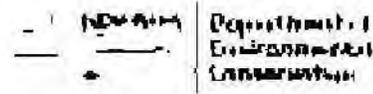

DEC ID											
3	-	3	3	5	6	-	0	0	1	3	6

Section IV - Emission Unit Information

Emission Unit Compliance Certification (continuation)									
Rule Citation									
Title	Type	Part	Subpart	Section	Subdivision	Paragraph	Subparagraph	Clause	Subclause
6	NYCRR	231	7	6					
<input checked="" type="checkbox"/> Applicable Federal Requirement						<input type="checkbox"/> State Only Requirement		<input type="checkbox"/> Capping	
Emission Unit	Emission Point	Process	Emission Source	CAS No.	Contaminant Name				
U-00006	EP006	P06		007664-93-9	SULFURIC ACID				
Monitoring Information									
<input type="checkbox"/> Continuous Emission Monitoring					<input type="checkbox"/> Monitoring of Process or Control Device Parameters as a Surrogate				
<input checked="" type="checkbox"/> Intermittent Emission Testing					<input type="checkbox"/> Work Practice Involving Specific Operations				
<input type="checkbox"/> Ambient Air Monitoring					<input type="checkbox"/> Record Keeping/Maintenance Procedures				
Description									
BACT is 0.0002 lb/mmBtu. Will be achieved using low sulfur fuel. Emission testing to be performed at the request of the Department.									
Work Practice		Process Material				Reference Test Method			
Type	Code	Description				EPA approved methods			
Parameter		Manufacturer Name/Model No.							
Code	Description								
23	concentration								
Limit			Limit Units						
Upper	Lower	Code	Description						
0.0002		7	pounds per million Btus						
Averaging Method		Monitoring Frequency		Reporting Requirements					
Code	Description	Code	Description	Code	Description				
08	1-hour average	14	as required	01	once / batch or monitoring occurrence				

New York State Department of Environmental Conservation
Air Permit Application Form

Department of
Environmental
Conservation

DEC ID											
3	-	3	3	5	6	-	0	0	1	3	6

Section IV - Emission Unit Information

Emission Unit Compliance Certification (continuation)										
Rule Citation										
Title	Type	Part	Subpart	Section	Subdivision	Paragraph	Subparagraph	Clause	Subclause	
6	NYCRR	231	7	6						
<input checked="" type="checkbox"/> Applicable Federal Requirement					<input type="checkbox"/> State Only Requirement			<input type="checkbox"/> Capping		
Emission Unit	Emission Point	Process	Emission Source	CAS No.	Contaminant Name					
U-00006	EP006	P06		000630-08-0	CARBON MONOXIDE					
Monitoring Information										
<input type="checkbox"/> Continuous Emission Monitoring					<input type="checkbox"/> Monitoring of Process or Control Device Parameters as a Surrogate					
<input checked="" type="checkbox"/> Intermittent Emission Testing					<input type="checkbox"/> Work Practice Involving Specific Operations					
<input type="checkbox"/> Ambient Air Monitoring					<input type="checkbox"/> Record Keeping/Maintenance Procedures					
Description										
BACT is 0.084 lbs/mmBtus. Will be achieved using good combustion controls. Emission testing to be performed at the request of the Department.										
Work Practice		Process Material				Reference Test Method				
Type	Code	Description				Method 10				
Parameter		Manufacturer Name/Model No.								
Code	Description									
23	concentration									
Limit			Limit Units							
Upper	Lower	Code	Description							
0.084		7	pounds per million Btus							
Averaging Method			Monitoring Frequency			Reporting Requirements				
Code	Description		Code	Description		Code	Description			
08	1-hour average		14	as required		01	once / batch or monitoring occurrence			

Continuation Sheet 51 of 54

New York State Department of Environmental Conservation
Air Permit Application Form

Department of
 Environmental
 Conservation

DEC ID											
3	-	3	3	5	6	-	0	0	1	3	6

Section IV - Emission Unit Information

Emission Unit Compliance Certification (continuation)										
Rule Citation										
Title	Type	Part	Subpart	Section	Subdivision	Paragraph	Subparagraph	Clause	Subclause	
6	NYCRR	231	7	6						
<input checked="" type="checkbox"/> Applicable Federal Requirement					<input type="checkbox"/> State Only Requirement			<input type="checkbox"/> Capping		
Emission Unit	Emission Point	Process	Emission Source	CAS No.		Contaminant Name				
U-00006	EP006	P06		0NY075-00-0, 0NY075-00-5		PARTICULATES, PM-10				
Monitoring Information										
<input type="checkbox"/> Continuous Emission Monitoring					<input type="checkbox"/> Monitoring of Process or Control Device Parameters as a Surrogate					
<input checked="" type="checkbox"/> Intermittent Emission Testing					<input type="checkbox"/> Work Practice Involving Specific Operations					
<input type="checkbox"/> Ambient Air Monitoring					<input type="checkbox"/> Record Keeping/Maintenance Procedures					
Description										
BACT is 0.0076 lb/mmBtus.. Will be achieved using low sulfur fuel. Emission testing to be performed at the request of the Department.										
Work Practice		Process Material				Reference Test Method				
Type	Code	Description				Reference Test Method				
						Method 201/201A and 202				
Parameter		Manufacturer Name/Model No.								
Code	Description				Manufacturer Name/Model No.					
23	concentration									
Limit			Limit Units							
Upper	Lower	Code	Description							
0.0076		7	pounds per million Btus							
Averaging Method			Monitoring Frequency			Reporting Requirements				
Code	Description		Code	Description		Code	Description			
08	1-hour average		14	as required		01	once / batch or monitoring occurrence			

Continuation Sheet 52 of 54

New York State Department of Environmental Conservation
Air Permit Application Form

Department of
 Environmental
 Conservation

DEC ID											
3	-	3	3	5	6	-	0	0	1	3	6

Section IV - Emission Unit Information

Emission Unit Compliance Certification (continuation)									
Rule Citation									
Title	Type	Part	Subpart	Section	Subdivision	Paragraph	Subparagraph	Clause	Subclause
6	NYCRR	231	7	6					
<input checked="" type="checkbox"/> Applicable Federal Requirement						<input type="checkbox"/> State Only Requirement		<input type="checkbox"/> Capping	
Emission Unit	Emission Point	Process	Emission Source	CAS No.	Contaminant Name				
U-00006	EP006	P06		007446-09-5	SULFUR DIOXIDE				
Monitoring Information									
<input type="checkbox"/> Continuous Emission Monitoring					<input type="checkbox"/> Monitoring of Process or Control Device Parameters as a Surrogate				
<input checked="" type="checkbox"/> Intermittent Emission Testing					<input type="checkbox"/> Work Practice Involving Specific Operations				
<input type="checkbox"/> Ambient Air Monitoring					<input type="checkbox"/> Record Keeping/Maintenance Procedures				
Description									
BACT is 0.0022 lb/mmBtu. Will be achieved using low sulfur fuel. Emission testing to be performed at the request of the Department.									
Work Practice		Process Material				Reference Test Method			
Type	Code	Description				EPA approved methods			
Parameter		Manufacturer Name/Model No.							
Code	Description								
23	concentration								
Limit			Limit Units						
Upper	Lower	Code	Description						
0.0022		7	pounds per million Btus						
Averaging Method			Monitoring Frequency			Reporting Requirements			
Code	Description		Code	Description		Code	Description		
08	1-hour average		14	as required		01	once / batch or monitoring occurrence		

Continuation Sheet 53 of 54

New York State Department of Environmental Conservation

Air Permit Application Form

 Department of
Environmental
Conservation

DEC ID											
3	-	3	3	5	6	-	0	0	1	3	6

Section IV - Emission Unit Information

Emission Unit Compliance Certification (continuation)																																																	
Rule Citation																																																	
Title	Type	Part	Subpart	Section	Subdivision	Paragraph	Subparagraph	Clause	Subclause																																								
6	NYCRR	201	7																																														
<input checked="" type="checkbox"/> Applicable Federal Requirement						<input type="checkbox"/> State Only Requirement		<input type="checkbox"/> Capping																																									
Emission Unit	Emission Point	Process	Emission Source	CAS No.	Contaminant Name																																												
				0NY075-02-5	PM 2.5																																												
Monitoring Information																																																	
<input type="checkbox"/> Continuous Emission Monitoring			<input type="checkbox"/> Monitoring of Process or Control Device Parameters as a Surrogate																																														
<input type="checkbox"/> Intermittent Emission Testing			<input checked="" type="checkbox"/> Work Practice Involving Specific Operations																																														
<input type="checkbox"/> Ambient Air Monitoring			<input type="checkbox"/> Record Keeping/Maintenance Procedures																																														
Description																																																	
<p>Monthly facility-wide emissions of PM-2.5 will be calculated as the sum of monthly PM-2.5 emissions from individual emission units or source groups. Emissions will be calculated based on heat input (or, equivalently, from fuel use) and emission factors as described below. Annual facility-wide emissions will then be determined at the end of each month on a rolling 12-month basis in order to demonstrate compliance with the 95 ton per year cap.</p> <table border="1"> <thead> <tr> <th>Unit Op Load</th><th>Fuel</th><th>Grp</th><th>Emission Factor</th></tr> </thead> <tbody> <tr> <td>CT only > 80%</td><td>Gas</td><td>1</td><td>0.0056</td></tr> <tr> <td>CT only < 80%</td><td>Gas</td><td>2</td><td>0.0073</td></tr> <tr> <td>CT + DB > 80%</td><td>Gas</td><td>3</td><td>0.0064</td></tr> <tr> <td>CT only > 85%</td><td>Oil</td><td>4</td><td>0.0247</td></tr> <tr> <td>CT only < 85%</td><td>Oil</td><td>5</td><td>0.0368</td></tr> <tr> <td>Aux Boiler All</td><td>Gas</td><td>6</td><td>0.0063</td></tr> <tr> <td>Gas Heater All</td><td>Gas</td><td>7</td><td>0.0076</td></tr> <tr> <td>EDG All</td><td>Oil</td><td>8</td><td>0.0091</td></tr> <tr> <td>EFP All</td><td>Oil</td><td>9</td><td>0.0429</td></tr> </tbody> </table> <p>In cases where fuel use (gallons of oil or SCF of gas) for a source group is monitored directly rather than heat input, the equivalent heat input will be determined by multiplying the monthly fuel usage for the source group by the corresponding fuel heating value (mmBtu/gallon or mmBtu/scf), using the higher heating. In cases where fuel use (gallons of oil or standard cubic feet of gas) for a source group is monitored directly rather than heat input, the equivalent heat input will be determined by multiplying the monthly fuel usage for the source group by the corresponding fuel heating value (mmBtu/gallon or mmBtu/scf), using the higher heating value basis for fuel.</p>										Unit Op Load	Fuel	Grp	Emission Factor	CT only > 80%	Gas	1	0.0056	CT only < 80%	Gas	2	0.0073	CT + DB > 80%	Gas	3	0.0064	CT only > 85%	Oil	4	0.0247	CT only < 85%	Oil	5	0.0368	Aux Boiler All	Gas	6	0.0063	Gas Heater All	Gas	7	0.0076	EDG All	Oil	8	0.0091	EFP All	Oil	9	0.0429
Unit Op Load	Fuel	Grp	Emission Factor																																														
CT only > 80%	Gas	1	0.0056																																														
CT only < 80%	Gas	2	0.0073																																														
CT + DB > 80%	Gas	3	0.0064																																														
CT only > 85%	Oil	4	0.0247																																														
CT only < 85%	Oil	5	0.0368																																														
Aux Boiler All	Gas	6	0.0063																																														
Gas Heater All	Gas	7	0.0076																																														
EDG All	Oil	8	0.0091																																														
EFP All	Oil	9	0.0429																																														
Work Practice		Process Material				Reference Test Method																																											
Type	Code	Description																																															
04	318	Fuel																																															
Parameter		Manufacturer Name/Model No.																																															
Code	Description																																																
38	Heat Input																																																
Limit			Limit Units																																														
Upper	Lower	Code	Description																																														
95		38	tons per year																																														
Averaging Method			Monitoring Frequency			Reporting Requirements																																											
Code	Description		Code	Description		Code	Description																																										
17	annual maximum rolled monthly		01	CONTINUOUS		15	ANNUALLY (CALENDAR)																																										

Continuation Sheet 54 of 54

**New York State Department of Environmental Conservation
Air Permit Application**



Department of Environmental Conservation

DEC ID											
3	-	3	3	5	6	-	0	0	1	3	6

Process Information										Continuation Sheet(s)				
Emission Unit	U	-	0	0	0	0	0	4			Process	P	0	4

Process Description

Process P04 represents the emergency generator firing on diesel fuel.

Source Classification Code (SCC)	Total Throughput		Throughput Quantity Units	
	Quantity/Hr	Quantity/Yr	Code	Description
2-01-002-01	110.4	36,300	0045	gallons

Confidential * Operating at Maximum Capacity	Operating Schedule		Building	Floor/Location
	Hours/Day	Days/Year		
	500 Hours			

Emission Point Identifier(s)						
EG01						

Emission Source/Control Identifier(s)						

Emission Unit	-										Process			
---------------	---	--	--	--	--	--	--	--	--	--	---------	--	--	--

Process Description

Source Classification Code (SCC)	Total Throughput		Throughput Quantity Units	
	Quantity/Hr	Quantity/Yr	Code	Description

Confidential Operating at Maximum Capacity	Operating Schedule		Building	Floor/Location
	Hours/Day	Days/Year		

Emission Point Identifier(s)						

Emission Source/Control Identifier(s)						

**New York State Department of Environmental Conservation
Air Permit Application**



Department of Environmental Conservation

DEC ID											
3	-	3	3	5	6	-	0	0	1	3	6

Process Information										* Continuation Sheet(s)				
Emission Unit	U	-	0	0	0	0	0	6			Process	P	0	6

Process Description

Process P06 represents one dew point heater with two fuel gas burners operating on natural gas.

Source Classification Code (SCC)	Total Throughput		Throughput Quantity Units	
	Quantity/Hr	Quantity/Yr	Code	Description
2-01-002-01	5.02	78,489.6	0104	million Btu heat input

Confidential * Operating at Maximum Capacity	Operating Schedule		Building	Floor/Location
	Hours/Day	Days/Year		
	24	365		

Emission Point Identifier(s)						
FGH1						

Emission Source/Control Identifier(s)						

Emission Unit	-									Process			
---------------	---	--	--	--	--	--	--	--	--	---------	--	--	--

Process Description

Source Classification Code (SCC)	Total Throughput		Throughput Quantity Units	
	Quantity/Hr	Quantity/Yr	Code	Description

Confidential Operating at Maximum Capacity	Operating Schedule		Building	Floor/Location
	Hours/Day	Days/Year		

Emission Point Identifier(s)						

Emission Source/Control Identifier(s)						

**New York State Department of Environmental Conservation
Air Permit Application**



Department of Environmental Conservation

DEC ID											
3	-	3	3	5	6	-	0	0	1	3	6

Process Information										* Continuation Sheet(s)				
Emission Unit	U	-	0	0	0	0	0	6			Process	P	0	6

Process Description

Process P06 represents one 9.0 mmBtu/hr dew point heater with two fuel gas burners operating on natural gas.

Source Classification Code (SCC)	Total Throughput		Throughput Quantity Units	
	Quantity/Hr	Quantity/Yr	Code	Description
2-01-002-01	5.02	78,489.6	0104	million Btu heat input

Confidential * Operating at Maximum Capacity	Operating Schedule		Building	Floor/Location
	Hours/Day	Days/Year		
	24	365		

Emission Point Identifier(s)					
FGH1					

Emission Source/Control Identifier(s)					

Emission Unit	-									Process			
---------------	---	--	--	--	--	--	--	--	--	---------	--	--	--

Process Description

Source Classification Code (SCC)	Total Throughput		Throughput Quantity Units	
	Quantity/Hr	Quantity/Yr	Code	Description

Confidential Operating at Maximum Capacity	Operating Schedule		Building	Floor/Location
	Hours/Day	Days/Year		

Emission Point Identifier(s)					

Emission Source/Control Identifier(s)					

**New York State Department of Environmental Conservation
Air Permit Application**



Department of
Environmental
Conservation

DEC ID											
3	-	3	3	5	6	-	0	0	1	3	6

Section IV - Emission Unit Information

Emission Unit Description											Continuation Sheet(s)
Emission Unit	U	-	0	0	0	0	0	7			
Five EngA Space Heaters Model: DGP-500											

Building Information					Continuation Sheet(s)	
Building ID	Building Name			Length (ft)	Width (ft)	Orientation
GEN01	Generation Building			300	260	North
GEN02	Generation Building			300	260	North

Emission Unit		Emission Unit Emissions Summary				Continuation Sheet(s)
U	-	0	0	0	0	7
CAS Number		Contaminant Name				
ERP (lbs/yr)	Potential to Emit		Actual Emissions			
	(lbs/hr)	(lbs/yr)	(lbs/hr)	(lbs/yr)		
CAS Number		Contaminant Name				
ERP (lbs/yr)	Potential to Emit		Actual Emissions			
	(lbs/hr)	(lbs/yr)	(lbs/hr)	(lbs/yr)		
CAS Number		Contaminant Name				
ERP (lbs/yr)	Potential to Emit		Actual Emissions			
	(lbs/hr)	(lbs/yr)	(lbs/hr)	(lbs/yr)		
CAS Number		Contaminant Name				
ERP (lbs/yr)	Potential to Emit		Actual Emissions			
	(lbs/hr)	(lbs/yr)	(lbs/hr)	(lbs/yr)		

**New York State Department of Environmental Conservation
Air Permit Application**



Department of
Environmental
Conservation

DEC ID											
3	-	3	3	5	6	-	0	0	1	3	6

Section IV - Emission Unit Information

Emission Unit Description											Continuation Sheet(s)
Emission Unit	U	-	0	0	0	0	0	8			
Aggreko Mobile Generator Model: NHC20											

Building Information				Continuation Sheet(s)
Building ID	Building Name	Length (ft)	Width (ft)	Orientation
NONE	Located Outdoor			

Emission Unit		Emission Unit Emissions Summary				Continuation Sheet(s)
U	-	0	0	0	0	8
CAS Number		Contaminant Name				
ERP (lbs/yr)	Potential to Emit		Actual Emissions			
	(lbs/hr)	(lbs/yr)	(lbs/hr)	(lbs/yr)		
CAS Number		Contaminant Name				
ERP (lbs/yr)	Potential to Emit		Actual Emissions			
	(lbs/hr)	(lbs/yr)	(lbs/hr)	(lbs/yr)		
CAS Number		Contaminant Name				
ERP (lbs/yr)	Potential to Emit		Actual Emissions			
	(lbs/hr)	(lbs/yr)	(lbs/hr)	(lbs/yr)		
CAS Number		Contaminant Name				
ERP (lbs/yr)	Potential to Emit		Actual Emissions			
	(lbs/hr)	(lbs/yr)	(lbs/hr)	(lbs/yr)		



CPV Valley Energy Center
50 Braintree Hill Office Park
Suite 300
Braintree, MA 02184

ATTACHMENT 2

Title IV Acid Rain Application

STEP 3

Permit Requirements

Read the standard requirements.

- (1) The designated representative of each affected source and each affected unit at the source shall:
 - (i) Submit a complete Acid Rain permit application (including a compliance plan) under 40 CFR part 72 in accordance with the deadlines specified in 40 CFR 72.30; and
 - (ii) Submit in a timely manner any supplemental information that the permitting authority determines is necessary in order to review an Acid Rain permit application and issue or deny an Acid Rain permit;
- (2) The owners and operators of each affected source and each affected unit at the source shall:
 - (i) Operate the unit in compliance with a complete Acid Rain permit application or a superseding Acid Rain permit issued by the permitting authority; and
 - (ii) Have an Acid Rain Permit.

Monitoring Requirements

- (1) The owners and operators and, to the extent applicable, designated representative of each affected source and each affected unit at the source shall comply with the monitoring requirements as provided in 40 CFR part 75.
- (2) The emissions measurements recorded and reported in accordance with 40 CFR part 75 shall be used to determine compliance by the source or unit, as appropriate, with the Acid Rain emissions limitations and emissions reduction requirements for sulfur dioxide and nitrogen oxides under the Acid Rain Program.
- (3) The requirements of 40 CFR part 75 shall not affect the responsibility of the owners and operators to monitor emissions of other pollutants or other emissions characteristics at the unit under other applicable requirements of the Act and other provisions of the operating permit for the source.

Sulfur Dioxide Requirements

- (1) The owners and operators of each source and each affected unit at the source shall:
 - (i) Hold allowances, as of the allowance transfer deadline, in the source's compliance account (after deductions under 40 CFR 73.34(c)), not less than the total annual emissions of sulfur dioxide for the previous calendar year from the affected units at the source; and
 - (ii) Comply with the applicable Acid Rain emissions limitations for sulfur dioxide.
- (2) Each ton of sulfur dioxide emitted in excess of the Acid Rain emissions limitations for sulfur dioxide shall constitute a separate violation of the Act.
- (3) An affected unit shall be subject to the requirements under paragraph (1) of the sulfur dioxide requirements as follows:
 - (i) Starting January 1, 2000, an affected unit under 40 CFR 72.6(a)(2); or
 - (ii) Starting on the later of January 1, 2000 or the deadline for monitor certification under 40 CFR part 75, an affected unit under 40 CFR 72.6(a)(3).
- (4) Allowances shall be held in, deducted from, or transferred among Allowance Tracking System accounts in accordance with the Acid Rain Program.
- (5) An allowance shall not be deducted in order to comply with the requirements under paragraph (1) of the sulfur dioxide requirements prior to the calendar year for which the allowance was allocated.
- (6) An allowance allocated by the Administrator under the Acid Rain Program is a limited authorization to emit sulfur dioxide in accordance with the Acid Rain Program. No provision of the Acid Rain Program, the Acid Rain permit application, the Acid Rain permit, or an exemption under 40 CFR 72.7 or 72.8 and no provision of law shall be construed to limit the authority of the United States to terminate or limit such authorization.
- (7) An allowance allocated by the Administrator under the Acid Rain Program does not constitute a property right.

Nitrogen Oxides Requirements

The owners and operators of the source and each affected unit at the source shall comply with the applicable Acid Rain emissions limitation for nitrogen oxides.

STEP 3, Cont'd.

Excess Emissions Requirements

- (1) The designated representative of an affected source that has excess emissions in any calendar year shall submit a proposed offset plan, as required under 40 CFR part 77.
- (2) The owners and operators of an affected source that has excess emissions in any calendar year shall:
 - (i) Pay without demand the penalty required, and pay upon demand the interest on that penalty, as required by 40 CFR part 77; and
 - (ii) Comply with the terms of an approved offset plan, as required by 40 CFR part 77.

Recordkeeping and Reporting Requirements

- (1) Unless otherwise provided, the owners and operators of the source and each affected unit at the source shall keep on site at the source each of the following documents for a period of 5 years from the date the document is created. This period may be extended for cause, at any time prior to the end of 5 years, in writing by the Administrator or permitting authority:
 - (i) The certificate of representation for the designated representative for the source and each affected unit at the source and all documents that demonstrate the truth of the statements in the certificate of representation, in accordance with 40 CFR 72.24; provided that the certificate and documents shall be retained on site at the source beyond such 5-year period until such documents are superseded because of the submission of a new certificate of representation changing the designated representative;
 - (ii) All emissions monitoring information, in accordance with 40 CFR part 75, provided that to the extent that 40 CFR part 75 provides for a 3-year period for recordkeeping, the 3-year period shall apply.
 - (iii) Copies of all reports, compliance certifications, and other submissions and all records made or required under the Acid Rain Program; and,
 - (iv) Copies of all documents used to complete an Acid Rain permit application and any other submission under the Acid Rain Program or to demonstrate compliance with the requirements of the Acid Rain Program.
- (2) The designated representative of an affected source and each affected unit at the source shall submit the reports and compliance certifications required under the Acid Rain Program, including those under 40 CFR part 72 subpart I and 40 CFR part 75.

Liability

- (1) Any person who knowingly violates any requirement or prohibition of the Acid Rain Program, a complete Acid Rain permit application, an Acid Rain permit, or an exemption under 40 CFR 72.7 or 72.8, including any requirement for the payment of any penalty owed to the United States, shall be subject to enforcement pursuant to section 113(c) of the Act.
- (2) Any person who knowingly makes a false, material statement in any record, submission, or report under the Acid Rain Program shall be subject to criminal enforcement pursuant to section 113(c) of the Act and 18 U.S.C. 1001.
- (3) No permit revision shall excuse any violation of the requirements of the Acid Rain Program that occurs prior to the date that the revision takes effect.
- (4) Each affected source and each affected unit shall meet the requirements of the Acid Rain Program.
- (5) Any provision of the Acid Rain Program that applies to an affected source (including a provision applicable to the designated representative of an affected source) shall also apply to the owners and operators of such source and of the affected units at the source.
- (6) Any provision of the Acid Rain Program that applies to an affected unit (including a provision applicable to the designated representative of an affected unit) shall also apply to the owners and operators of such unit.
- (7) Each violation of a provision of 40 CFR parts 72, 73, 74, 75, 76, 77, and 78 by an affected source or affected unit, or by an owner or operator or designated representative of such source or unit, shall be a separate violation of the Act.

STEP 3, Cont'd.

Effect on Other Authorities

No provision of the Acid Rain Program, an Acid Rain permit application, an Acid Rain permit, or an exemption under 40 CFR 72.7 or 72.8 shall be construed as:

- (1) Except as expressly provided in title IV of the Act, exempting or excluding the owners and operators and, to the extent applicable, the designated representative of an affected source or affected unit from compliance with any other provision of the Act, including the provisions of title I of the Act relating to applicable National Ambient Air Quality Standards or State Implementation Plans;
- (2) Limiting the number of allowances a source can hold; provided, that the number of allowances held by the source shall not affect the source's obligation to comply with any other provisions of the Act;
- (3) Requiring a change of any kind in any State law regulating electric utility rates and charges, affecting any State law regarding such State regulation, or limiting such State regulation, including any prudence review requirements under such State law;
- (4) Modifying the Federal Power Act or affecting the authority of the Federal Energy Regulatory Commission under the Federal Power Act; or,
- (5) Interfering with or impairing any program for competitive bidding for power supply in a State in which such program is established.

STEP 4

Certification

Read the certification statement, sign, and date.

I am authorized to make this submission on behalf of the owners and operators of the affected source or affected units for which the submission is made. I certify under penalty of law that I have personally examined, and am familiar with, the statements and information submitted in this document and all its attachments. Based on my inquiry of those individuals with primary responsibility for obtaining the information, I certify that the statements and information are to the best of my knowledge and belief true, accurate, and complete. I am aware that there are significant penalties for submitting false statements and information or omitting required statements and information, including the possibility of fine or imprisonment.

Name <u>Donald G. Atwood</u>	
Signature 	Date <u>08-24-2018</u>



CPV Valley Energy Center
50 Braintree Hill Office Park
Suite 300
Braintree, MA 02184

ATTACHMENT 3

Potential-to-Emit Table

**Appendix B: Table B-1
CPV Valley Energy Center
Combined Cycle Turbine Emissions
Natural Gas Firing**

SWP C5000F Combustion Turbine in Combined Cycle Mode

Operating Mode	50% Load					60% Load					70% Load					Startup Emissions			
	BASE	BASE	80%	80%	60%	BASE	BASE	80%	80%	60%	BASE	BASE	80%	80%	60%	BASE	BASE	80%	
Ambient Temp, °F	-	-	-	-	-	-	-	-	-	-	-	-	-	-	-	-	-	-	-
Fuel Type	On	On	On	On	On	On	On	On	On	On	On	On	On	On	On	On	On	On	On
Evaporative Cooler Operation (80% Efficiency)	Off	Off	Off	Off	Off	Off	Off	Off	Off	Off	Off	Off	Off	Off	Off	Off	Off	Off	Off
Combustion Turbine (CTG) Heat Input, mmBtu/hr (HHV)	2,234	2,234	2,083	1,859	1,998	1,998	1,998	1,854	1,364	1,855	1,855	1,855	1,855	1,669	1,243	1,354	1,354	1,354	
Duct Burner Operation	Off	On	Off	Off	On	On	Off	Off	Off	On	On	Off	Off	Off	Off	Off	Off	Off	Off
Duct Burner Heat Input, mmBtu/hr (HHV)	-	500.0	-	-	1,854	500.0	-	-	-	-	500.0	-	500.0	-	-	-	-	-	-
Combined Power Output of 2 CTGs @ STG, MW	669.6	669.6	428.8	349.5	649.3	649.3	604.9	401.8	306.2	653.2	649.7	653.2	649.7	325.8	270.8	-	-	-	
Controlled CTG and DB Pollutant Concentrations																			
NO _x	ppmv @ 15% O ₂	2.0	2.0	2.0	2.0	2.00	2.00	2.0	2.0	2.0	2.00	2.0	2.00	2.0	2.0	2.0	2.0	2.0	2.0
CO	ppmv @ 15% O ₂	2.0	3.3	2.0	2.0	2.66	3.44	2.0	2.0	2.0	3.90	2.0	3.55	2.0	2.0	2.0	2.0	2.0	2.0
VOC	ppmv @ 15% O ₂	0.7	1.6	0.7	0.7	1.12	1.67	0.7	0.7	0.7	1.92	0.7	1.77	0.7	0.7	0.7	0.7	0.7	0.7
NH ₃	ppmv @ 15% O ₂	5.0	5.0	5.0	5.0	5.0	5.0	5.0	5.0	5.0	5.0	5.0	5.0	5.0	5.0	5.0	5.0	5.0	5.0
Controlled CTG and DB Emission Factors, lb/mmBtu (HHV)																			
NO _x	0.0075	0.0093	0.0068	0.0074	0.0075	0.0075	0.0075	0.0067	0.0075	0.0075	0.0075	0.0075	0.0074	0.0073	0.0068	0.0075	-	-	-
CO	0.0046	0.0050	0.0041	0.0179	0.0059	0.0077	0.0046	0.004	0.0183	0.0078	0.0045	0.0077	0.0044	0.004	0.0183	-	-	-	-
VOC	0.0009	0.0025	0.0008	0.0027	0.0014	0.0021	0.0009	0.0008	0.0028	0.0022	0.0009	0.0022	0.0009	0.0008	0.0028	-	-	-	-
SO ₂	0.0002	0.0027	0.0002	0.0002	0.0002	0.0002	0.0002	0.0002	0.0002	0.0002	0.0002	0.0002	0.0002	0.0002	0.0002	0.0002	-	-	-
Sulfuric Acid Mist (H ₂ SO ₄)	0.0007	0.0008	0.0007	0.0007	0.0007	0.0007	0.0007	0.0007	0.0007	0.0007	0.0007	0.0007	0.0007	0.0007	0.0007	0.0007	-	-	-
PM ₁₀ (Filterables, condensables and sulfates)	0.0050	0.006	0.0047	0.0061	0.0055	0.0062	0.0059	0.0052	0.0068	0.0054	0.0052	0.0054	0.0052	0.0055	0.0055	0.0057	-	-	-
Controlled CTG and DB Stack Emissions, lb/hr																			
NO _x	1680	2080	1408	1144	1622	1904	1504	1256	1024	1702	1392	1752	1392	1144	936	3544	4096	3802	
CO	1020	2020	860	2780	129	1920	920	760	2500	1840	840	1820	820	700	2280	26905	33399	32978	
VOC	203	553	175	420	312	532	182	164	376	518	168	518	168	140	343	5307	5759	983	
SO ₂	487	599	494	338	476	545	436	406	297	513	404	513	404	368	271	-	-	-	
SO ₃	122	149	114	885	119	136	109	101	074	128	101	128	101	092	068	-	-	-	
NH ₃	1193	1193	1020	859	1089	1089	1089	937	802	990	990	959	959	846	726	-	-	-	
Sulfuric Acid Mist (H ₂ SO ₄)	149	182	139	104	146	157	133	124	09	157	124	157	124	113	83	-	-	-	
Ammonia Sulfates (NH ₄) ₂ SO ₄	201	246	187	140	196	225	180	167	123	212	167	212	167	152	112	-	-	-	
PM ₁₀ (Filterables and condensables)	910	1410	800	800	1015	1330	830	800	800	1300	800	1300	800	800	800	-	-	-	
PM ₁₀ (Filterables, condensables and sulfates)	1111	1655	987	940	1212	1555	1010	957	923	1512	957	1512	957	952	912	966	955	940	
Stack Parameters																			
Stack Diameter, m	579	579	579	579	579	579	579	579	579	579	579	579	579	579	579	579	579	579	579
Stack Diameter, ft	19.0	19.0	19.0	19.0	19.0	19.0	19.0	19.0	19.0	19.0	19.0	19.0	19.0	19.0	19.0	19.0	19.0	19.0	19.0
Exhaust Flow per Stack, lb/hr	4332	4353	3700	3143	3974	3988	3966	3407	2909	3688	3667	3698	3577	3116	2590	1464	1494	1494	
Exhaust Volume, acfm	1231680	123785	1,043,920	870,780	1,122,668	1,126,905	1,120,440	920,460	802,740	1,061,761	1,055,580	1,061,916	1,055,580	867,320	740,000	401,370	401,370	401,370	
Stack Exit Velocity, ft/s	72.4	72.8	61.3	9.2	66.0	66.2	65.9	55.9	47.2	62.4	62.1	62.4	62.1	9.0	43.5	23.6	23.6	23.6	
Stack Exit Velocity, m/s	22.1	22.2	18.7	1.56	20.1	20.2	20.1	17.0	14.4	19.0	18.9	19.0	18.9	1.55	13.3	7.2	7.2	7.2	
Stack Exit Temperature, °F	195	196	182	179	182	182	189	178	175	183	183	196	196	175	173	113.5	113.5	113.5	
Stack Exit Temperature, deg K	357.7	357.7	328.5	326.8	326.5	326.5	326.4	325.3	325.2	327.0	327.0	328.3	328.3	326.6	325.5	318.4	318.4	318.4	
Emission Rates, g/s																			
NO _x	2.117	2.621	1.774	1.441	2.082	2.399	1.895	1.583	1.290	2.258	1.754	2.208	1.704	1.441	1.179	4.466	5160	4791	
CO	1.285	2.585	1.084	3.903	1.626	2.49	1.599	0.998	3.150	2.318	1.098	2.293	1.033	0.888	2.873	33900	42028	41494	
VOC	0.295	0.529	0.221	0.299	0.321	0.570	0.229	0.194	0.476	0.551	0.212	0.551	0.212	0.175	0.412	6.687	7252	6511	
SO ₂	0.614	0.729	0.572	0.466	0.600	0.686	0.491	0.475	0.547	0.930	0.547	0.930	0.547	0.504	0.34	-	-	-	
Sulfuric Acid Mist (H ₂ SO ₄)	0.188	0.230	0.175	0.131	0.184	0.210	0.168	0.157	0.115	0.198	0.155	0.198	0.155	0.142	0.105	-	-	-	
PM ₁₀ (Filterables and condensables)	1.147	1.777	1.008	1.008	1.279	1.575	1.046	1.008	1.008	1.638	1.008	1.638	1.008	1.008	1.008	-	-	-	
PM ₁₀ (Filterables, condensables and sulfates)	1.400	2.056	1.244	1.184	1.527	1.929	1.272	1.219	1.153	1.905	1.218	1.905	1.218	1.199	1.149	1.217	1.215	1.184	

Notes:
 1) Proposed method of emission control for NO_x is Dry Low-NO_x Burners and SCR when firing natural gas.
 2) Sulfur Trioxide, Sulfuric Acid Mist and Ammonia Sulfate emissions are calculated by the following methodology:
 $SO_3 \rightarrow SO_2$ conversion = 20%
 $SO_3 \text{ lb/hr} = SO_2 \text{ lb/hr} * (80 \text{ MW}_{2007/64 \text{ MW}_{2007}})^{2.02}$
 $H_2SO_4 \text{ lb/hr} = SO_3 \text{ lb/hr} * (98 \text{ MW}_{100} / 80 \text{ MW}_{200})$
 $(NH_4)_2SO_4 \text{ lb/hr} = H_2SO_4 \text{ lb/hr} * 0.32 \text{ MW}_{100} / 98 \text{ MW}_{100}$

Controlled CTG and DB Stack Emissions, lb/MW-hr	Emissions																		
NO _x	0.030	0.056	0.04	0.035	0.039	0.039	0.030	0.035	0.037	0.035	0.035	0.034	0.034	0.035	0.035	0.035	0.035	0.035	0.035
CO	0.030	0.060	0.037	0.129	0.040	0.059	0.030	0.038	0.163	0.035	0.035	0.030	0.030	0.040	0.040	0.035	0.035	0.035	0.035
VOC	0.005	0.017	0.008	0.024	0.010	0.016	0.005	0.008	0.026	0.015	0.005	0.015	0.005	0.005	0.008	0.005	0.005	0.005	0.005
SO ₂	0.015	0.018	0.020	0.019	0.015	0.017	0.014	0.020	0.019	0.015	0.015	0.015	0.015	0.015	0.021	0.020	0.020	0.020	0.020
SO ₃	0.004	0.004	0.005	0.005	0.004	0.004	0.004	0.005	0.005	0.004	0.004	0.004	0.004	0.004	0.005	0.005	0.005	0.005	0.005
NH ₃	0.035	0.035	0.044	0.030	0.034	0.034	0.036	0.047	0.032	0.030	0.036	0.036	0.035	0.035	0.048	0.038	0.038	0.038	0.038
Sulfuric Acid Mist (H ₂ SO ₄)	0.004	0.005	0.006	0.006	0.004	0.005	0.004	0.005	0.005	0.005	0.005	0.005	0.005	0.006	0.006	0.006	0.006	0.006	0.006
Ammonia Sulfates ((NH ₄) ₂ SO ₄)	0.005	0.007	0.008	0.008	0.006	0.007	0.006	0.008	0.008	0.006	0.006	0.006	0.006	0.006	0.009	0.008	0.008	0.008	0.008
PM ₁₀ (Filterables and condensables)	0.027	0.042	0.032	0.046	0.031	0.041	0.027	0.040	0.032	0.040	0.039	0.040	0.039	0.040	0.042	0.039	0.039	0.039	0.039
PM ₁₀ (Filterables, condensables and sulfates)	0.033	0.049	0.043	0.049	0.037	0.048	0.033	0.048	0.030	0.045	0.035	0.045	0.035	0.045	0.049	0.049	0.049	0.049	0.049

**Appendix B: Table B-2
CPV Valley Energy Center
Combined Cycle Turbine Emissions
Distillate Oil Firing**

SWPC5000F Combustion Turbine in Combined Cycle Mode

CT Operating Mode	-5			51			90				Startup Emissions			
	100% Distillate	85% Distillate	70% Distillate	51 BASE Distillate	51 85% Distillate	51 70% Distillate	90 BASE Distillate	90 BASE Distillate	90 85% Distillate	90 70% Distillate	51 Cold Start Distillate	51 Warm Start Distillate	51 Hot Start Distillate	
Ambient Temp (°F)	-5	-5	-5	51	51	51	90	90	90	90	51	51	51	
% Load	100%	85%	70%	BASE	85%	70%	BASE	BASE	85%	70%	Cold Start	Warm Start	Hot Start	
Fuel Type	Distillate	Distillate	Distillate	Distillate	Distillate	Distillate	Distillate	Distillate	Distillate	Distillate	Off	Off	On	
Evaporative Cooler Operation (85% effectiveness)	Off	Off	Off	Off	Off	Off	On	Off	Off	Off	Off	Off	On	
Combustion Turbine (CTG) Heat Input, mmBtu/hr (HHV)	2,145	1,867	1,606	1,894	1,662	1,436	1,757	1,698	1,504	1,303	1,435.9	1,435.9	1,435.9	
Combined Power Output of 2 CTG's & STG (MW)	635.6	456.8	380.0	566.3	400.1	332.7	516.9	501.5	351.3	293.3	-	-	-	
Controlled CTG Pollutant Concentrations														
NO _x	ppmvd @ 15% O ₂	6.0	6.0	6.0	6.0	6.0	6.0	6.0	6.0	6.0	-	-	-	
CO	ppmvd @ 15% O ₂	2.0	2.0	2.0	2.0	2.0	2.0	2.0	2.0	2.0	-	-	-	
VOC	ppmvd @ 15% O ₂	0.7	0.7	0.7	0.7	0.7	0.7	0.7	0.7	0.7	-	-	-	
NH ₃	ppmvd @ 15% O ₂	5.0	5.0	5.0	5.0	5.0	5.0	5.0	5.0	5.0	-	-	-	
Controlled CTG Emission Factors, lb/mmBtu (HHV)														
NO _x		0.0240	0.0239	0.0240	0.0240	0.0240	0.0240	0.0240	0.0240	0.0240	-	-	-	
CO		0.0035	0.0073	0.0146	0.0049	0.0073	0.0146	0.0049	0.0048	0.0073	-	-	-	
VOC		0.0010	0.0010	0.0010	0.0010	0.0010	0.0010	0.0010	0.0010	0.0010	-	-	-	
SO _x		0.0015	0.0015	0.0015	0.0015	0.0015	0.0015	0.0015	0.0015	0.0015	-	-	-	
Sulfuric Acid Mist (H ₂ SO ₄)		0.0005	0.0005	0.0005	0.0005	0.0005	0.0005	0.0005	0.0005	0.0005	-	-	-	
PM-10 (filterables and condensables and sulfates)		0.0239	0.0242	0.0361	0.0244	0.0247	0.0368	0.0240	0.0242	0.0246	-	-	-	
Controlled CTG Stack Emissions, lb/hr														
NO _x		51.43	44.71	38.57	45.43	39.86	34.43	42.14	40.71	36.14	31.29	81.48	91.74	87.19
CO		7.43	13.60	23.40	9.20	12.20	21.00	8.60	8.20	11.00	19.00	323.48	375.76	369.52
VOC		2.10	1.82	1.54	1.82	1.61	1.40	1.68	1.68	1.47	1.26	187.12	198.28	173.61
SO _x		3.27	2.85	2.45	2.89	2.53	2.19	2.68	2.59	2.29	1.99	-	-	-
SO ₃		0.82	0.71	0.61	0.72	0.63	0.55	0.67	0.65	0.57	0.50	-	-	-
NH ₃		12.27	10.80	9.74	11.06	9.89	8.96	9.92	7.91	6.55	10.06	-	-	-
Sulfuric Acid Mist (H ₂ SO ₄)		1.00	0.87	0.75	0.88	0.78	0.67	0.82	0.79	0.70	0.61	-	-	-
Ammonia Sulfates (NH ₃ , SO _x)		1.35	1.17	1.01	1.19	1.04	0.90	1.10	1.07	0.95	0.82	-	-	-
PM-10 (filterables and condensables)		50.00	44.00	57.00	45.00	40.00	52.00	41.00	40.00	36.00	47.00	-	-	-
PM-10 (filterables, condensables and sulfates)		51.35	45.17	58.01	46.19	41.04	52.90	42.10	41.07	36.95	47.82	53.05	52.40	52.16
Stack Parameters														
Stack Diameter, m		5.79	5.79	5.79	5.79	5.79	5.79	5.79	5.79	5.79	5.79	5.79	5.79	5.79
Stack Diameter, ft		19.0	19.0	19.0	19.0	19.0	19.0	19.0	19.0	19.0	19.0	19.0	19.0	19.0
Exhaust Flow per Stack (lb/hr)		4,442	3,906	3,500	4,015	3,587	3,231	3,712	3,621	3,277	2,955	1,615	1,615	1,615
Exhaust Volume, acfm		1,274.010	1,111.200	976.380	1,147.230	1,005.240	894.180	1,069.140	1,069.140	895.050	824.100	447.090	447.090	447.090
Stack Exit Velocity, ft/s		74.9	65.3	57.4	67.4	59.1	52.6	62.8	62.8	52.6	48.4	26.3	26.3	26.3
Stack Exit Velocity, m/s		22.8	19.9	17.5	20.6	18.0	16.0	19.2	19.2	16.0	14.8	8.0	8.0	8.0
Stack Exit Temperature, °F		209	192	192	204	185	185	203	203	185	185	118	118	118
Stack Exit Temperature, deg.K		371.5	362.0	366.0	368.7	358.2	358.2	368.2	368.2	358.2	358.2	320.9	320.9	320.9
Emission Rates, g/s														
NO _x		6.480	5.634	4.860	5.724	5.022	4.338	5.310	5.130	4.554	3.942	10.267	11.559	10.986
CO		0.936	1.714	2.948	1.159	1.537	2.646	1.084	1.033	1.386	2.394	40.759	47.345	46.559
VOC		0.266	0.229	0.194	0.229	0.203	0.176	0.212	0.212	0.185	0.159	23.577	24.983	21.875
SO _x		0.412	0.359	0.308	0.364	0.319	0.276	0.337	0.326	0.289	0.250	-	-	-
Sulfuric Acid Mist (H ₂ SO ₄)		0.126	0.110	0.094	0.111	0.098	0.084	0.103	0.100	0.088	0.077	-	-	-
PM-10 (filterables and condensables)		6.300	5.544	7.182	5.670	5.040	6.552	5.166	5.040	4.536	5.922	-	-	-
PM-10 (filterables, condensables and sulfates)		6.470	5.692	7.309	5.820	5.172	6.666	5.305	5.175	4.655	6.025	6.685	6.603	6.572

- Notes:**
1) Proposed method of emission control for NO_x is water injection and SCR when firing fuel oil.
2) Sulfur Trioxide, Sulfuric Acid Mist and Ammonia Sulfates emissions are calculated by the following methodology:
SO_x ----> SO₃ conversion =
SO₃ lb/hr = SO_x lb/hr * (80 MW_{100%} / 64 MW_{100%}) * 20%
H₂SO₄ lb/hr = SO₃ lb/hr * (98 MW_{H2SO4} / 80 MW_{100%})
(NH₃)₂SO₄ lb/hr = H₂SO₄ lb/hr * (132 MW_{NH3SO4} / 98 MW_{H2SO4})

Heat Rate (Btu/kW-hr) (HHV)	Full Load Cases	6,751	8,175	8,453	6,689	8,306	8,631	6,798	6,772	8,564	8,888			
Heat Rate (Btu/kW-hr) (HHV)	Draft Permit Limit				7,605									
	(@ ISO Conditions without duct firing)													

Appendix B: Table B-3 CPV Valley Energy Center Combustion Turbine Natural Gas Startup and Shutdown Emissions

Estimated Siemens 5GT0500F Startup and Shutdown emissions - Natural Gas

Event	Startup Duration (hr)	Turbine NO _x (lb/event)	Stack NO _x ¹ (lb/event)	Turbine CO (lb/event)	Stack CO (lb/event)	VOC ² (lb/event)	Particulate (lb/event)
Cold Start ³ , J1 & CTG ⁴	2.87	237	65	4,013	650	150	23
and CTG ⁴	1.46	157	58	2,333	392	70	14
Warm Start ⁵	1.05	294	78	3,123	500	112	19
	1.28	192	58	2,111	350	74	12
Hot Start ⁵	1.30	177	62	2,330	470	90	17
	0.87	87	44	1,524	235	59	8
Shut Down	1.00	60	43	1,642	227	29	3

1. NO_x
2. VOC
3. Startup after 2 hour shutdown
4. Startup after 30 hour shutdown
5. Startup after 8 hour shutdown

The above data has been determined based on the following assumptions:

1. Auxiliary Boilers in operation to provide HRSG during start-up.
2. Emissions are estimated based upon data provided by Siemens on 10/20/2004
3. NO_x Catalyst used to produce 2 ppmvd at GT full load with duct firing
4. CO and VOC reductions based upon Catalyst performance provided by WEST dated on 11/05/07
5. Stack damper installed to maintain HRSG hot during shut down.

	Type of Start-up or Shut-down Event			
	Cold Startup	Warm Startup	Hot Startup	Shutdown
Duration of Turbine on Load prior to Start-up (hr)	> 10	0.1 to 10	0 to 0.1	
Maximum Duration of Start-up or Shut-down Event (hr)	1.9	0.1	1.8	1
NO _x (lb/hr)	33.00	99.03	34.02	12.30
VOC (lb/hr)	52.43	57.49	50.44	21.00
CO (lb/hr)	109.59	291.04	266.17	100.20

Appendix B: Table B-4 CPV Valley Energy Center Combustion Turbine Fuel Oil Startup and Shutdown Emissions

Estimated Siemens SGT6-3500E Startup and Shutdown emissions- Fuel Oil

Event	Duration (minutes)	Turbine NOx ¹ (lb/short ton)	Stack NOx ¹ (lb/short ton)	Turbine CO (ppm/short ton)	Stack CO (lb/short ton)	VOC ² (lb/short ton)	Particulate (lb/short ton)
Cold Start ³ - 1st CTG	3.89	730	942	6,800	847	271	600
2nd CTG	1.62	406	136	3,727	657	266	0.5
Warm Start ⁴	3.29	560	187	4,000	791	190	110
	1.45	310	140	3,803	610	277	25
Hot Start ⁵	1.07	780	158	4,200	623	317	10.1
	1.19	851	118	3,186	523	197	58
Shut Down	1.06	165	111	1,200	160	67	42

¹ A180_x

² A180_x

³ Startup after 48 hour shutdown

⁴ Startup after 12 hour shutdown

⁵ Startup after 5-hour shutdown

The above data has been determined based on the following assumptions:

1. Auxiliary Boiler in operation to pre-heat HRSG during start-up.
2. Emissions are estimated based upon data provided by Siemens on 10/29/2000.
3. NOx Catalyst sized to produce 5.0 ppmvd at QF full load without firing.
4. CO and VOC reductions based upon Catalyst performance provided by VOC Trained on 01/25/01.
5. Stack damper installed to maintain HRSG hot during shut down.

	Type of Start-up or Shutdown Event			
	Cold Startup	Warm Startup	Hot Startup	Shutdown
Duration of Turbine 90% load prior to Start-up (hr)	3.6	8.1 to 4.8	7 to 8	—
Maximum Duration of Start-up or Shut-down Event (hr)	5	3.1	2	1
NOx (lb/hr)	76.71	88.25	80.99	110.86
VOC (lb/hr)	186.20	209.24	173.34	86.50
CO (lb/hr)	279.16	349.68	316.78	168.50

**Appendix B: Table B-5
CPV Valley Energy Center
Combustion Turbine Startup and Shutdown Emissions Summary**

Event	Fuel	Duration of Shutdown Prior to Startup (hours)	Duration (hours)	NO _x			CO			VOC			PM ₁₀		
				total (lb)	rate (lb/hr)	rate (gram/sec)	total (lb)	rate (lb/hr)	rate (gram/sec)	total (lb)	rate (lb/hr)	rate (gram/sec)	total (lb)	rate (lb/hr)	rate (gram/sec)
Cold Startup	Natural Gas	>48	2.2	76.5	35.4	4.5	580.7	269.1	33.9	114.6	53.1	6.7	20.9	9.7	1.2
Cold Startup	Distillate Oil	>48	2.3	189.5	81.5	10.3	752.1	323.5	40.8	435.1	187.1	23.6	123.4	53.1	6.7
Warm Startup	Natural Gas	8.1 to 48	1.6	66.2	40.9	5.2	539.3	333.6	42.0	93.1	57.6	7.3	15.6	9.6	1.2
Warm Startup	Distillate Oil	8.1 to 48	1.8	163.6	91.7	11.6	670.1	375.8	47.3	353.6	198.3	25.0	93.5	52.4	6.6
Hot Startup	Natural Gas	0 to 8	1.4	52.6	38.0	4.8	456.1	329.7	41.5	71.7	51.8	6.5	13.0	9.4	1.2
Hot Startup	Distillate Oil	0 to 8	1.6	135.2	87.2	11.0	572.8	309.5	46.6	269.1	173.6	21.9	80.9	52.2	6.6
Shutdown	Natural Gas		1.0	42.5	42.5	5.4	127.2	127.2	16.0	21.6	21.6	2.7	8.0	8.0	1.0
Shutdown	Distillate Oil		1.0	110.8	110.8	14.0	168.5	168.5	21.2	86.9	86.9	10.9	42.4	42.4	5.3

(1) Emissions are for a single unit

**Appendix B: Table B-6
CPV Valley Energy Center
Potential Emissions Summary
Maximum Combined Cycle PTE for any Annual Operating Scenario**

Annual Operating Scenario		Natural Gas Only Operation				Gas/Oil Operation			
Maximum Annual Operation With No Startups		Per Unit	2-Unit Total			Per Unit	2-Unit Total		
Annual Turbine Operation, hr/yr		8,760	17,520			8,760	17,520		
Annual Turbine Operation on Natural Gas, hr/yr		8,760	17,520			8,040	16,080		
Annual Turbine Operation on Fuel Oil, hr/yr		0	0			720	1,440		
DB Capacity Factor of Annual Turbine Operation		30%				30%			
Annual DB Operation on Natural Gas, hr/yr		2,628	5,256			2,628	5,256		
Annual Generation, MWh/yr			5,416,245				5,437,381		
Annual Emissions, tons/yr		Per Unit	2-Unit Total	lb/MWh		Per Unit	2-Unit Total		
NO _x		7.13	142.3	0.053		84.23	1,684.6		
CO		101.88	2,037.6	0.075		1,013.0	20,260.0		
VOC		18.68	373.2	0.014		17.98	359.6		
SO ₂		20.9	418.0	0.015		20.12	402.4		
H ₂ SO ₄		6.28	125.6	0.005		6.16	123.2		
PM ₁₀ /PM _{2.5}		5.4	108.0	0.02		68.6	1,372.0		
Annual Operation With Cold & Warm Startups		Per Unit	2-Unit Total			Per Unit	2-Unit Total		
Number of Start-Up on Natural Gas									
Cold		40	80			35	70		
Warm		235	470			219	438		
Hot		0	0			0	0		
Number of Shut-Down on Natural Gas		275	550			255	510		
Operating Time Attributed to Gas SUSD, hr/yr		74	148.0			687	1,374.0		
Downtime Prior to Natural Gas Startups, hr/yr		3,800	7,600			3,480	6,960.0		
Number of Start-Up on Fuel Oil									
Cold		0	0			4	8		
Warm		0	0			16	32		
Hot		0	0			0	0		
Number of Shut-Down on Fuel Oil		0	0			20	40		
Operating Time Attributed to Oil SUSD, hr/yr		0	0			58	116		
Downtime Prior to Fuel Oil Startups, hr/yr		0	0			320	640.0		
Annual Turbine Operation on Natural Gas, hr/yr		4,219	8,438			3,553	7,107		
Annual Turbine Operation on Fuel Oil, hr/yr		0	0			662	1,324		
DB Capacity Factor of Annual Turbine Operation		30%				30%			
Annual DB Operation on Natural Gas, hr/yr		2,628	5,256			2,628	5,256		
Annual Generation, MWh/yr			2,668,470				2,686,812		
Annual Emissions, tons/yr		Per Unit	2-Unit Total	lb/MWh		Per Unit	2-Unit Total		
NO _x		Operation	Start-Ups	Total		Operation	Start-Ups	Total	
NO _x		35.98	1515	321	104.3	49.00	16.84	65.84	131.7
CO		45.11	92.47	137.6	0.206	44.59	94.27	138.8	277.6
VOC		10.00	161.9	26.2	0.039	9.9	19.57	29.0	58.0
SO ₂		10.62	0	10.6	0.016	10.26	0.00	10.3	20.6
H ₂ SO ₄		3.25	0	3.3	0.005	3.14	0.00	3.1	6.3
PM ₁₀ /PM _{2.5}		28.46	3.35	31.8	0.048	44.31	4.52	48.8	97.7
Annual Operation With Cold & Hot Startups		Per Unit	2-Unit Total			Per Unit	2-Unit Total		
Number of Start-Up on Natural Gas									
Cold		40	80			35	70		
Warm		0	0			0	0		
Hot		235	470			219	438		
Number of Shut-Down on Natural Gas		275	550			255	510		
Operating Time Attributed to Gas SUSD, hr/yr		275	550			535	1,070		
Downtime Prior to Natural Gas Startups, hr/yr		2,390	4,780			2,166	4,332.0		
Number of Start-Up on Fuel Oil									
Cold		0	0			4	8		
Warm		0	0			0	0		
Hot		0	0			16	32		
Number of Shut-Down on Fuel Oil		0	0			20	40		
Operating Time Attributed to Oil SUSD, hr/yr		0	0			58	116		
Downtime Prior to Fuel Oil Startups, hr/yr		0	0			224	448.0		
Annual Turbine Operation on Natural Gas, hr/yr		5,684	11,367			5,014	10,028		
Annual Turbine Operation on Fuel Oil, hr/yr		0	0			666	1,332		
DB Capacity Factor of Annual Turbine Operation		30%				30%			
Annual DB Operation on Natural Gas, hr/yr		2,628	5,256			2,628	5,256		
Annual Generation, MWh/yr			3,594,475				3,170,614		
Annual Emissions, tons/yr		Per Unit	2-Unit Total	lb/MWh		Per Unit	2-Unit Total		
NO _x		Operation	Start-Ups	Total		Operation	Start-Ups	Total	
NO _x		48.00	13.55	61.6	0.069	60.09	15.12	75.2	150.4
CO		63.40	82.70	146.1	0.164	62.85	84.38	147.2	294.5
VOC		12.77	13.69	26.5	0.030	12.20	16.55	28.8	57.5
SO ₂		13.81	0	13.8	0.016	13.44	0	13.4	26.9
H ₂ SO ₄		4.23	0	4.2	0.005	4.12	0	4.1	8.2
PM ₁₀ /PM _{2.5}		32.55	3.04	35.9	0.044	37.79	4.14	55.2	111.9
Annual Operation With All Warm Startups		Per Unit	2-Unit Total			Per Unit	2-Unit Total		
Number of Start-Up on Natural Gas									
Cold		0	0			0	0		
Warm		275	550			255	510		
Hot		0	0			0	0		
Number of Shut-Down on Natural Gas		275	550			255	510		
Operating Time Attributed to Gas SUSD, hr/yr		275	550			667	1,335		
Downtime Prior to Natural Gas Startups, hr/yr		2,200	4,400			2,040	4,080.0		
Number of Start-Up on Fuel Oil									
Cold		0	0			4	8		
Warm		0	0			16	32		
Hot		0	0			0	0		
Number of Shut-Down on Fuel Oil		0	0			20	40		
Operating Time Attributed to Oil SUSD, hr/yr		0	0			58	116		
Downtime Prior to Fuel Oil Startups, hr/yr		0	0			320	640.0		
Annual Turbine Operation on Natural Gas, hr/yr		5,640	11,280			5,013	10,026		
Annual Turbine Operation on Fuel Oil, hr/yr		0	0			662	1,324		
DB Capacity Factor of Annual Turbine Operation		30%				30%			
Annual DB Operation on Natural Gas, hr/yr		2,628	5,256			2,628	5,256		
Annual Generation, MWh/yr			3,649,335				3,559,690		
Annual Emissions, tons/yr		Per Unit	2-Unit Total	lb/MWh		Per Unit	2-Unit Total		
NO _x		Operation	Start-Ups	Total		Operation	Start-Ups	Total	
NO _x		49.18	14.95	64.1	0.070	59.98	16.65	76.6	153.3
CO		65.38	9.64	75.0	0.178	62.79	93.52	156.3	312.6
VOC		13.06	15.75	28.8	0.032	12.19	19.19	31.4	62.8
SO ₂		14.15	0	14.2	0.016	13.43	0	13.4	26.9
H ₂ SO ₄		4.33	0	4.3	0.005	4.11	0	4.1	8.2
PM ₁₀ /PM _{2.5}		34.65	3.25	39.9	0.044	37.67	4.43	55.1	112.2
Annual Operation With All Hot Startups		Per Unit	2-Unit Total			Per Unit	2-Unit Total		
Number of Start-Up on Natural Gas									
Cold		0	0			0	0		
Warm		0	0			0	0		
Hot		275	550			255	510		
Number of Shut-Down on Natural Gas		275	550			255	510		
Operating Time Attributed to Gas SUSD, hr/yr		555	1,111			608	1,216		
Downtime Prior to Natural Gas Startups, hr/yr		550	1,100			90	1,800.0		
Number of Start-Up on Fuel Oil									
Cold		0	0			4	8		
Warm		0	0			0	0		
Hot		0	0			16	32		
Number of Shut-Down on Fuel Oil		0	0			20	40		
Operating Time Attributed to Oil SUSD, hr/yr		0	0			58	116		
Downtime Prior to Fuel Oil Startups, hr/yr		0	0			224	448.0		
Annual Turbine Operation on Natural Gas, hr/yr		7,595	15,190			6,698	13,397		
Annual Turbine Operation on Fuel Oil, hr/yr		0	0			666	1,332		
DB Capacity Factor of Annual Turbine Operation		30%				30%			
Annual DB Operation on Natural Gas, hr/yr		2,628	5,256			2,628	5,256		
Annual Generation, MWh/yr			4,686,149				4,188,668		
Annual Emissions, tons/yr		Per Unit	2-Unit Total	lb/MWh		Per Unit	2-Unit Total		
NO _x		Operation	Start-Ups	Total		Operation	Start-Ups	Total	
NO _x		62.07	13.08	75.1	0.064	72.75	14.52	87.4	174.9
CO		86.81	80.20	167.0	0.143	83.90	82.14	166.0	332.1
VOC		16.30	12.83	29.1	0.025	15.38	12.79	31.2	62.3
SO ₂		17.89	0	17.9	0.015	17.11	0	17.1	34.2
H ₂ SO ₄		5.48	0	5.5	0.005	5.24	0	5.2	10.5

**Appendix B: Table B-7
CPV Valley Energy Center
Potential Emissions for the Auxiliary Boiler**

Heat Input (MMBtu/hr, HHV)	48.1	Cleaver Brooks Data
Operating Schedule (hr/yr)	2,100	Permit Condition 65
Annual fuel use (MMBtu/yr)	96,200	Permit Condition 65

Pollutant	Emission Factor (lb/MMBtu)	Reference (State Facility Permit Condition No.)	Emissions (lb/hr)	Emissions (gram/sec)	Emissions (ton/yr)
NO _x	0.02450	67	2.16	0.273	2.16
CO	0.0721	71	3.47	0.437	3.47
VOC	0.0018	66	0.18	0.024	0.18
SO ₂	0.0022	69	0.11	0.013	0.11
PM ₁₀ /PM _{2.5}	0.0063	68	0.30	0.038	0.30
H ₂ SO ₄	0.0002	70	0.01	1.21E-03	9.62E-03

Appendix B: Table B-8 CPV Valley Energy Center Potential Emissions for the Gas Heater

Heat Input (MMBtu/hr)	1,018	Ovenpak 47 data
Number of Heaters	2	
Operating Schedule (hr/yr)	8,760	
Annual fuel use (MMBtu/yr)	78,190	

Pollutant	Emission Factor (lb/MMBtu)	Reference (State Facility Permit Condition No.)	Emissions (lb/hr)	Emissions (gram/sec)	Emissions (ton/yr)
NO _x	0.058	85	0.52	0.065	3.28
CO	0.084	88	0.75	0.095	3.90
VOC	0.011	86	0.10	0.012	0.13
SO _x	0.0022	90	0.020	0.0025	0.09
PM ₁₀ /PM _{2.5}	0.0070	89	0.068	0.0086	0.30
H ₂ SO ₄	0.0002	87	1.70E-03	2.26E-04	7.35E-03

Appendix B: Table B-9 CPV Valley Energy Center Potential Emissions for the Emergency Generator

Operating Hours:	500	Stack Parameters ¹	
Fuel Type:	ULSD	Stack ID (ft.)	1.50
Heating Value, Btu (MMBtu/gal)	139,000	Exhaust Flow (acfm)	7,860
Gallons per Hour:	725		
Fuel Input (MMBtu/hr)	1008	Stack Temperature (°F)	1,023
BHP Rating:	1495		
Annual Fuel Usage (gal/year)	36,250		
Sulfur Content in Fuel:	0.0015%		

Pollutant	Emission Factor (lbs/MMBtu)	Emission Factor (g/kW-hr)	Source	Short Term Emissions (lb/hr)	Long Term Emissions (ton/yr)
Criteria Air Pollutants					
NO _x		5.42	1	13.32	3.330
CO		0.80	1	1.97	0.492
SO _x	1.58E-03		2	1.54E-02	3.86E-03
VOC		0.230	1	5.65E-01	0.141
PM ₁₀ /PM _{2.5}		0.080	1	1.97E-01	0.049
PM		0.080	1	1.97E-01	0.049
Sulfuric Acid	3.10E-05		3/4	3.13E-03	7.82E-05

1. Kolder spec REOZDE1000, MPU 16V2000 G80 TB
2. Mass balance
3. Emissions based on Toxic Air Pollutant Emission Factors - A Compilation for Selected Air Toxics Compounds and Sources: October, 1999, EPA-450/2-90-011.
4. Emission factor for sulfuric acid is 8.g(%S).mg.1.

Appendix B: Table B-10 CPV Valley Energy Center Potential Emissions for the Fire Water Pump Engine

Operating Hours:	500	Stack Parameters ¹	
Fuel Type:	ULSD	Stack ID (ft.)	0.50
Heating Value, Btu (MMBtu/gal)	139,000	Exhaust Flow (acfm)	1.810
Gallons per Hour:	0.1		
Fuel Input (MMBtu/hr)	1.06	Stack Temperature (°F)	600.0
BHP Rating:	284		
Annual Fuel Usage (gal/year)	7,050		
Sulfur Content in Fuel:	0.0015%		

Pollutant	Emission Factor (lbs/MMBtu)	Emission Factor (g/hp-hr)	Source	Short Term Emissions (lb/hr)	Long Term Emissions (ton/yr)
Criteria Air Pollutants					
NO _x		3.20	1	1.27	0.342
CO		1.42	1	0.88	0.220
SO _x	1.58E-03		2	3.00E-03	7.51E-04
VOC		0.123	1	7.65E-02	0.019
PM ₁₀ /PM _{2.5}		0.118	1	7.34E-02	0.018
PM		0.118	1	7.34E-02	0.018
Sulfuric Acid	3.10E-05		3/4	6.08E-05	1.52E-05

1. Cumulus spec CFP9E-P20
2. Mass balance
3. Emissions based on Toxic Air Pollutant Emission Factors - A Compilation for Selected Air Toxic Compounds and Sources: October, 1999, EPA-450/2-90-011.
4. Emission factor for sulfuric acid is 8.g(%S)/mg J.

Appendix B: Table B-11
CPV Valley Energy Center
Facility-Wide Potential to Emit

Pollutant	Combined Cycle Units (tons/yr)	Auxiliary Boiler (tons/yr)	Emergency Diesel Generator (tons/yr)	Fire Pump (tons/yr)	Dew Point Natural Gas Heaters (tons/yr)	Oil Storage Tank (tons/yr)	Facility (tons/yr)
NO _x	174.9	2.16	3.33	0.34	2.28	N/A	183.0
CO	334.0	3.47	0.49	0.22	3.30	N/A	341.5
VOC	62.8	0.18	0.00	0.00	0.43	0.17	64.0
SO ₂	41.0	0.11	0.14	0.02	0.09	N/A	42.0
PM/PM ₁₀ /PM _{2.5}	94.2	0.30	0.05	0.02	0.30	N/A	95.0
H ₂ SO ₄	12.6	0.01	0.00008	0.00002	0.01	N/A	13.0
NH ₃	104.8	N/A	N/A	N/A	N/A	N/A	104.8

**Appendix B: Table B-14
CPV Valley Energy Center
Facility-Wide Potential CO2 Emissions**

Source(s)	Natural Gas Only							Natural Gas + Oil - With Dual Burning							Maximum Annual CO ₂ (tons)
	Fuel	Hours/yr (2 units)	MMBtu/hr (1 unit)	MW-hr (2 units)	Factor (lb/MMBtu)	Factor (lb/MW-hr)	CO ₂ (tons)	Fuel	Hours (2 units)	MMBtu/hr (1 unit)	MW-hr (2 units)	Factor (lb/MMBtu)	Factor (lb/MW-hr)	CO ₂ (tons)	
2 CTGs	Gas	17,920	1,998	849	110	877	1,925,876	Gas	16,080	1,998	849	110	877	1,767,401	
2 CTGs	Oil	0	0	0	0	0	0	Oil	1,440	2,145	636	157	1,060	2,42,510	
2 DBs	Gas	5,256	500	849	117.5	181	154,926	Gas	5,256	500	849	117.5	181	154,926	
Total CCs	(/year)	17,920	37,640,288	5,687,684	111	751	2,080,202	(/year)	17,920	37,851,865	5,677,831	114	708	2,164,468	

MATS Rule	
MMBtu/yr (2 units)	Portion of Total
16,387,028	79.14%
3,089,304	14.92%
1,230,000	5.94%
20,706,332	

MATS Rule	
MMBtu/yr (2 units)	Portion of Total
17,546,110	85.08%
3,089,304	14.92%
0	0.00%
20,635,414	

Source	Fuel	Hours/yr	MMBtu/hr	Factor (lb/MMBtu)	CO ₂ (tons)
Aux Boiler	Gas	2,000	48.1	117.5	567
2 Gas Heaters	Gas	8,760	9.0	117.5	465

Source	Fuel	Hours/yr	MMBtu/hr	Factor (lb/MMBtu)	CO ₂ (tons)
EG	Oil	500	10.08	164	43
FWP	Oil	500	1.95	164	80

Total PTE 2,175,204



CPV Valley Energy Center
50 Braintree Hill Office Park
Suite 300
Braintree, MA 02184

ATTACHMENT 4

Current Air State Permit to Operate

(no changes to permit conditions as they
are migrated to the Title V)



CPV Valley Energy Center

- Original Permit

- No changes requested with this submission for the Title V Application.

IDENTIFICATION INFORMATION

Permit Type: Air State Facility

Permit ID: 3-3356-00136/00001

Effective Date: 06/01/2013 Expiration Date: 07/31/2018

Permit Issued To: COMPETITIVE POWER VENTURES INC.
50 BRAINTREE HILL OFFICE PARK
SUITE 300
BRAintree, MA 02184

Contact: STEVE REMILLARD
CPV VALLEY LLC
35 BRAINTREE HILL OFFICE PARK, STE 400
BRAintree, MA 02184
(81) 837-8970

Facility: CPV VALLEY ENERGY CENTER
US RTE 6, RTE 17 AND INTERSTATE 84
MIDDLETOWN, NY

Description:

pre-construction permit

By acceptance of this permit, the permittee agrees that the permit is contingent upon strict compliance with the ECL, all applicable regulations, the General Conditions specified and any Special Conditions included as part of this permit.

Permit Administrator: CHRISTOPHER M HOGAN
615 BROADWAY
ALBANY, NY 12233

Authorized Signature: _____

Date: ___ / ___ / ___



Notification of Other State Permit Obligations

Item A: Permittee Accepts Legal Responsibility and Agrees to Indemnification

The permittee expressly agrees to indemnify and hold harmless the Department of Environmental Conservation of the State of New York, its representatives, employees and agents ("DEC") for all claims, suits, actions, and damages, to the extent attributable to the permittee's acts or omissions in connection with the compliance permittee's undertaking of its duties in connection with, or operation and maintenance of the facility or facilities authorized by the permit whether in compliance or not in any compliance with the terms and conditions of the permit. This indemnification does not extend to any claims, suits, actions, or damages to the extent attributable to DEC's own negligent or intentional acts or omissions, or to any claims, suits, or actions naming the DEC and arising under article 78 of the New York Civil Practice Laws and Rules or any citizen suit or civil rights provision under federal or state laws.

Item B: Permittee's Contractors to Comply with Permit

The permittee is responsible for informing its independent contractors, employees, agents and assigns of their responsibility to comply with this permit, including all special conditions while acting as the permittee's agent with respect to the permitted activities, and such persons shall be subject to the same sanctions for violations of the Environmental Conservation Law as those prescribed for the permittee.

Item C: Permittee Responsible for Obtaining Other Required Permits

The permittee is responsible for obtaining any other permits, approvals, lands, easements and rights-of-way that may be required to carry out the activities that are authorized by this permit.

Item D: No Right to Trespass or Interfere with Riparian Rights

This permit does not convey to the permittee any right to trespass upon the lands or interfere with the riparian rights of others in order to perform the permitted work nor does it authorize the impairment of any rights, title, or interest in real or personal property held or vested in a person not a party to the permit.



LIST OF CONDITIONS

DEC GENERAL CONDITIONS

General Provisions

Facility Inspection by the Department

Facility Inspection by the Department

Facility Inspection by the Department

Relationship of this Permit to Other Department Orders and
Determinations

Relationship of this Permit to Other Department Orders and
Determinations

Relationship of this Permit to Other Department Orders and
Determinations

Applications for permit renewals, modifications and transfers

Applications for permit renewals, modifications and transfers

Applications for permit renewals, modifications and transfers

Permit modifications, suspensions or revocations by the Department

Permit modifications, suspensions or revocations by the Department

Permit modifications, suspensions or revocations by the Department

Facility Level

Submission of application for permit modification or
renewal REGION 3 HEADQUARTERS



DEC GENERAL CONDITIONS
General Provisions
GENERAL CONDITIONS - Apply to ALL Authorized Permits.

Condition 1: Facility Inspection by the Department

Applicable State Requirement: ECL 19-0305

Item 1.1:

The permitted site or facility, including relevant records, is subject to inspection at reasonable hours and intervals by an authorized representative of the Department of Environmental Conservation (the Department) to determine whether the permittee is complying with this permit and the ECL. Such representative may order the work suspended pursuant to ECL 71-0201 and NAPA 401(5).

Item 1.2:

The permittee shall provide a person to accompany the Department's representative during an inspection to the permit area when requested by the Department.

Item 1.3:

A copy of this permit, including all referenced maps, drawings and special conditions, must be available for inspection by the Department at all times at the project site or facility. Failure to produce a copy of the permit upon request by a Department representative is a violation of this permit.

Condition 1: Facility Inspection by the Department

Applicable State Requirement: ECL 19-0305

Item 1.1:

The permitted site or facility, including relevant records, is subject to inspection at reasonable hours and intervals by an authorized representative of the Department of Environmental Conservation (the Department) to determine whether the permittee is complying with this permit and the ECL. Such representative may order the work suspended pursuant to ECL 71-0201 and NAPA 401(5).

Item 1.2:

The permittee shall provide a person to accompany the Department's representative during an inspection to the permit area when requested by the Department.

Item 1.3:

A copy of this permit, including all referenced maps, drawings and special conditions, must be available for inspection by the Department at all times at the project site or facility. Failure to produce a copy of the permit upon request by a Department representative is a violation of this permit.

Condition 1: Facility Inspection by the Department

Applicable State Requirement: ECL 19-0305

Item 1.1:

The permitted site or facility, including relevant records, is subject to inspection at reasonable hours and intervals by an authorized representative of the Department of Environmental Conservation (the Department) to determine whether the permittee is complying with this permit and the ECL. Such representative may order the work suspended pursuant to ECL 71-0201 and NAPA 401(5).



S. (P.A. 40163).

Item 1.2:

The permittee shall provide a person to accompany the Department's representative during an inspection to the permit area when requested by the Department.

Item 1.3:

A copy of this permit, including all referenced maps, drawings and special conditions, must be available for inspection by the Department at all times at the project site or facility. Failure to produce a copy of the permit upon request by a Department representative is a violation of the permit.

Condition 2: Relationship of this Permit to Other Department Orders and Determinations
Applicable State Requirement: ECL 3-0301 (2) (m)

Item 2.1:

Unless expressly provided for by the Department, issuance of this permit does not modify, supersede or rescind any order or determination previously issued by the Department or any of the terms, conditions or requirements contained in such order or determination.

Condition 2: Relationship of this Permit to Other Department Orders and Determinations
Applicable State Requirement: ECL 3-0301 (2) (n)

Item 2.1:

Unless expressly provided for by the Department, issuance of this permit does not modify, supersede or rescind any order or determination previously issued by the Department or any of the terms, conditions or requirements contained in such order or determination.

Condition 2: Relationship of this Permit to Other Department Orders and Determinations
Applicable State Requirement: ECL 3-0301 (2) (n)

Item 2.1:

Unless expressly provided for by the Department, issuance of this permit does not modify, supersede or rescind any order or determination previously issued by the Department or any of the terms, conditions or requirements contained in such order or determination.

Condition 3: Applications for permit renewals, modifications and transfers
Applicable State Requirement: 6 NYCRR 621.11

Item 3.1:

The permittee must submit a separate written application to the Department for renewal, modification or transfer of this permit. Such application must include any forms or supplemental information the Department requires. Any renewal, modification or transfer granted by the Department must be in writing.

Item 3.2:

The permittee must submit a renewal application at least 180 days before expiration of permits for Title V Facility Permits, or at least 30 days before expiration of permits for State Facility Permits.

Item 3.3:

Permits are transferrable with the approval of the department unless specifically prohibited by



submitted prior to actual transfer of ownership.

Condition 3: Applications for permit renewals, modifications and transfers
Applicable State Requirement: 6 NYCRR 621.11

Item 3.1:

The permittee must submit a separate written application to the Department for renewal, modification or transfer of this permit. Such application must include any forms or supplemental information the Department requires. Any renewal, modification or transfer granted by the Department must be in writing.

Item 3.2:

The permittee must submit a renewal application at least 180 days before expiration of permits for Title V Facility Permits, or at least 30 days before expiration of permits for State Facility Permits.

Item 3.3:

Permits are transferable with the approval of the department unless specifically prohibited by the statute, regulation or another permit condition. Applications for permit transfer should be submitted prior to actual transfer of ownership.

Condition 3: Applications for permit renewals, modifications and transfers
Applicable State Requirement: 6 NYCRR 621.11

Item 3.1:

The permittee must submit a separate written application to the Department for renewal, modification or transfer of this permit. Such application must include any forms or supplemental information the Department requires. Any renewal, modification or transfer granted by the Department must be in writing.

Item 3.2:

The permittee must submit a renewal application at least 180 days before expiration of permits for Title V Facility Permits, or at least 30 days before expiration of permits for State Facility Permits.

Item 3.3:

Permits are transferable with the approval of the department unless specifically prohibited by the statute, regulation or another permit condition. Applications for permit transfer should be submitted prior to actual transfer of ownership.

Condition 4: Permit modifications, suspensions or revocations by the Department
Applicable State Requirement: 6 NYCRR 621.13

Item 4.1:

The Department reserves the right to exercise all available authority to modify, suspend, or revoke this permit in accordance with 6 NYCRR Part 621. The grounds for modification, suspension or revocation include:

- a) materially false or inaccurate statements in the permit application or supporting papers;
- b) failure by the permittee to comply with any terms or conditions of the permit;
- c) exceeding the scope of the project as described in the permit application;
- d) newly discovered material information or a material change in environmental conditions,



c) noncompliance with previously issued permit conditions, orders of the commissioner, any provisions of the Environmental Conservation Law or regulations of the Department related to the permitted activity.

Condition 4: Permit modifications, suspensions or revocations by the Department
Applicable State Requirement: 6 NYCRR 621.13

Item 4.1:

The Department reserves the right to exercise all available authority to modify, suspend, or revoke this permit in accordance with 6 NYCRR Part 621. The grounds for modification, suspension or revocation include:

- a) materially false or inaccurate statements in the permit application or supporting papers;
- b) failure by the permittee to comply with any terms or conditions of the permit;
- c) exceeding the scope of the project as described in the permit application;
- d) newly discovered material information or a material change in environmental conditions, relevant technology or applicable law or regulations since the issuance of the existing permit;
- e) noncompliance with previously issued permit conditions, orders of the commissioner, any provisions of the Environmental Conservation Law or regulations of the Department related to the permitted activity.

Condition 4: Permit modifications, suspensions or revocations by the Department
Applicable State Requirement: 6 NYCRR 621.13

Item 4.1:

The Department reserves the right to exercise all available authority to modify, suspend, or revoke this permit in accordance with 6 NYCRR Part 621. The grounds for modification, suspension or revocation include:

- a) materially false or inaccurate statements in the permit application or supporting papers;
- b) failure by the permittee to comply with any terms or conditions of the permit;
- c) exceeding the scope of the project as described in the permit application;
- d) newly discovered material information or a material change in environmental conditions, relevant technology or applicable law or regulations since the issuance of the existing permit;
- e) noncompliance with previously issued permit conditions, orders of the commissioner, any provisions of the Environmental Conservation Law or regulations of the Department related to the permitted activity.

www Facility Level www

**Condition 5: Submission of application for permit modification or renewal-REGION 3
HEADQUARTERS**
Applicable State Requirement: 6 NYCRR 621.6 (a)

Item 5.1:

Submission of applications for permit modification or renewal are to be submitted to:
NYSDEC Regional Permit Administrator
Regional Office

New York State Department of Environmental Conservation
Facility DEC ID: 3335600136



Division of Environmental Permits
21 South Platt Corners Road
New Paltz, NY 12561-1696
(845) 256-3054



Permit Under the Environmental Conservation Law (ECL)

ARTICLE 19, AIR POLLUTION CONTROL - AIR STATE FACILITY
PERMIT

IDENTIFICATION INFORMATION

Permit Issued To: COMPETITIVE POWER VENTURES INC
50 BRAINTREE HILL OFFICE PARK
SUITE 300
BRAintree MA 02184

Facility: CPV VALLEY ENERGY CENTER
US RTE 6 - RTE 17 AND INTERSTATE 84
MIDDLETOWN, WV

Authorized Activity By Standard Industrial Classification Code
4911 - ELECTRIC SERVICES

Permit Effective Date: 08/01/2013

Permit Expiration Date: 07/31/2018



LIST OF CONDITIONS

FEDERALLY ENFORCEABLE CONDITIONS

Facility Level

- 1 6 NYCRR 200.7: Maintenance of Equipment
- 2 6 NYCRR 202-1.1: Required Emissions Tests
- 3 6 NYCRR 200.7: Compliance Demonstration
- 4 6 NYCRR 200.7: Compliance Demonstration
- 5 6 NYCRR 201-1.4 (a): Compliance Demonstration
- 6 6 NYCRR 201-6.3 (a) (2): Title V Permit Requirement
- 7 6 NYCRR Subpart 201-7: Facility Permissible Emissions
- *8 6 NYCRR Subpart 201-7: Capping Monitoring Condition
- 9 6 NYCRR 211.1: Air pollution prohibited
- 10 6 NYCRR 231-5.3: Facility PTE
- 11 6 NYCRR 231-5.4: Compliance Demonstration
- 12 6 NYCRR 231-5.4: Compliance Demonstration
- 13 6 NYCRR 231-5.4: Compliance Demonstration
- 14 6 NYCRR 231-5.4: Compliance Demonstration
- 15 6 NYCRR 231-5.5: Emission offset
- 16 6 NYCRR 231-5.5: Emission offsets
- 17 6 NYCRR 231-5.5: offsets
- 18 6 NYCRR 231-7.5: Facility potential to emit
- 19 6 NYCRR 231-7.6: Compliance Demonstration
- 20 6 NYCRR 231-7.6: Compliance Demonstration
- 21 6 NYCRR 231-7.6: Compliance Demonstration
- 22 6 NYCRR 231-7.6: Compliance Demonstration
- 23 6 NYCRR 231-7.6: Compliance Demonstration
- 24 6 NYCRR 231-7.6: Compliance Demonstration
- 25 6 NYCRR 231-7.6: Compliance Demonstration
- 26 6 NYCRR 231-7.6: Compliance Demonstration
- 27 6 NYCRR 231-7.6: Compliance Demonstration
- 28 6 NYCRR 231-7.6: Compliance Demonstration
- 29 6 NYCRR 231-7.6: Compliance Demonstration
- 30 6 NYCRR 231-7.6: Compliance Demonstration
- 31 6 NYCRR 243-1.6 (a): Permit Requirements
- 32 6 NYCRR 243-1.6 (b): Monitoring requirements
- 33 6 NYCRR 243-1.6 (c): NOx Ozone Season Emission Requirements
- 34 6 NYCRR 243-1.6 (d): Excess emission requirements
- 35 6 NYCRR 243-1.6 (e): Recordkeeping and reporting requirements
- 36 6 NYCRR 243-2.1: Authorization and responsibilities of CAIR designated representative
- 37 6 NYCRR 243-2.4: Certificate of representation
- 38 6 NYCRR 243-8.1: General requirements
- 39 6 NYCRR 243-8.1: Prohibitions
- 40 6 NYCRR 243-8.5 (d): Quarterly reports
- 41 6 NYCRR 243-8.5 (e): Compliance certification
- 42 6 NYCRR Subpart 244-1: CAIR NOx Annual Trading Program General Conditions
- 43 6 NYCRR Subpart 244-2: Designated CAIR Representative
- 44 6 NYCRR Subpart 244-8: Compliance Demonstration



- 45 6 NYCRR Subpart 245-1: CAIR SO₂ Trading Program General Provisions
- 46 6 NYCRR Subpart 245-2: Designated CAIR Representative
- 47 6 NYCRR Subpart 245-8: Compliance Demonstration
- 48 40CFR 60.4, NSPS Subpart A: EPA Region 2 address
- 49 40CFR 60.7(a), NSPS Subpart A: Date of construction notification -
If a COM is not used.
- 50 40CFR 60.7(b), NSPS Subpart A: Recordkeeping requirements
- 51 40CFR 60.7(f), NSPS Subpart A: Facility files for subject sources
- 52 40CFR 60.8(a), NSPS Subpart A: Performance testing timeline
- 53 40CFR 60.8(b), NSPS Subpart A: Performance test methods
- 54 40CFR 60.8(d), NSPS Subpart A: Prior notice
- 55 40CFR 60.8(e), NSPS Subpart A: Performance testing facilities
- 56 40CFR 60.8(f), NSPS Subpart A: Number of required tests
- 57 40CFR 60 NSPS Subpart III: Applicability
- 58 40CFR 60.435 NSPS Subpart KKKK: Compliance Demonstration
- 59 40CFR 60.435(a) NSPS Subpart KKKK: Compliance Demonstration
- 60 40 CFR Part 72: Facility Subject to Title IV Acid Rain Regulations
and Permitting

Emission Unit Level

- 61 6 NYCRR 227-1.3(a): Compliance Demonstration
- 62 6 NYCRR 227-1.3(a): Compliance Demonstration

EU=U-00003

- 63 40CFR 60.43e(c), NSPS Subpart Dc: Compliance Demonstration
- 64 40CFR 60.43e(a), NSPS Subpart Dc: Compliance Demonstration

EU=U-00003,Proc=P3B

- 65 6 NYCRR 231-5.4: Compliance Demonstration
- 66 6 NYCRR 231-5.4: Compliance Demonstration
- 67 6 NYCRR 231-5.4: Compliance Demonstration
- 68 6 NYCRR 231-7.6: Compliance Demonstration
- 69 6 NYCRR 231-7.6: Compliance Demonstration
- 70 6 NYCRR 231-7.6: Compliance Demonstration
- 71 6 NYCRR 231-7.6: Compliance Demonstration

EU=U-00003,Proc=P3B,ES=AUN01

- 72 40CFR 60.43e(g)(2) NSPS Subpart Dc: Alternative recordkeeping

EU=U-00004,Proc=P04

- 73 6 NYCRR 231-5.4: Compliance Demonstration
- 74 6 NYCRR 231-5.4: Compliance Demonstration
- 75 6 NYCRR 231-7.6: Compliance Demonstration
- 76 6 NYCRR 231-7.6: Compliance Demonstration
- 77 6 NYCRR 231-7.6: Compliance Demonstration
- 78 6 NYCRR 231-7.6: Compliance Demonstration

EU=U-00005,Proc=P05

- 79 6 NYCRR 231-5.4: Compliance Demonstration
- 80 6 NYCRR 231-5.4: Compliance Demonstration
- 81 6 NYCRR 231-7.6: Compliance Demonstration
- 82 6 NYCRR 231-7.6: Compliance Demonstration
- 83 6 NYCRR 231-7.6: Compliance Demonstration



64 6 NYCRR 231-7.6: Compliance Demonstration

EU=U-00006,Proc=D06

65 6 NYCRR 231-5.4: Compliance Demonstration

66 6 NYCRR 231-5.4: Compliance Demonstration

67 6 NYCRR 231-7.6: Compliance Demonstration

68 6 NYCRR 231-7.6: Compliance Demonstration

69 6 NYCRR 231-7.6: Compliance Demonstration

90 6 NYCRR 231-7.6: Compliance Demonstration

STATE ONLY ENFORCEABLE CONDITIONS

Facility Level

91 ECL 19-0501: Contaminant List

92 6 NYCRR 201-1.4: Unavoidable noncompliance and violations

93 6 NYCRR Subpart 201-5: Emission Unit Definition

94 6 NYCRR 211.2: Visible Emissions Limited

95 6 NYCRR 242-1.5: CO₂ Budget Trading Program - Excess emission requirements

96 6 NYCRR 242-1.5: Compliance Demonstration

97 6 NYCRR 242-1.5: Compliance Demonstration

Emission Unit Level

98 6 NYCRR Subpart 201-5: Emission Point Definition By Emission Unit

99 6 NYCRR Subpart 201-5: Process Definition By Emission Unit

100 6 NYCRR 251.3(a): Compliance Demonstration

NOTE * preceding the condition number indicates capping.



FEDERALLY ENFORCEABLE CONDITIONS
* * * Facility Level * * *

NOTIFICATION OF GENERAL PERMITTEE OBLIGATIONS

This section contains terms and conditions which are federally enforceable. Permittees may also have other obligations under regulations of general applicability.

Item A: Sealing - 6 NYCRR 200.5

The Commissioner may seal an air contamination source to prevent its operation if compliance with 6 NYCRR Chapter III is not met within the time provided by an order of the Commissioner issued in the case of the violation. Sealing means labeling or tagging a source to notify any person that operation of the source is prohibited, and also includes physical means of preventing the operation of an air contamination source without resulting in destruction of any equipment associated with such source, and includes, but is not limited to, bolting, chaining or wiring shut control panels, apertures or conduits associated with such source.

No person shall operate any air contamination source sealed by the Commissioner in accordance with this section unless a modification has been made which enables such source to comply with all requirements applicable to such modification.

Unless authorized by the Commissioner, no person shall remove or alter any seal affixed to any contamination source in accordance with this section.

Item B: Acceptable Ambient Air Quality - 6 NYCRR 200.6

Notwithstanding the provisions of 6 NYCRR Chapter III, Subchapter A, no person shall allow or permit any air contamination source to emit air contaminants in quantities which alone or in combination with emissions from other air contamination sources would cause air pollution in excess of any applicable ambient air quality standard and/or cause air pollution. In such cases where nonattainment occurs or may occur, the Commissioner shall specify the degree and/or method of emission control required.

Item C: Maintenance of Equipment - 6 NYCRR 200.7

Any person who owns or operates an air contamination source which is equipped with an emission control device shall operate such device and keep it in a satisfactory state of maintenance and repair in accordance with ordinary and necessary practices, standards and procedures, inclusive of manufacturer's specifications,



required to operate such device effectively.

Item D: Unpermitted Emission Sources - 6 NYCRR 201-1.2

If an existing emission source was subject to the permitting requirements of 6 NYCRR Part 201 at the time of construction or modification, and the owner and/or operator failed to apply for a permit for such emission source then the following provisions apply:

(a) The owner and/or operator must apply for a permit for such emission source or register the facility in accordance with the provisions of Part 201.

(b) The emission source or facility is subject to all regulations that were applicable to it at the time of construction or modification and any subsequent requirements applicable to existing sources or facilities.

Item E: Emergency Defense - 6 NYCRR 201-1.5

An emergency constitutes an affirmative defense to an action brought for noncompliance with emissions limitations or permit conditions for all facilities in New York State.

(a) The affirmative defense of emergency shall be demonstrated through properly signed, contemporaneous operating logs, or other relevant evidence that:

(1) An emergency occurred and that the facility owner and/or operator can identify the cause(s) of the emergency;

(2) The equipment at the permitted facility causing the emergency was at the time being properly operated;

(3) During the period of the emergency the facility owner and/or operator took all reasonable steps to minimize levels of emissions that exceeded the emission standards or other requirements in the permit; and

(4) The facility owner and/or operator notified the Department within two working days after the event occurred. The notice must contain a description of the emergency, any steps taken to mitigate emissions, and corrective actions taken.

(b) In any enforcement proceeding, the facility owner and/or operator seeking to establish the occurrence of an emergency has the burden of proof.



(c) This provision is in addition to any emergency or upset provision contained in any applicable requirement.

Item F: Recycling and Salvage - 6 NYCRR 201-1.7

Where practical, any person who owns or operates an air contamination source shall recycle or salvage air contaminants collected in an air cleaning device according to the requirements of 6 NYCRR.

Item G: Prohibition of Retroduction of Collected Contaminants to the Air - 6 NYCRR 201-1.8

No person shall unnecessarily remove, handle, or cause to be handled, collected air contaminants from an air cleaning device for recycling, salvage or disposal in a manner that would reintroduce them to the outdoor atmosphere.

Item H: Proof of Eligibility for Sources Defined as Exempt Activities - 6 NYCRR 201-3.2 (a)

The owner and/or operator of an emission source or unit that is eligible to be exempt, may be required to certify that it operates within the specific criteria described in 6 NYCRR Subpart 201-3. The owner or operator of any such emission source must maintain all required records on-site for a period of five years and make them available to representatives of the Department upon request. Department representatives must be granted access to any facility which contains emission sources or units subject to 6 NYCRR Subpart 201-3, during normal operating hours, for the purpose of determining compliance with this and any other state and federal air pollution control requirements, regulations, or law.

Item I: Proof of Eligibility for Sources Defined as Trivial Activities - 6 NYCRR 201-3.3 (a)

The owner and/or operator of an emission source or unit that is listed as being trivial in 6 NYCRR Part 201 may be required to certify that it operates within the specific criteria described in 6 NYCRR Subpart 201-3. The owner or operator of any such emission source must maintain all required records on-site for a period of five years and make them available to representatives of the Department upon request. Department representatives must be granted access to any facility which contains emission sources or units subject to 6 NYCRR Subpart 201-3, during normal operating hours, for the purpose of determining compliance with this and any other state and federal air pollution control requirements, regulations, or law.

Item J: Required Emission Tests - 6 NYCRR 202-1.1



All acceptable report of measured emissions shall be submitted, as may be required by the Commissioner, to ascertain compliance or noncompliance with any air pollution code, rule, or regulation. Failure to submit a report acceptable to the Commissioner within the time stated shall be sufficient reason for the Commissioner to suspend or deny an operating permit. Notification and acceptable procedures are specified in 6 NYCRR Subpart 202.1.

Item K: **Open Fires Prohibitions - 6 NYCRR 215.2**
Except as allowed by section 215.3 of 6 NYCRR Part 215, no person shall burn, cause, suffer, allow or permit the burning of any materials in an open fire.

Item L: **Permit Exclusion - ECL 19-0305**
The issuance of this permit by the Department and the receipt thereof by the Applicant does not and shall not be construed as barring, dismissing, adjudicating or in any way affecting any legal, administrative or equitable rights or claims, actions, suits, causes of action or demands whatsoever that the Department may have against the Applicant for violations based on facts and circumstances alleged to have occurred or existed prior to the effective date of this permit, including but not limited to, any enforcement action authorized pursuant to the provisions of applicable federal law, the Environmental Conservation Law of the State of New York (ECL) and Chapter III of the Official Compilation of the Codes, Rules and Regulations of the State of New York (NYCRR). The issuance of this permit also shall not in any way affect pending or future enforcement actions under the Clean Air Act brought by the United States or any person.

Item M: **Federally Enforceable Requirements - 40 CFR 70.6 (b)**
All terms and conditions in this permit required by the Act or any applicable requirement, including any provisions designed to limit a facility's potential to emit, are enforceable by the Administrator and citizens under the Act. The Department has, in this permit, specifically designated any terms and conditions that are not required under the Act or under any of its applicable requirements as being enforceable under only state requirements.

FEDERAL APPLICABLE REQUIREMENTS
The following conditions are federally enforceable.

Condition 1: Maintenance of Equipment



Effective between the dates of 08/01/2013 and 07/31/2018

Applicable Federal Requirement: 6 NYCRR 200.7

Item 1.1:

Any person who owns or operates an air contamination source which is equipped with an emission control device shall operate such device and keep it in a satisfactory state of maintenance and repair in accordance with ordinary and necessary practices, standards and procedures, inclusive of manufacturer's specifications, required to operate such device effectively.

Condition 2/ Required Emissions Tests

Effective between the dates of 08/01/2013 and 07/31/2018

Applicable Federal Requirement: 6 NYCRR 203-1.1

Item 2.1:

For the purpose of ascertaining compliance or non-compliance with any air pollution control code, rule or regulation, the commissioner may require the person who owns such air contamination source to submit an acceptable report of measured emissions within a stated time.

Condition 3/ Compliance Demonstration

Effective between the dates of 08/01/2013 and 07/31/2018

Applicable Federal Requirement: 6 NYCRR 200.7

Item 3.1:

The Compliance Demonstration activity will be performed for the facility:

Regulated Contaminant(s):

CAS No: 007664-01-7 AMMONIA

Item 3.2:

Compliance Demonstration shall include the following monitoring:

Monitoring Type: WORK PRACTICE INVOLVING SPECIFIC OPERATIONS

Monitoring Description:

The facility will maintain records to verify concentration of ammonia stored on site is less than 19%.

Work Practice Type: PARAMETER OF PROCESS MATERIAL

Process Material: AMMONIA

Parameter Monitored: CONCENTRATION

Upper Permit Limit: 19 percent

Reference Test Method: EPA Approved

Monitoring Frequency: PER DELIVERY

Averaging Method: MAXIMUM - NOT TO BE EXCEEDED AT ANY TIME (INSTANTANEOUS/DISCRETE OR GRAB)

Reporting Requirements: ANNUALLY (CALENDAR)

Reports due 30 days after the reporting period.



The initial report is due 1/30/2014.
Subsequent reports are due every 12 calendar month(s).

Condition 4: Compliance Demonstration
Effective between the dates of 08/01/2013 and 07/31/2018

Applicable Federal Requirements: 6 NYCRR 200.7

Item 4.1:

The Compliance Demonstration activity will be performed for the facility.
The Compliance Demonstration applies to:

Emission Unit: 11-00001	Emission Point: RP001
Emission Unit: 11-00002	Emission Point: RP002
Regulated Component(s): CAS No: 007664-41-7	AMMONIA

Item 4.2:

Compliance Demonstration shall include the following monitoring:

Monitoring Type: CONTINUOUS EMISSIONS MONITORING (CEM)

Monitoring Description:

The facility shall install, calibrate, maintain and operate continuous emissions monitors for ammonia. The 5.0 ppmvd corrected to 15% Oxygen limit applies during all turbine loads, all fuels being fired and all duct burner operations.

Manufacturer Name/Model Number: Autonomous Analyzer

Parameter Monitored: AMMONIA

Upper Permit Limit: 5.0 parts per million by volume
(dry, corrected to 15% O₂)

Reference Test Method: 40 CFR 60 Appendices B & F

Monitoring Frequency: CONTINUOUS

Averaging Method: 1-HOUR AVERAGE

Reporting Requirement(s): QUARTERLY (CALENDAR)

Reports due 30 days after the reporting period.

The initial report is due 10/30/2013.

Subsequent reports are due every 3 calendar month(s).

Condition 5: Compliance Demonstration
Effective between the dates of 08/01/2013 and 07/31/2018

Applicable Federal Requirements: 6 NYCRR 201-1.3 (a)

Item 5.1:

The Compliance Demonstration activity will be performed for the Facility.

Item 5.2:

Compliance Demonstration shall include the following monitoring:



Monitoring Type: RECORD KEEPING/MAINTENANCE PROCEDURES
Monitoring Description:

The owner or operator shall, within one year following the commencement of operation, submit a Title V permit application to the Department (as per the requirements of paragraph 201-6.3(a)(2)). This application must include start-up, shutdown, and fuel switching data to establish enforceable combustion engine start-up, shutdown, and fuel switching emission rates for NOx, CO, and NH3, and confirm that such established rates would not result in a violation of applicable NAAQS.

In the event that a minimum of 15 start-ups and 15 shutdowns, while firing distillate oil, does not occur within the one year period defined above, the owner or operator will be required to submit start-up and shutdown data, with an application for permit modification, once the 15 start-ups and shutdowns while firing distillate oil occur.

Also, if a minimum of 15 fuel switches does not occur within the one year period defined above, the owner or operator will be required to submit fuel switching data with an application for permit modification once the 15 fuel switches occur.

Monitoring Frequency: CONTINUOUS

Reporting Requirements: ONCE / BATCH OR MONITORING OCCURRENCE

Condition 6: Title V Permit Requirement
Effective between the dates of 08/01/2013 and 07/31/2018

Applicable Federal Requirement: 6 NYCRR 201-6.3 (a) (2)

Item 6.1:

A Title V permit application must be submitted to the Department within one year of commencement of operation of this facility.

Condition 7: Facility Permissible Emissions
Effective between the dates of 08/01/2013 and 07/31/2018

Applicable Federal Requirement: 6 NYCRR Subpart 201-7

Item 7.1:

The sum of emissions from the emission units specified in this permit shall not equal or exceed the following

Potential To Emit (PTE) rate for each regulated contaminant:

CAS No: 0NY075-02-5
Name: PM 2.5

PTE: 190,000 pounds per year



Condition 8: Capping Monitoring Condition
Effective between the dates of 08/01/2013 and 07/31/2018

Applicable Federal Requirement: 6 NYCRR Subpart 201-7

Item 8.1:

Under the authority of 6 NYCRR Part 201-7, this condition contains an emission cap for the purpose of limiting emissions from the facility, emission unit or process to avoid being subject to the following applicable requirement(s) that the facility, emission unit or process would otherwise be subject to:

6 NYCRR 231-2.1

Item 8.2:

Operation of this facility shall take place in accordance with the approved criteria, emission limits, terms, conditions and standards in this permit.

Item 8.3:

The owner or operator of the permitted facility must maintain all required records on-site for a period of five years and make them available to representatives of the Department upon request. Department representatives must be granted access to any facility regulated by this Subpart, during normal operating hours, for the purpose of determining compliance with this and any other state and federal air pollution control requirements, regulations or law.

Item 8.4:

On an annual basis, unless otherwise specified below, beginning one year after the granting of an emissions cap, the responsible official shall provide a certification to the Department that the facility has operated all emission units within the limits imposed by the emission cap. This certification shall include a brief summary of the emissions subject to the cap for that time period and a comparison to the threshold levels that would require compliance with an applicable requirement.

Item 8.5:

The emission of pollutants that exceed the applicability thresholds for an applicable requirement for which the facility has obtained an emissions cap, constitutes a violation of Part 201 and of the Act.

Item 8.6:

The Compliance Demonstration activity will be performed for the Facility:

Regulated Component(s):

CAS No: 000025-02-5 PM-2.5

Item 8.7:

Compliance Demonstration shall include the following monitoring:

Capping: Yes

Monitoring Type: WORK PRACTICE INVOLVING SPECIFIC OPERATIONS

Monitoring Description:

Monthly facility-wide emissions of PM-2.5 will be



calculated as the sum of monthly PM-2.5 emissions from individual emission units or source groups. Emissions will be calculated based on heat input (or, equivalently, from fuel use) and emission factors as described below. Annual facility-wide emissions will then be determined at the end of each month on a rolling 12-month basis in order to demonstrate compliance with the 95 ton per year cap.

The source groups included in the emissions cap along with their associated source indices and PM-2.5 emission factors, as used in subsequent equations, are listed in the following. For each source group, the parameter that will be monitored and the monitoring frequency. Continuous monitoring of heat input to the combustion turbines, auxiliary boiler and gas heater(s) will be provided by a digital data acquisition system (DAS).

Unit	Op Load	Fuel	Cat	Emission Factor
CT only	= 50%	Gas	1	0.0056
CT only	= 50%	Gas	2	0.0073
CT + DB	= 80%	Gas	3	0.0064
CT only	= 85%	Oil	4	0.0247
CT only	= 85%	Oil	5	0.0366
Aux Boiler: All		Gas	6	0.0003
Gas Heater: All		Gas	7	0.0076
EDG	All	Oil	8	0.0091
EFP	All	Oil	9	0.0490

Where CT = combustion turbines, DB = dual burners, Aux Boiler = auxiliary boiler, EDG = emergency diesel generator and EFP = emergency fire pump

For the combustion turbines, the proposed emission factors represent the maximum PM-2.5 emission factor over the specified normal operating loads for the associated fuel and category. In lieu of using the maximum PM-2.5 emission factors, the owner or operator may elect to use representative PM-2.5 stack test data to determine compliance with the annual PM-2.5 emissions cap.

For each source group (j), the PM-2.5 emissions in (ton) (Q_{ij}) for month j will be calculated as follows:
 Q_{ij} = EFi x Hij / 2000, where:

- EFi = PM-2.5 emission factor or representative PM-2.5 stack test data (lb/mmBtu) for source group i
- Hij = monthly heat input (mmBtu) for source group i in



month j

In cases where fuel use (gallons of oil or standard cubic feet of gas) for a source group is monitored directly (rather than heat input, the equivalent heat input will be determined by multiplying the monthly fuel usage for the source group by the corresponding fuel heating value (mmBtu/gallon or mmBtu/scf), using the higher heating value (HHV) basis for the fuel.

The total facility PM-2.5 emissions in month j (Q_j) will be calculated by summing over all source groups ($i = 1$ to 9) as follows: $Q_j = \sum EF_i \times H_i / 2000 = \sum C_{ij}$.

The facility-wide PM-2.5 emissions over the past 12 months (Q_{12m}) ending in month j will be determined by summing the facility-wide PM-2.5 emissions for the most recent 12 months ($k = 0$ to 11) as follows:

$$Q_{12m} = \sum Q_{j-k}$$

After each month, compliance will be demonstrated with the proposed 95 ton/year PM-2.5 emission limit by showing that $Q_{12m} \leq 95$.

The facility shall conduct periodic testing to demonstrate that emissions from the combustion furnaces comply with the lb/mmBtu emission factors for PM-2.5. The combustion furnaces will be tested once per year for the first two years of operation with the first test to be conducted within 180 days of startup.

Work Practice Type: PARAMETER OF PROCESS MATERIAL

Process Material: FUEL

Parameter Monitored: HEAT INPUT

Upper Permit Limit: 95 tons per year

Monitoring Frequency: CONTINUOUS

Averaging Method: 12-month total, rolled monthly

Reporting Requirements: ANNUALLY (CALENDAR)

Reports due 30 days after the reporting period.

The initial report is due 1/30/2014.

Subsequent reports are due every 12 calendar month(s).

Condition 9: Air pollution prohibited
Effective between the dates of 08/01/2013 and 07/31/2018

Applicable Federal Requirement: 6 NYCRR 211.1

Item 9.1:



No person shall cause or allow emissions of air contaminants to the outdoor atmosphere of such quantity, characteristic or duration which are injurious to human, plant or animal life or to property or which unreasonably interfere with the comfortable enjoyment of life or property. Notwithstanding the existence of specific air quality standards or emission limits, this prohibition applies, but is not limited to, any particulate, fume, gas, mist, odor, smoke, vapor, pollen, toxic or deleterious emission, either alone or in combination with others.

Condition 10: Facility PTE
Effective between the dates of 08/01/2013 and 07/31/2018

Applicable Federal Requirement(s) NYCRR 231-5.3

Item 10.1:
CPS Valley Energy Center
Facility Wide Potential to Emit

VOC: 65 tons/yr
NOx: 186.8 tons/yr

Condition 11: Compliance Demonstration
Effective between the dates of 08/01/2013 and 07/31/2018

Applicable Federal Requirement(s) NYCRR 231-5.4

Item 11.1:
The Compliance Demonstration activity will be performed for the facility.
The Compliance Demonstration applies to:

Emission Unit: U-00001 Process: P1A	Emission Point: EP001
Emission Unit: U-00001 Process: P2A	Emission Point: EP001
Emission Unit: U-00002 Process: P01	Emission Point: EP002
Emission Unit: U-00003 Process: P02	Emission Point: EP003
Regulated Contaminant(s) CAS No: 001210-00-0	OXIDES OF NITROGEN

Item 11.2:
Compliance Demonstration shall include the following monitoring:

Monitoring Type: CONTINUOUS EMISSION MONITORING (CEM)
Monitoring Description:
LAER is 2.0 ppmvd corrected to 15% Oxygen. Will be achieved through use of Dry Low NOx combustion technology



and SCR.

The facility shall install, calibrate, maintain and operate a continuous emission monitor.

The limit applies at all loads except during start-up and shutdown.

Manufacturer Name/Model Number: CEM
Upper Permit Limit: 2.0 parts per million by volume
(dry, corrected to 15% O₂)
Reference Test Method: 40 CFR, Part 60, Appendix and Method 7E
Monitoring Frequency: CONTINUOUS
Averaging Method: 1-HOUR AVERAGE
Reporting Requirements: QUARTERLY (CALENDAR)
Reports due 10 days after the reporting period.
The initial report is due 10/30/2013.
Subsequent reports are due every 3 calendar month(s).

Condition 12: Compliance Demonstration
Effective between the dates of 08/01/2013 and 07/31/2018.

Applicable Federal Requirements: NYCRR 231-5.4

Item 12.1:
The Compliance Demonstration activity will be performed for the facility.
The Compliance Demonstration applies to:

Emission Unit: U-00001 Emission Point: EP001
Process: P2A

Emission Unit: U-00002 Emission Point: EP002
Process: P02

Regulated Contaminant(s):
CAS No: 0647998-00-0 VOC

Item 12.2:
Compliance Demonstration shall include the following monitoring:

Monitoring Type: INTERMITTENT EMISSION TESTING

Monitoring Description:

LAER is 1.8 ppmvd corrected to 15% O₂. Will be achieved using good combustion controls and an oxidation catalyst.
Emission testing to be performed within 180 days of startup.

Manufacturer Name/Model Number: CEM
Parameter Monitored: CONCENTRATION
Upper Permit Limit: 1.8 parts per million by volume
(dry, corrected to 15% O₂)
Reference Test Method: Method 25A



Monitoring Frequency: SINGLE OCCURRENCE
Averaging Method: 1-HOUR AVERAGE
Reporting Requirements: ONCE / BATCH OR MONITORING OCCURRENCE

Condition 13: Compliance Demonstration
Effective between the dates of 08/01/2013 and 07/31/2018

Applicable Federal Requirement:6 NYCRR 231-5.4

Item 13.1:
The Compliance Demonstration activity will be performed for the facility.
The Compliance Demonstration applies to:

Emission Unit: U-00001 Process: P3A	Emission Point: EP001
Emission Unit: U-00002 Process: P03	Emission Point: EP002
Regulated Contaminant(s): CAS No.: 08421-00-0	OXIDES OF NITROGEN

Item 13.2:
Compliance Demonstration shall include the following monitoring:

Monitoring Type: CONTINUOUS EMISSION MONITORING (CEM)
Monitoring Description:

LAER is 6.0 ppmvd corrected to 15% Oxygen. Will be achieved using water injection and SCR.

The facility shall install, calibrate, maintain and operate a continuous emission monitor.

The limit applies at all loads except during start up and shutdown.

Manufacturer Name/Model Number: CEM
Upper Permit Limit: 6.0 parts per million by volume
(dry, corrected to 15% O₂)
Reference Test Method: 40 CFR Part 60 Appendix and Method 7E
Monitoring Frequency: CONTINUOUS
Averaging Method: 1-HOUR AVERAGE
Reporting Requirements: QUARTERLY (CALENDAR)
Reports due 30 days after the reporting period.
(The initial report is due 10/30/2013.
Subsequent reports are due every 3 calendar months.)

Condition 14: Compliance Demonstration
Effective between the dates of 08/01/2013 and 07/31/2018

Applicable Federal Requirement:6 NYCRR 231-5.4



Item 14.1:

The Compliance Demonstration activity will be performed for the facility:
The Compliance Demonstration applies to:

Emission Unit: U-00001 Emission Point: EP001
Process: P1A

Emission Unit: U-00001 Emission Point: EP001
Process: P3A

Emission Unit: U-00002 Emission Point: EP002
Process: P01

Emission Unit: U-00002 Emission Point: EP002
Process: P05

Regulated Contaminant(s)
CAS No.: 06Y998-00-0 (VOC)

Item 14.2:

Compliance Demonstration shall include the following monitoring:

Monitoring Type: INTERMITTENT EMISSION TESTING

Monitoring Description:

LAER is 0.7 ppmvd corrected to 15% O₂. Will be achieved using good combustion controls and an oxidation catalyst. Emission testing to be performed within 180 days of startup.

Manufacturer Name/Model Number: CEM

Parameter Monitored: CONCENTRATION

Upper Permit Limit: 0.7 parts per million by volume (dry, corrected to 15% O₂)

Reference Test Method: Method 25A

Monitoring Frequency: SINGLE OCCURRENCE

Averaging Method: 1-HOUR AVERAGE

Reporting Requirements: ONCE / BATCH OR MONITORING OCCURRENCE

Condition 15: Emission offset

Effective between the dates of 08/01/2013 and 07/31/2018

Applicable Federal Requirement: 6 NYCRR 231-5.5

Item 15.1: The potential to emit Oxides of Nitrogen (NO_x) from the facility has been limited to 187 tons per year. NO_x emissions must be offset at a ratio of 1:15 to 1. A total of 210 tons of offsets will be required. The facility will identify the sources of offsets at a later time but prior to construction. There will be a separate noticing at that time.

Condition 16: Emission offsets

Effective between the dates of 08/01/2013 and 07/31/2018



Applicable Federal Requirement:6 NYCRR 231-5.5

Item 16.1: The potential to emit Volatile Organic Compounds (VOC) from the facility has been limited to 65 tons per year. VOC emissions must be offset at a ratio of 1.15 to 1. A total of 75 tons of offsets will be required. The facility will identify the sources of offsets at a later time but prior to construction. There will be a separate activity at that time.

Condition 17: offsets.
Effective between the dates of 08/01/2013 and 07/31/2018

Applicable Federal Requirement:6 NYCRR 231-5.5

INVALID FORMAT OF CONDITION IN LIBRARY

Condition 18: Facility potential to emit
Effective between the dates of 08/01/2013 and 07/31/2018

Applicable Federal Requirement:6 NYCRR 231-7.5

Item 18.1:
CPV Valley Energy Center
Facility Wide Potential to Emit

CO 344 tons/yr
NO₂ 42 Tons/yr
PM-2.5 95 tons/yr
H₂SO₄ 13 tons/yr
CO₂ 2,164,456 tons/yr

Condition 19: Compliance Demonstration
Effective between the dates of 08/01/2013 and 07/31/2018

Applicable Federal Requirement:6 NYCRR 231-7.6

Item 19.1:
The Compliance Demonstration activity will be performed for the facility.
The Compliance Demonstration applies to:

Emission Unit U-00001

Emission Unit U-00001

Item 19.2:
Compliance Demonstration shall include the following monitoring:

Monitoring Type: INTERMITTENT EMISSION TESTING
Monitoring Description:
The combined cycle units shall have a heat rate of 7605 Btu/kW-hr



(LHV) or lower LSC conditions without duct burner firing
to achieve
a design thermal efficiency of 57.4% (LHV).

Within 90 days of start up of the facility and on an
annual basis
hereafter, the owner or operator shall conduct a
Department-approved
heat rate performance test on a combined cycle unit while
it is
operating at maximum load to determine heat rate.

The owner or operator shall conduct this heat rate
performance test
according to the requirements of the American Society of
Mechanical
Engineers Performance Test Code on Overall Plant
Performance, ASME PTC
46-1996.

Parameter Monitored: HEAT RATE
Upper Permit Limit: 7605 BTU per kilowatt-hour
Reference Test Method: ASME PTC 46-1996
Monitoring Frequency: ANNUALLY
Averaging Method: MAXIMUM - NOT TO EXCEED STATED VALUE
SEE MONITORING DESCRIPTION
Reporting Requirements: SEMI-ANNUALLY (CALENDAR)
Reports due 30 days after the reporting period.
The initial report is due 1/30/2014.
Subsequent reports are due every 6 calendar month(s).

Condition 20: Compliance Demonstration
Effective between the dates of 08/01/2013 and 07/31/2018.

Applicable Federal Requirement: 6 NYCRR 231-7.6

Item 20.1:
The Compliance Demonstration activity will be performed for the facility:
The Compliance Demonstration applies to:

Emission Unit: U-00001

Emission Unit: U-00002

Emission Unit: U-00003

Emission Unit: U-00004

Emission Unit: U-00005

Emission Unit: U-00006



Item 20.2:

Compliance Demonstration shall include the following monitoring:

Monitoring Type: RECORD KEEPING/MAINTENANCE PROCEDURES
Monitoring Description:

The owner or operators of the facility shall calculate the annual emissions (based on a monthly rolling average) of Carbon Dioxide equivalent (CO₂e) emitted from the facility.

The Emissions factors will be based on either performance tests (as required by the permit) or developed emission factors from authorized sources (i.e. - AP-42). Fuel usage shall be monitored by fuel flow meters. The information will be kept on-site and available for review for a minimum of five years.

The facility will maintain records on-site for a minimum of five years.

Reference Test Method: As Described in condition

Monitoring Frequency: MONTHLY

Averaging Method: ANNUAL TOTAL ROLLED MONTHLY

Reporting Requirements: SEMI-ANNUALLY (CALENDAR)

Reports due 30 days after the reporting period

The initial report is due 1/30/2014

Subsequent reports are due every 6 calendar month(s).

Condition 21: Compliance Demonstration
Effective between the dates of 08/01/2013 and 07/31/2018

Applicable Federal Requirement: 6 NYCRR 231-7.6

Item 21.1:

The Compliance Demonstration activity will be performed for the facility:
The Compliance Demonstration applies to:

Emission Unit U-000001

Emission Unit U-000002

Item 21.2:

Compliance Demonstration shall include the following monitoring:

Monitoring Type: RECORD KEEPING/MAINTENANCE PROCEDURES
Monitoring Description:



The facility shall install, calibrate, maintain and operate a continuous emission monitor for the total annual Carbon Dioxide equivalent (CO₂e) emissions from the two combined cycle units.
The facility shall maintain records on-site for a minimum of five years.

Reference Test Method: 3A
Monitoring Frequency: CONTINUOUS
Averaging Method: ANNUAL TOTAL ROLLED MONTHLY
Reporting Requirements: SEMI-ANNUALLY (CALENDAR)
Reports due 30 days after the reporting period.
The initial report is due 1/30/2014.
Subsequent reports are due every 6 calendar month(s).

Condition 22: Compliance Demonstration
Effective between the dates of 08/01/2013 and 07/31/2018.

Applicable Federal Requirement(s) NYCRR 231-7.6

Item 22.1:
The Compliance Demonstration activity will be performed for the facility:

Regulated Contaminant(s):
C.A.S No: 007446-09-5 SULFUR DIOXIDE

Item 22.2:
Compliance Demonstration shall include the following monitoring:

Monitoring Type: WORK PRACTICE INVOLVING SPECIFIC OPERATIONS

Monitoring Description:
BACT FUEL SULFUR LIMIT OF 0.0015% BY WEIGHT.

Work Practice Type: PARAMETER OF PROCESS MATERIAL
Process Material: FUEL OIL
Parameter Monitored: SULFUR CONTENT
Upper Permit Limit: 0.0015 percent by weight
Reference Test Method: ASTM D-2880-71
Monitoring Frequency: PER DELIVERY
Averaging Method: MAXIMUM - NOT TO BE EXCEEDED AT ANY TIME (INSTANTANEOUS/DISCRETE OR GRAB)

Reporting Requirements: QUARTERLY (CALENDAR)
Reports due 30 days after the reporting period.
The initial report is due 10/30/2013.
Subsequent reports are due every 3 calendar month(s).

Condition 23: Compliance Demonstration



Effective between the dates of 08/01/2013 and 07/31/2018

Applicable Federal Requirement: 6 NYCRR 231-7.6

Item 23.1:

The Compliance Demonstration activity will be performed for the facility:
The Compliance Demonstration applies to:

Emission Unit: U-00001

Process: P1A

Emission Unit: U-00001

Process: P2A

Emission Unit: U-00002

Process: P01

Emission Unit: U-00002

Process: P02

Regulated Component(s)

CAS No. 00346-09-5 SULFUR DIOXIDE

Item 23.2:

Compliance Demonstration shall include the following monitoring:

Monitoring Type: INTERMITTENT EMISSION TESTING

Monitoring Description:

SO₂ is 0.0022 lb/MMBtu. Will be achieved through use of low sulfur fuels. Emission testing to be performed within 180 days of startup.

Upper Permit Limit: 0.0022 pounds per million Btu

Reference Test Method: EPA Approved

Monitoring Frequency: SINGLE OCCURRENCE

Averaging Method: HOUR AVERAGE

Reporting Requirements: ONCE / BATCH OR MONITORING OCCURRENCE

Condition 24: Compliance Demonstration

Effective between the dates of 08/01/2013 and 07/31/2018

Applicable Federal Requirement: 6 NYCRR 231-7.6

Item 24.1:

The Compliance Demonstration activity will be performed for the facility:
The Compliance Demonstration applies to:

Emission Unit: U-00001

Process: P1A

Emission Unit: U-00001



Process: P2A

Emission Unit: U-00001

Process: P01

Emission Unit: U-00002

Process: P02

Regulated Contaminant(s):

CAS No: 007864-93-9 SULFURIC ACID

Item 24.2:

Compliance Demonstration shall include the following monitoring:

Monitoring Type: INTERMITTENT EMISSION TESTING

Monitoring Description:

BACT is 0.0007 lb/mmBtu. Will be achieved through use of low sulfur fuels. Emission testing to be performed within 180 days of startup.

Upper Permit Limit: 0.0007 pounds per million Btu

Reference Test Method: EPA Approved

Monitoring Frequency: SINGLE OCCURRENCE

Averaging Method: 1-HOUR AVERAGE

Reporting Requirements: ONCE / BATCH OR MONITORING OCCURRENCE

Condition 25: Compliance Demonstration

Effective between the dates of 08/01/2013 and 07/31/2018

Applicable Federal Requirement: 6 NYCRR 251-7.6

Item 25.1:

The Compliance Demonstration activity will be performed for the facility.

The Compliance Demonstration applies to:

Emission Unit: U-00001

Process: P2A

Emission Unit: U-00002

Process: P02

Regulated Contaminant(s):

CAS No: 007864-93-9 SULFURIC ACID

Item 25.2:

Compliance Demonstration shall include the following monitoring:

Monitoring Type: INTERMITTENT EMISSION TESTING

Monitoring Description:

BACT is 0.0005 lb/mmBtu. Will be achieved through use of low sulfur fuels. Emission testing to be performed within



180 days of startup.

Upper Permit Limit: 0.0005 pounds per million Btus
Reference Test Method: EPA Approved
Monitoring Frequency: SINGLE OCCURRENCE
Averaging Method: 1-HOUR AVERAGE
Reporting Requirements: ONCE / BATCH OR MONITORING OCCURRENCE

Condition 26: Compliance Demonstration
Effective between the dates of 08/01/2013 and 07/31/2018

Applicable Federal Requirement: 6 NYCRR 231-7.6

Item 26.1:
The Compliance Demonstration activity will be performed for the facility:
The Compliance Demonstration applies to:

Emission Unit: U-00001
Process: P5a

Emission Unit: U-00002
Process: P1G

Regulated Contaminant(s)
C.S. No: 007446-09-5 SULFUR DIOXIDE

Item 26.2:
Compliance Demonstration shall include the following monitoring:

Monitoring Type: INTERMITTENT EMISSION TESTING
Monitoring Description:
EACT is 0.0015 lb/mmBtu. Will be achieved through use of
low sulfur fuels. Emission testing to be performed within
180 days of startup.

Upper Permit Limit: 0.0015 pounds per million Btus
Reference Test Method: EPA Approved
Monitoring Frequency: SINGLE OCCURRENCE
Averaging Method: 1-HOUR AVERAGE
Reporting Requirements: ONCE / BATCH OR MONITORING OCCURRENCE

Condition 27: Compliance Demonstration
Effective between the dates of 08/01/2013 and 07/31/2018

Applicable Federal Requirement: 6 NYCRR 231-7.6

Item 27.1:
The Compliance Demonstration activity will be performed for the facility:
The Compliance Demonstration applies to:



Emission Unit: U-00001
Process: P3A

Emission Unit: U-00002
Process: P03

Regulated Contaminant(s):
CAS No: 697075-00-0 PARTICULATES
CAS No: 697075-00-5 PM-10

Item 27.2:
Compliance Demonstration shall include the following monitoring:

Monitoring Type: INTERMITTENT EMISSION TESTING
Monitoring Description:

BACT is 0.0369 lb/mmBtu. Will be achieved through use of low sulfur fuels. Emission testing to be performed within 180 days of startup.

Upper Permit Limit: 0.0366 pounds per million Btu
Reference Test Method: Methods 301/201A and 307
Monitoring Frequency: SINGLE OCCURRENCE
Averaging Method: 1-HOUR AVERAGE
Reporting Requirements: ONCE / BATCH OR MONITORING OCCURRENCE

Condition 28: Compliance Demonstration
Effective between the dates of 08/01/2013 and 07/31/2018

Applicable Federal Requirement: 6 NYCRR 231-7.6

Item 28.1:
The Compliance Demonstration activity will be performed for the facility.
The Compliance Demonstration applies to:

Emission Unit: U-00001
Process: P2A

Emission Unit: U-00002
Process: P03

Regulated Contaminant(s):
CAS No: 000630-08-01 CARBON MONOXIDE

Item 28.2:
Compliance Demonstration shall include the following monitoring:

Monitoring Type: CONTINUOUS EMISSION MONITORING (CEM)
Monitoring Description:

BACT is 3.4 ppmvd corrected to 15% Oxygen. Will be achieved through good combustion controls and an oxidation catalyst.



The facility shall install, calibrate, maintain and operate a continuous emission monitor.

The limit applies at all loads except during start up and shutdown.

Manufacturer/Name/Model Number: CO analyzer
Parameter Monitored: CONCENTRATION
Upper Permit Limit: 3.4 parts per million by volume
(dry, corrected to 15% O₂)
Reference Test Method: Method 10
Monitoring Frequency: CONTINUOUS
Averaging Method: 1-HOUR AVERAGE
Reporting Requirements: QUARTERLY (CALENDAR)
Reports due 10 days after the reporting period.
The initial report is due 10/30/2013.
Subsequent reports are due every 3 calendar month(s).

Condition 29: Compliance Demonstration
Effective between the dates of 08/01/2013 and 07/31/2018.

Applicable Federal Requirements: NYCRR 231-7.6

Item 29.1:
The Compliance Demonstration activity will be performed for the facility.
The Compliance Demonstration applies to:

Emission Unit: U-00001
Process: P1A

Emission Unit: U-00001
Process: P2A

Emission Unit: U-00001
Process: P01

Emission Unit: U-00002
Process: P02

Regulated Contaminant(s):
CAS No: 00000-00-0 PARTICULATES
CAS No: 00000-00-5 PM-10

Item 29.2:
Compliance Demonstration shall include the following monitoring:

Monitoring Type: INTERMITTENT EMISSION TESTING
Monitoring Description:

BACT is 0.0073 lb/mmBtu. Will be achieved through use of low sulfur fuels. Emission testing to be performed within 180 days of startup.



Upper Permit Limit: 0.0073 pounds per million Btus
Reference Test Method: Methods 201/201A and 202
Monitoring Frequency: SINGLE OCCURRENCE
Averaging Method: 1-HOUR AVERAGE
Reporting Requirement: ONCE BATCH OR MONITORING OCCURRENCE

Condition 30: Compliance Demonstration
Effective between the dates of 08/01/2013 and 07/31/2018

Applicable Federal Requirement: 6 NYCRR 351-7.6

Item 30.1:

The Compliance Demonstration activity will be performed for the facility:
The Compliance Demonstration applies to:

Emission Unit: U-00001
Process: P1a

Emission Unit: U-00001
Process: P3a

Emission Unit: U-00002
Process: B01

Emission Unit: U-00002
Process: P03

Regulated Contaminant(s):
CAS No: 000830-08-0 CARBON MONOXIDE

Item 30.2:

Compliance Demonstration shall include the following monitoring:

Monitoring Type: CONTINUOUS EMISSION MONITORING (CEM)

Monitoring Description:

BACT is 2.0 ppmvd corrected to 15% Oxygen. Will be achieved through good combustion controls and an oxidation catalyst.

The facility shall install, calibrate, maintain, and operate a continuous emission monitor.

The firm applies at all times except during start up and shutdown.

Manufacturer Name/Model Number: CO analyzer
Parameter Monitored: CONCENTRATION
Upper Permit Limit: 2.0 parts per million by volume
(dry, corrected to 15% O₂)
Reference Test Method: Method 10



Monitoring Frequency: CONTINUOUS
Averaging Method: 1-HOUR AVERAGE
Reporting Requirements: QUARTERLY (CALENDAR)
Reports due 30 days after the reporting period.
The initial report is due 10/30/2013.
Subsequent reports are due every 3 calendar month(s)

Condition 31: Permit Requirements
Effective between the dates of 08/01/2013 and 07/31/2018

Applicable Federal Requirements: NYCRR 243-1.6 (a)

Item 31.1:

The CAIR designated representative of each CAIR NOx Ozone Season source shall
(i) submit to the department a complete CAIR permit application under section 243-3.3 in accordance with the deadlines specified in section 243-3.2; and
(ii) submit in a timely manner any supplemental information that the department determines to be necessary in order to review a CAIR permit application and issue or deny a CAIR permit.

The owners and operators of each CAIR NOx Ozone Season source shall have a CAIR permit issued by the department under Subpart 243-3 for the source and operate the source and the unit in compliance with such CAIR permit.

Condition 32: Monitoring requirements
Effective between the dates of 08/01/2013 and 07/31/2018

Applicable Federal Requirements: NYCRR 243-1.6 (b)

Item 32.1:

The emissions measurements recorded and reported in accordance with Subpart 243-5 shall be used to determine compliance by each CAIR NOx Ozone Season source with the CAIR NOx Ozone Season emissions limitation under subdivision (y) of this section.

Condition 33: NOx Ozone Season Emission Requirements
Effective between the dates of 08/01/2013 and 07/31/2018

Applicable Federal Requirements: NYCRR 243-1.6 (c)

Item 33.1:

As of the allowance transfer deadline for a control period, the owners and operators of each CAIR NOx Ozone Season source and each CAIR NOx Ozone Season unit at the source shall hold, in the source's compliance account, CAIR NOx Ozone Season allowances available for compliance deductions for the control period under section 243-6.3(a) in an amount not less than the tons of total nitrogen oxides emissions for the control period from all CAIR NOx Ozone Season units at the source, as determined in accordance with Subpart 243-8. The CAIR NOx ozone season is the period beginning May 1 of a calendar year, except as provided in section 243-1.6(c)(2), and ending on September 30 of the same year, inclusive.

A CAIR NOx Ozone Season unit shall be subject to the requirements under paragraph (c)(1) of this section for the control period starting on the later of May 1, 2009 or the deadline for meeting the unit's monitor certification requirements under sections 243-8.1(b)(1), (2), (3), or (7) and for



each control period thereafter.

A CAIR/NOx Ozone Season allowance shall not be deducted for compliance with the requirements under paragraph (c) (1) of this section for a control period in a calendar year before the year for which the CAIR/NOx Ozone Season allowance was allocated.

CAIR/NOx Ozone Season allowances shall be held or deducted from or transferred into or among CAIR/NOx Ozone Season Allowance Trading System accounts in accordance with Subparts 243-6, 243-7, and 243-9.

A CAIR/NOx Ozone Season allowance is a limited authorization to emit one ton of nitrogen oxides in accordance with the CAIR/NOx Ozone Season Trading Program. No provision of the CAIR/NOx Ozone Season Trading Program, the CAIR permit application, the CAIR permit, or an exemption under section 243-1.5 and no provision of law shall be construed to limit the authority of the State of the United States to terminate or limit such authorization.

A CAIR/NOx Ozone Season allowance does not constitute a property right.

Upon recording by the Administrator under Subpart 243-6, 243-7, or 243-9, every allocation, transfer, or deduction of a CAIR/NOx Ozone Season allowance to or from a CAIR/NOx Ozone Season source's compliance account is incorporated automatically in any CAIR permit of the source.

Condition 34: Excess emission requirements
Effective between the dates of 08/01/2013 and 07/31/2018

Applicable Federal Requirement: 6 NYCRR 243-1.6 (d)

Item 34.1:

If a CAIR/NOx Ozone Season source emits nitrogen oxides during any control period in excess of the CAIR/NOx Ozone Season emissions limitation, then:

(1) the owners and operators of the source and each CAIR/NOx Ozone Season unit at the source shall surrender the CAIR/NOx Ozone Season allowances required for deduction under section 243-6.5(d)(1) and pay any fine, penalty, or assessment or comply with any other remedy imposed, for the same violations, under the Act or applicable State law; and

(2) each ton of such excess emissions and each day of such control period shall constitute a separate violation of this Subpart, the Act, and applicable State law.

Condition 35: Recordkeeping and reporting requirements
Effective between the dates of 08/01/2013 and 07/31/2018

Applicable Federal Requirement: 6 NYCRR 243-1.6 (e)

Item 35.1:

Unless otherwise provided, the owners and operators of the CAIR/NOx Ozone Season source and each CAIR/NOx Ozone Season unit at the source shall keep on site at the source each of the following documents for a period of five years from the date the document is created. This period may be extended for cause, at any time before the end of five years, in writing by the department or the Administrator.



(r) The certificate of representation under section 243-2.4 for the CAIR designated representative for the source and each CAIR NOx Ozone Season unit at the source and all documents that demonstrate the truth of the statements in the certificate of representation; provided that the certificate and documents shall be retained on site at the source beyond such five-year period until such documents are superseded because of the submission of a new certificate of representation under section 243-2.4 changing the CAIR designated representative.

(s) All emissions monitoring information, in accordance with Subpart 243-8, provided that to the extent that Subpart 243-8 provides for a three-year period for recordkeeping, the three-year period shall apply.

(t) Copies of all reports, compliance certifications, and other submissions and all records made or required under the CAIR NOx Ozone Season Trading Program.

(v) Copies of all documents used to complete a CAIR permit application and any other submission under the CAIR NOx Ozone Season Trading Program to demonstrate compliance with the requirements of the CAIR NOx Ozone Season Trading Program.

Condition 36: Authorization and responsibilities of CAIR designated representative
Effective between the dates of 08/01/2013 and 07/31/2018.

Applicable Federal Requirement: 6 NYCRR 243-2.1

Item 36.1:

Except as provided under section 243-2.2, each CAIR NOx Ozone Season source, including all CAIR NOx Ozone Season units at the source, shall have one and only one CAIR designated representative, with regard to all matters under the CAIR NOx Ozone Season Trading Program concerning the source or any CAIR NOx Ozone Season unit at the source.

The CAIR designated representative of the CAIR NOx Ozone Season source shall be selected by an agreement binding on the owners and operators of the source and all CAIR NOx Ozone Season units at the source and shall act in accordance with the certification statement in section 243-2.4(a)(1)(v).

Upon receipt by the Administrator of a complete certificate of representation under section 243-2.4, the CAIR designated representative of the source shall represent and, by his or her representations, actions, inactions, or submissions, legally bind each owner and operator of the CAIR NOx Ozone Season source represented and each CAIR NOx Ozone Season unit at the source in all matters pertaining to the CAIR NOx Ozone Season Trading Program, notwithstanding any agreement between the CAIR designated representative and such owners and operators. The owners and operators shall be bound by any decision or order issued to the CAIR designated representative by the department, the Administrator, or a court regarding the source or unit.

No CAIR permit will be issued, no emissions data reports will be accepted, and no CAIR NOx Ozone Season Allowance Tracking System account will be established for a CAIR NOx Ozone Season unit at a source, until the Administrator has received a complete certificate of representation under section 243-2.4 for a CAIR designated representative of the source and the CAIR NOx Ozone Season units at the source.

Each submission under the CAIR NOx Ozone Season Trading Program shall be submitted,



signed, and certified by the CAIR designated representative for each CAIR NOx Ozone Season source on behalf of which the submission is made. Each such submission shall include the following certification statement by the CAIR designated representative: "I am authorized to make this submission on behalf of the owners and operators of the source or units for which the submission is made. I certify under penalty of law that I have personally examined, and am familiar with, the statements and information submitted in this document and all its attachments. Based on my inquiry of those individuals with primary responsibility for obtaining the information, I certify that the statements and information are to the best of my knowledge and belief true, accurate, and complete. I am aware that there are significant penalties for submitting false statements and information or omitting required statements and information, including the possibility of fine or imprisonment."

Condition 37: Certificate of representation
Effective between the dates of 09/01/2013 and 07/31/2018

Applicable Federal Requirement: 6 NYCRR 243-2.4

Item 37.1:

Unless otherwise required by the department or the Administrator, documents of agreement referred to in the certificate of representation shall not be submitted to the department or the Administrator. Neither the department nor the Administrator shall be under any obligation to review or evaluate the sufficiency of such documents, if submitted.

Condition 38: General requirements
Effective between the dates of 08/01/2013 and 07/31/2018

Applicable Federal Requirement: 6 NYCRR 243-8.1

Item 38.1:

The owners and operators, and to the extent applicable, the CAIR designated representative, of a CAIR NOx Ozone Season unit shall comply with the monitoring, recordkeeping, and reporting requirements as provided in this Subpart and in Subpart H of 40 CFR Part 75. For purposes of complying with such requirements, the definitions in section 243-1.2 and in 40 CFR 75.2 shall apply and the terms "affected unit," "designated representative," and "continuous emission monitoring system" (or "CEMS") in 40 CFR Part 75 shall be deemed to refer to the terms "CAIR NOx Ozone Season unit," "CAIR designated representative," and "continuous emission monitoring system" (or "CEMS") respectively, as defined in section 243-1.3. The owner or operator of a unit that is not a CAIR NOx Ozone Season unit but that is monitored under 40 CFR 75.70(b)(1)(i) shall comply with the same monitoring, recordkeeping, and reporting requirements as a CAIR NOx Ozone Season unit.

Requirements for installation, certification, and data accounting. The owner or operator of each CAIR NOx Ozone Season unit shall:

- (1) install all monitoring systems required under this Subpart for monitoring NOx mass emissions and individual unit heat input (including all systems required to monitor NOx emission rate, NOx concentration, stack gas moisture content, stack gas flow rate, CO₂ or O₂ concentration, and fuel flow rate, as applicable, in accordance with 40 CFR 75.71 and 40 CFR 75.72);
- (2) successfully complete all certification tests required under section 243-8.2 and meet all other requirements of this Subpart and 40 CFR Part 75 applicable to the monitoring systems under



paragraph (d)(1) of this section; and

(3) record, report, and quality assure the data from the monitoring systems under paragraph (d)(1) of this section.

Condition 39: Prohibitions

Effective between the dates of 08/01/2013 and 07/31/2018

Applicable Federal Requirement (6 NYCRR 243-8.1)

Item 39.1:

No owner or operator of a CAIR NOx Ozone Season unit shall use any alternative monitoring system, alternative reference method, or any other alternative to any requirement of this Subpart without having obtained prior written approval in accordance with section 243-8.6.

No owner or operator of a CAIR NOx Ozone Season unit shall operate the unit so as to discharge, or allow to be discharged, NOx emissions to the atmosphere without accounting for all such emissions in accordance with the applicable provisions of this Subpart and 40 CFR Part 75.

No owner or operator of a CAIR NOx Ozone Season unit shall disrupt the continuous emission monitoring system, any portion thereof, or any other approved emission monitoring method, and thereby avoid monitoring and recording NOx mass emissions discharged into the atmosphere by that unit, except for periods of recertification or periods when calibration, quality assurance testing, or maintenance is performed in accordance with the applicable provisions of this Subpart and 40 CFR Part 75.

No owner or operator of a CAIR NOx Ozone Season unit shall retire or permanently discontinue any of the continuous emission monitoring system, any component thereof, or any other approved monitoring system under this Subpart, except under any one of the following circumstances:

- (i) during the period that the unit is covered by an exemption under section 243-1.5 that is in effect;
- (ii) the owner or operator is monitoring emissions from the unit with another certified monitoring system approved in accordance with the applicable provisions of this Subpart and 40 CFR Part 75, by the department for use at that unit that provides emission data for the same pollutant or parameter as the retired or discontinued monitoring system; or
- (iii) the CAIR designated representative submits notification of the date of certification testing of a replacement monitoring system for the retired or discontinued monitoring system in accordance with section 243-8.2(d)(3)(i).

Condition 40: Quarterly reports

Effective between the dates of 08/01/2013 and 07/31/2018

Applicable Federal Requirement (6 NYCRR 243-8.5 (d))

Item 40.1:

The CAIR designated representative shall submit quarterly reports, as follows:

If the CAIR NOx Ozone Season unit is subject to an Acid Rain emissions limitation or a CAIR NOx emissions limitation or if the owner or operator of such unit chooses to report on an annual basis under this Subpart, the CAIR designated representative shall meet the requirements of



Subpart H of 40 CFR Part 75 (concerning monitoring of NOx mass emissions) for such unit for the entire year and shall report the NOx mass emissions data and heat input data for such unit, in an electronic quarterly report in a format prescribed by the Administrator, for each calendar quarter beginning with:

(1) for a unit that commences commercial operation before July 1, 2007, the calendar quarter covering May 1, 2008 through June 30, 2008;

(2) for a unit that commences commercial operation on or after July 1, 2007, the calendar quarter corresponding to the earlier of the date of provisional certification or the applicable deadline for final certification under section 245-6.3(b), unless that quarter is the third or fourth quarter of 2007 or the first quarter of 2008, in which case reporting shall commence in the quarter covering May 1, 2008 through June 30, 2008.

The CAIR designated representative shall submit each quarterly report to the Administrator within 30 days following the end of the calendar quarter covered by the report. Quarterly reports shall be submitted in the manner specified in 40 CFR 75.73(d).

For CAIR NOx Ozone Season units that are also subject to an Acid Rain emissions limitation or the CAIR NOx Annual Trading Program, CAIR SO₂ Trading Program, or the Mercury Reduction Program for Coal-Fired Electric Utility Steam Generating Units (6 NYCRR Part 240), quarterly reports shall include the applicable data and information required by Subparts F through I of 40 CFR Part 75 as applicable, in addition to the NOx mass emission data, heat input data, and other information required by this Subpart.

Condition 41: Compliance certification

Effective between the dates of 08/01/2013 and 07/31/2018

Applicable Federal Requirement 6 NYCRR 243-8.5 (c)

Item 41.1:

The CAIR designated representative shall submit to the Administrator a compliance certification (in a format prescribed by the Administrator) in support of each quarterly report based on reasonable inquiry of those persons with primary responsibility for ensuring that all of the unit's emissions are correctly and fully monitored. The certification shall state that:

(1) the monitoring data submitted were recorded in accordance with the applicable requirements of this Subpart and 40 CFR Part 75, including the quality assurance procedures and specifications;

(2) for a unit with add-on NOx emission controls and for all hours where NOx data are submitted in accordance with 40 CFR 75.94(a)(1), the add-on emission controls were operated within the range of parameters listed in the quality assurance/quality control program under appendix B to 40 CFR Part 75 and the substitute data values do not systematically underestimate NOx emissions; and

(3) for a unit that is reporting on a control period basis under subparagraph (d)(2)(ii) of this section, the NOx emission rate and NOx concentration values substituted for missing data under Subpart D of 40 CFR Part 75 are calculated using only values from a control period and do not systematically underestimate NOx emissions.

Condition 42: CAIR NOx Annual Trading Program General Conditions



Effective between the dates of 08/01/2013 and 07/31/2018

Applicable Federal Requirement:6 NYCRR Subpart 244-1

Item 42.1:

1) As of midnight of March 1, or midnight of the first business day thereafter if March 1 is not a business day, the owners and operators shall hold, in their compliance account, Clean Air Interstate Rule (CAIR) NOx allowances available for compliance deductions for the previous control period (January 1 through December 31), in an amount not less than the total tons of nitrogen oxides emissions from all CAIR NOx units at the source during that control period. A CAIR NOx allowance shall not be deducted for a control period in a calendar year before the year for which the CAIR NOx allowance was allocated. [244-1.6(c)(1), 244-1.2(b)(5), 244-1.2(b)(36), 244-1.6(c)(3)]

2) The owners and operators shall hold in their compliance account, CAIR NOx allowances available for compliance deductions for the control period starting on the later of January 1, 2009 or the deadline for meeting a CAIR NOx unit's monitor certification requirements under section 244-8.1(b)(1), (2), or (5) and for each control period thereafter. [244-1.6(c)(2)]

3) If a CAIR NOx source emits nitrogen oxides during any control period in excess of the CAIR NOx emissions limitation, the owners and operators of the CAIR NOx source shall surrender the CAIR NOx allowances required for deduction under 6NYCRR Part 244-6.5(d)(1) and pay any fine, penalty, or assessment or comply with any other remedy imposed, for the same violations, under the Act or applicable State law. Each ton of such excess emissions and each day of such control period shall constitute a separate violation of this permit, the Act, and applicable State law. [(244-1.6(d)]

4) Unless otherwise provided, the owners and operators of the CAIR NOx source shall keep on site each of the following documents for a period of five years from the date the document is created. This period may be extended for cause, at any time before the end of five years, in writing by the department or the Administrator: [244-1.6(e)]

(i) The certificate of representation under 6NYCRR Part 244-2.4 for the CAIR designated representative for the source and all documents that demonstrate the truth of the statements in the certificate of representation; provided that the certificate and documents shall be retained on site at the source beyond such five year period until such documents are superseded because of the submission of a new certificate of representation under 6NYCRR Part 244-2.4 changing the CAIR designated representative.

(ii) All emissions monitoring information, in accordance with 6NYCRR Part 244-8, provided that to the extent that 6NYCRR Part 244-8 provides for a three year period for recordkeeping, the three year period shall apply.

(iii) Copies of all reports, compliance certifications, and other submissions and all records made or required under the CAIR NOx Annual Trading Program

(iv) Copies of all documents used to complete a CAIR permit application and any other submission under the CAIR NOx Annual Trading Program or to demonstrate compliance with the requirements of the CAIR NOx Annual Trading Program

Condition 43: Designated CAIR Representative
Effective between the dates of 08/01/2013 and 07/31/2018

Applicable Federal Requirement:6 NYCRR Subpart 244-2

Item 43.1:



(1) Each Clean Air Interstate Rule (CAIR) NOx source shall have one CAIR designated representative and may have one alternate representative, as per 6NYCRR Part 244-2.2, with regard to all matters under the CAIR NOx Annual Trading Program. The CAIR designated representative shall be selected by an agreement binding on the owners and operators of the source and act in accordance with the certification statement in 6NYCRR Part 244-2.4(c)-(d)(v). Upon receipt by the Administrator of a complete certificate of representation under 6NYCRR Part 244-2.4, the CAIR designated representative of the source shall represent and, by his or her representative actions, motions, or submissions, legally bind each owner and operator of the CAIR NOx source represented in all matters pertaining to the CAIR NOx Annual Trading Program, notwithstanding any agreement between the CAIR designated representative and such owners and operators. The owners and operators shall be bound by any decision or order issued to the CAIR designated representative by the department, the Administrator, or a court regarding the source. [244-2.1(a), (b), & (c)]

(2) Each submission under the CAIR NOx Annual Trading Program shall be submitted, signed, and certified by the CAIR designated representative for each CAIR NOx source on behalf of which the submission is made. Each such submission shall include the following certification statement by the CAIR designated representative: "I am authorized to make this submission on behalf of the owners and operators of the source or units for which the submission is made. I verify under penalty of law that I have personally examined, and am familiar with, the statements and information submitted in this document and all its attachments. Based on my inquiry of those individuals with primary responsibility for obtaining the information, I certify that the statements and information are to the best of my knowledge and belief true, accurate, and complete. I am aware that there are significant penalties for submitting false statements and information or omitting required statements and information, including the possibility of fine or imprisonment." [244-2.1(e)]

Condition 44: Compliance Demonstration
Effective between the dates of 08/01/2013 and 07/31/2018

Applicable Federal Requirement: 6 NYCRR Subpart 244-8

Item 44.1:
The Compliance Demonstration activity will be performed for the facility

Regulated Contaminant(s):
CAS No.: 00000000 OXIDES OF NITROGEN

Item 44.2:
Compliance Demonstration shall include the following monitoring:

Monitoring Type: RECORD KEEPING/MAINTENANCE PROCEDURES
Monitoring Description:
Monitoring and Reporting NOx emissions

(1) The owners and operators, and to the extent applicable, the CAIR designated representative shall comply with all recordkeeping and reporting requirements in this condition, the applicable recordkeeping and reporting requirements under 40 CFR 75, and the requirements of 6NYCRR Part 244-2.1(e)(1).



(2) The CAIR designated representative shall submit quarterly reports of the the NO_x mass emissions data and heat input data for each CAIR NO_x unit, in an electronic quarterly report in a format prescribed by the Administrator, for each calendar quarter beginning with the calendar quarter corresponding to the earlier of the date of provisional certification or the applicable deadline for initial certification under 6NYCRR Part 244.8.1(b), unless that quarter is the third or fourth quarter of 2007, in which case reporting shall commence in the quarter covering January 1, 2008 through March 31, 2008.

(3) The CAIR designated representative shall submit each quarterly report to the Administrator within 30 days following the end of the calendar quarter covered by the report. Quarterly reports shall be submitted in the manner specified in 40 CFR 75.73(d).

(4) For CAIR NO_x units that are also subject to an Acid Rain emissions limitation or the CAIR NO_x Ozone Season Trading Program, CAIR SO₂ Trading Program, or the Mercury Reduction Program for Coal-Fired Electric Utility Steam Generating Units (6NYCRR Part 246), quarterly reports shall include the applicable data and information required by Subparts F through J of 40 CFR Part 75 as applicable, in addition to the NO_x mass emission data, heat input data, and other information required by this Subpart.

(5) 'Compliance certification.' The CAIR designated representative shall submit to the Administrator a compliance certification (in a format prescribed by the Administrator) in support of each quarterly report based on reasonable inquiry of those persons with primary responsibility for ensuring that all of the unit's emissions are correctly and fully monitored. The certification shall state that

(i) the monitoring data submitted were recorded in accordance with the applicable requirements of 6NYCRR Part 244 and 40 CFR Part 75, including the quality assurance procedures and specifications; and

(ii) for a unit with add-on NO_x emission controls and for all hours where NO_x data are substituted in accordance with 40 CFR 75.34(a)(1), the add-on emission controls were operating within the range of parameters listed in the quality assurance/quality control program under appendix B to 40 CFR Part 75 and the substitute data values do not systematically underestimate NO_x emissions.



(6) Whenever any monitoring system fails to meet the quality-assurance and quality-control requirements or data validation requirements of 40 CFR part 75, data shall be substituted using the applicable missing data procedures in Subpart D or Subpart E of, or appendix D or appendix E to 40 CFR part 75. [244-8.3(a)]

(7) Whenever the owner or operator makes a replacement, modification, or change in any certified continuous emission monitoring system under 6 NYCRR Part 244-8.3(a)(1) that may significantly affect the ability of the system to accurately measure or record NOx mass emissions or heat input rate or to meet the quality-assurance and quality-control requirements of 40 CFR 75.21 or appendix B to 40 CFR Part 75, the owner or operator shall recertify the monitoring system in accordance with 40 CFR 75.20(b). Furthermore, whenever the owner or operator makes a replacement, modification, or change to the flue gas handling system or the unit's operation that may significantly change the stack flow or concentration profile, the owner or operator shall recertify each continuous emission monitoring system whose accuracy is potentially affected by the change, in accordance with 40 CFR 75.20(b). Examples of changes to a continuous emission monitoring system that require recertification include replacement of the analyzer, complete replacement of an existing continuous emission monitoring system, or change in location or orientation of the sampling probe or site. Any fuel flowmeter systems and any excepted NOx monitoring systems under appendix E to 40 CFR part 75, under 6 NYCRR Part 244-8.3(a)(1) are subject to the recertification requirements in 40 CFR 75.20(g)(6). [244-8.3(d)(2)]

Monitoring Frequency: CONTINUOUS
Averaging Method: ANNUAL TOTAL
Reporting Requirements: QUARTERLY (CALENDAR)
Reports due 30 days after the reporting period
The initial report is due 10/30/2013.
Subsequent reports are due every 3 calendar month(s).

Condition 45: CAIR SO₂ Trading Program General Provisions
Effective between the dates of 08/01/2013 and 07/31/2018

Applicable Federal Requirement: 6 NYCRR Subpart 245-1

Item 45.1:

1) As of midnight of March 1, or midnight of the first business day thereafter (if March 1 is not a business day) for a control period, the owners and operators of each Clean Air Interstate Rule (CAIR) SO₂ source shall hold, in the source's compliance account, a tonnage equivalent in CAIR SO₂ allowances available for compliance deductions for the control period (January 1



through December 31) not less than the tons of total sulfur dioxide emissions for the control period from all CAIR SO₂ units at the source. A CAIR SO₂ allowance shall not be deducted, for compliance with the requirements under paragraph (2) of this section, for a control period in a calendar year before the year for which the CAIR SO₂ allowance was allocated.

[(245-1.2(b)(5), 245-1.6(c)(1), 245-1.2(b)(36), 245-1.6(c)(3)]

2) The owners and operators shall hold in their compliance account, CAIR SO allowances available for compliance deductions for the control period starting on the later of January 1, 2010 or the deadline for meeting a CAIR SO₂ unit's monitor certification requirements under section 245-8.1(b)(1), (2), or (5) and for each control period thereafter. [245-1.6(c)(2)]

3) If a CAIR SO₂ source emits sulfur dioxide during any control period in excess of the CAIR SO₂ emissions limitation, the owners and operators of the source shall surrender the CAIR SO₂ allowances required for deduction under 6NYCRR Part 245-6.5(d)(1) and pay any fine, penalty, or assessment or comply with any other remedy imposed, for the same violations, under the Act or applicable State law. Each ton of such excess emissions and each day of such control period shall constitute a separate violation of this Subpart, the Act, and applicable State law.

[(245-1.6(d)]

4) Unless otherwise provided, the owners and operators of the CAIR SO₂ source shall keep on site at the source each of the following documents for a period of five years from the date the document is created. This period may be extended for cause, at any time before the end of five years, in writing by the department or the Administrator: [245-1.6(e)]

(i) The certificate of representation under 6NYCRR Part 245-2.4 for the CAIR designated representative for the source and all documents that demonstrate the truth of the statements in the certificate of representation; provided that the certificate and documents shall be retained on site at the source beyond such five-year period until such documents are superseded because of the submission of a new certificate of representation under 6NYCRR Part 245-2.4 changing the CAIR designated representative.

(ii) All emissions monitoring information, in accordance with 6NYCRR Part 245-8, provided that to the extent that 6NYCRR Part 245-8 provides for a three-year period for recordkeeping, the three-year period shall apply.

(iii) Copies of all reports, compliance certifications, and other submissions and all records made or required under the CAIR SO₂ Trading Program

(iv) Copies of all documents used to complete a CAIR permit application and any other submission under the CAIR SO₂ Trading Program or to demonstrate compliance with the requirements of the CAIR SO₂ Trading Program

Condition 46: Designated CAIR Representative
Effective between the dates of 08/01/2013 and 07/31/2018

Applicable Federal Requirement: 6 NYCRR Subpart 245-2

Item 46.1:

1) Each CAIR SO₂ source shall have one and only one CAIR designated representative and may have one alternate representative, as per 6NYCRR Part 245-2.2, with regard to all matters under the CAIR SO₂ Trading Program. The CAIR designated representative of the CAIR SO₂ source shall be selected by an agreement binding on the owners and operators of the source and all CAIR SO₂ units at the source and shall act in accordance with the certification statement in 6NYCRR Part 245-2.4(a)(4)(iv). Upon receipt by the Administrator of a complete certificate of representation under 6NYCRR Part 245-2.4, the CAIR designated representative of the source shall represent and, by his or her representations, actions, inactions, or submissions, legally bind



each owner and operator of the CAIR SO₂ source represented and each CAIR SO₂ unit of the source in all matters pertaining to the CAIR SO₂ Trading Program, notwithstanding any agreement between the CAIR designated representative and such owners and operators. The owners and operators shall be bound by any decision or order issued to the CAIR designated representative by the department, the Administrator, or a court regarding the source or unit [45-2.1(a), (b) & (c)]

(i) Each submission under the CAIR SO₂ Trading Program shall be submitted, signed, and certified by the CAIR designated representative for each CAIR SO₂ source on behalf of which the submission is made. Each such submission shall include the following certification statement by the CAIR designated representative: "I am authorized to make this submission on behalf of the owners and operators of the source or units for which the submission is made. I certify, under penalty of law that I have personally examined, and am familiar with, the statements and information submitted in this document and all its attachments. Based on my inquiry of those individuals with primary responsibility for obtaining the information, I certify that the statements and information are to the best of my knowledge and belief true, accurate, and complete. I am aware that there are significant penalties for submitting false statements and information or omitting required statements and information, including the possibility of fine or imprisonment. [45-2.1(b)]

Condition 47: Compliance Demonstration
Effective between the dates of 08/01/2013 and 07/31/2018
Applicable Federal Requirement: 6 NYCRR Subpart 245-8

Item 47.1:
The Compliance Demonstration activity will be performed for the Facility:

Regulated Contaminant(s):
CAS No: 007446-09-5 SULFUR DIOXIDE

Item 47.2:
Compliance Demonstration shall include the following monitoring:

Monitoring Type: RECORD KEEPING/MAINTENANCE PROCEDURES
Monitoring Description:

Maintaining and Reporting SO₂ emissions.

1) The owners and operators, and to the extent applicable, the Clean Air Interstate Rule (CAIR) designated representative, of a CAIR SO₂ unit, shall comply with the monitoring, recordkeeping, and reporting requirements as provided in Subpart 6 NYCRR Part 245-8 and in 40 CFR Part 5, Subparts F and G. For purposes of compliance with such requirements, the definitions in section 245-1.2 and 40 CFR 72.2 shall apply, and the terms "affected unit," "designated representative," and "continuous emission monitoring system" (or "CEMS") in 40 CFR Part 75 shall be deemed to refer to the terms "CAIR SO₂ unit," "CAIR designated representative," and "continuous emission monitoring system" (or "CEMS") respectively, as defined in section 245-1.2. The owner or operator of a unit that is



not a CAIR SO₂ unit that unit is monitored under 40 CFR 75.16(b)(2) shall comply with the same monitoring, recordkeeping, and reporting requirements as a CAIR SO₂ unit. [245-8.1]

2) The owner or operator of each CAIR SO₂ unit shall [245-8.1(a)]

(i) install all monitoring systems required under this Subpart for monitoring SO₂ mass emissions and individual unit heat input (including all systems required to measure SO₂ concentration, stack gas moisture content, stack gas flow rate, CO₂ or O₂ concentration, and fuel flow rate, as applicable, in accordance with 40 CFR 75.11 and 40 CFR 75.16);

(ii) successfully complete all certification tests required under Part 245-8.2 and meet all other requirements of this section and 40 CFR Part 75 applicable to the monitoring systems under this section; and

(iii) record, report, and quality-assure the data from the monitoring systems under paragraph of this section.

3) The owner or operator shall meet the monitoring system certification and other requirements of section 245-8.16(a)(1) and (2) on or before the following dates. The owner or operator shall record, report, and quality-assure the data from the monitoring systems under section 245-8.16(a)(1) on and after the following dates [245-8.1(b)]

(i) For the CAIR SO₂ unit that commences commercial operation before July 1, 2008, by January 1, 2009;

(ii) For the CAIR SO₂ unit that commences commercial operation on or after July 1, 2008, by the later of the following dates: January 1, 2009; or 90 unit operating days or 180 calendar days, whichever occurs first, after the date on which the unit commences commercial operation.

4) Whenever the owner or operator makes a replacement, modification, or change in any certified continuous emission monitoring system under section 245-8.1(a)(1) that may significantly affect the ability of the system to accurately measure or record SO₂ mass emissions or heat input rate or to meet the quality-assurance and quality control requirements of 40 CFR 75.21 or appendix II to 40 CFR Part 75, the owner or operator shall recertify the monitoring system in accordance with 40 CFR 75.20(b). Furthermore, whenever the owner or operator makes a replacement, modification, or change to the flue gas handling system or the unit's operation that may significantly change the stack flow or concentration profile, the owner or operator shall recertify each



continuous emission monitoring system whose accuracy is potentially affected by the change, in accordance with 40 CFR 75.20(b). Examples of changes to a continuous emission monitoring system that require recertification include: replacement of the analyzer, complete replacement of an existing continuous emission monitoring system, or change in location or orientation of the sampling probe or site. Any fuel flowmeter system under section 245-8.1(a)(1) is subject to the recertification requirements of 40 CFR 75.20(g)(6), [245-8.2(d)(2)].

5) Whenever any monitoring system fails to meet the quality-assurance and quality-control requirements or data-validation requirements of 40 CFR Part 75, data shall be submitted using the applicable missing data procedures in Subpart D of or appendix D to 40 CFR Part 75. [245-8.3(a)]

6) The CAIR designated representative shall comply with all recordkeeping and reporting requirements in section 245-8.3, the applicable recordkeeping and reporting requirements in Subparts F and G of 40 CFR Part 75, and the requirements of section 245-2.1(e)(1). [245-8.5(a)]

7) The owner or operator of a CAIR SO₂ unit shall comply with requirements of 40 CFR 75.62 for monitoring plans. [245-8.5(b)]

8) The CAIR designated representative shall submit an application to the department within 45 days after completing all initial certification or recertification tests required under section 245-8.2, including the information required under 40 CFR 75.63. [245-8.5(c)]

9) The CAIR designated representative shall submit quarterly reports of the SO₂ mass emissions data and heat input data for each CAIR SO₂ unit in an electronic quarterly report to a location prescribed by the Administrator, for each calendar quarter beginning with [245-8.5(d)(1)]

i) the calendar quarter covering January 1, 2009 through March 31, 2009 for a unit that commences commercial operation before July 1, 2008; or

ii) for a unit that commences commercial operation on or after July 1, 2008, the calendar quarter corresponding to the earlier of the date of provisional certification or the applicable deadline for initial certification under section 245-8.1(b), unless that quarter is the third or fourth quarter of 2008, in which case reporting shall commence in the quarter covering January 1, 2009 through



March 31, 2009:

(10) The CAIR designated representative shall submit each quarterly report to the Administrator within 30 days following the end of the calendar quarter covered by the report. Quarterly reports shall be submitted in the manner specified in 40 CFR 75.63 (245-8.5(d)(2)).

(11) For CAIR SO₂ units that are also subject to an Acid Rain emissions limitation or the CAIR NO_x Annual Trading Program, CAIR NO_x Ozone Season Trading Program, or the Mercury Reduction Program for Coal-Fired Electric Utility Steam Generating Units (6 NYCRR Part 246), quarterly reports shall include the applicable data and information required by Subparts F through I of 40 CFR Part 75 as applicable, in addition to the SO₂ mass emission data, heat input data, and other information required by this Subpart (245-8.5(d)(3)).

(12) The CAIR designated representative shall submit to the Administrator a compliance certification (in a format prescribed by the Administrator) in support of each quarterly report based on reasonable inquiry of those persons with primary responsibility for ensuring that all of the unit's emissions are correctly and fully monitored. The certification shall state that: (245-8.5(e))

- (i) the monitoring data submitted were recorded in accordance with the applicable requirements of this Subpart and 40 CFR Part 75, including the quality assurance procedures and specifications; and
- (ii) for a unit with add-on SO₂ emission controls and for all hours where SO₂ data are substituted in accordance with 40 CFR 75.33(a)(1), the add-on emission controls were operating within the range of parameters listed in the quality assurance/quality control program under appendix B to 40 CFR Part 75 and the substitute data values do not systematically underestimate SO₂ emissions.

Monitoring Frequency: CONTINUOUS
Averaging Method: ANNUAL TOTAL
Reporting Requirements: QUARTERLY (CALENDAR)
Reports due 30 days after the reporting period
The initial report is due 10/30/2013.
Subsequent reports are due every 3 calendar months.

Condition 48: EPA Region 2 address.
Effective between the dates of 08/01/2013 and 07/31/2018

Applicable Federal Requirement: 40CFR 60.4, NSPS Subpart A

Item 48.1:

All requests, reports, applications, submittals, and other communications to the Administrator



Documents to this part shall be submitted in duplicate to the following address:

Director, Division of Enforcement and Compliance Assistance
CERCLA Region 2
290 Broadway, 21st Floor
New York, NY 10007-1886

Copies of all correspondence to the administrator pursuant to this part shall also be submitted to the NYSDEC Regional Office issuing this permit (see address at the beginning of this permit) and to the following address:

NYSDEC
Bureau of Quality Assurance
625 Broadway
Albany, NY 12233-3259

**Condition 49: Date of construction notification - If a COM is not used.
Effective between the dates of 08/01/2013 and 07/31/2018**

Applicable Federal Requirement: 40CFR 60.7(a), NSPS Subpart A

Item 49.1:

Any owner or operator subject to this part shall furnish the Administrator with the following information:

- 1) a notification of the date construction or reconstruction commenced, post marked no later than 30 days after such date;
- 2) a notification of the actual date of initial start up, post marked within 15 days after such date;
- 3) a notification of any physical or operational change to an existing facility which may increase the emission rate of any air pollutant to which a standard applies, unless the change is specifically exempted under this part. The notice shall be post marked 60 days or as soon as practicable before the change is commenced and shall include information describing the precise nature of the change, present and proposed emission control systems, productive capability of the facility before and after the change, and the expected completion date of the change. The Administrator may request additional information regarding the change;
- 4) a notification of the date upon which the demonstration of continuous monitoring system performance commences, post marked not less than 30 days prior to such date;
- 5) a notification of the anticipated date for conducting the opacity observations, post marked not less than 30 days prior to such date.

**Condition 50: Recordkeeping requirements.
Effective between the dates of 08/01/2013 and 07/31/2018**

Applicable Federal Requirement: 40CFR 60.7(b), NSPS Subpart A

Item 50.1:

Affected owners or operators shall maintain records of occurrence and duration of any startup,



shutdown, or malfunction in the operation of an affected facility; any malfunction of the air pollution control equipment; or any periods during which a continuous monitoring system or monitoring device is inoperative.

Condition 51: Facility files for subject sources.
Effective between the dates of 08/01/2013 and 07/31/2018

Applicable Federal Requirement: 40CFR 60.7(f), NSPS Subpart A

Item 51.1:
The following files shall be maintained at the facility for all affected sources: all measurements, including continuous monitoring systems; monitoring device, and performance testing; measurements; all continuous monitoring system performance evaluations; all continuous monitoring device calibration checks, adjustments and maintenance performed on these systems or devices; and all other information required by this part, recorded in permanent form suitable for inspection. The file shall be maintained for at least two years following the date of such measurements, reports, and records.

Condition 52: Performance testing timeline.
Effective between the dates of 08/01/2013 and 07/31/2018

Applicable Federal Requirement: 40CFR 60.8(a), NSPS Subpart A

Item 52.1:
Within 60 days after achieving the maximum production rate, but not later than 180 days after initial startup of the facility, the owner or operator of the facility shall conduct performance testing and provide the results of such tests, in a written report, to the Administrator.

Condition 53: Performance test methods.
Effective between the dates of 08/01/2013 and 07/31/2018

Applicable Federal Requirement: 40CFR 60.8(b), NSPS Subpart A

Item 53.1:
Performance testing shall be conducted in accordance with the methods and procedures prescribed in 40 CFR 60 or by alternative methods and procedures approved by the Administrator.

Condition 54: Prior notice.
Effective between the dates of 08/01/2013 and 07/31/2018

Applicable Federal Requirement: 40CFR 60.8(c), NSPS Subpart A

Item 54.1:
The owner or operator shall provide the Administrator with prior notice of any performance test at least 30 days in advance of testing.

Condition 55: Performance testing facilities.
Effective between the dates of 08/01/2013 and 07/31/2018

Applicable Federal Requirement: 40CFR 60.8(e), NSPS Subpart A



Item 55.1:

The following performance testing facilities shall be provided during all tests:

- 1) sampling ports adequate for test methods applicable to each facility;
- 2) a safe sampling platform;
- 3) a safe access to the sampling platform; and
- 4) utilities for sampling and testing equipment.

Condition 56: Number of required tests.
Effective between the dates of 08/01/2013 and 07/31/2018

Applicable Federal Requirement: 40CFR 60.800, NSPS Subpart A

Item 56.1:

Each performance test shall consist of three separate runs, at the specified duration required in the applicable test method. Compliance with all applicable standards shall be determined by using the arithmetic means of the results of the three runs.

Condition 57: Applicability.
Effective between the dates of 08/01/2013 and 07/31/2018

Applicable Federal Requirement: 40CFR 60, NSPS Subpart III

Item 57.1:

This Condition applies to:

Emission Unit: U00004	
Process: P04	Emission Source: EG001
Emission Unit: U00005	
Process: P05	Emission Source: EP001

Item 57.2:

Facilities that have stationary compression ignition internal combustion engines must comply with applicable portions of 40CFR 60, Subpart III.

Condition 58: Compliance Demonstration.
Effective between the dates of 08/01/2013 and 07/31/2018

Applicable Federal Requirement: 40CFR 60.4335, NSPS Subpart KKKKc

Item 58.1:

The Compliance Demonstration activity will be performed for the facility:
The Compliance Demonstration applies to:

Emission Unit: U-00001 Emission Point: EP001



Emission Unit: U-00002

Emission Point: EP002

Regulated Contaminant(s):

CAS No: 0NT210-00-0 OXIDES OF NITROGEN

Item 58.2:

Compliance Demonstration shall include the following monitoring:

Monitoring Type: RECORD KEEPING/MAINTENANCE PROCEDURES

Monitoring Description:

As an alternative to continuously monitoring the water or steam to fuel ratio, the facility shall install, verify, maintain, and operate a continuous emission monitoring system (CEMS) consisting of a NOx monitor and a diluent gas (oxygen or carbon dioxide) monitor, to determine hourly NOx emissions in parts per million (ppm).

Reference Test Method: EPA Approved

Monitoring Frequency: CONTINUOUS

Reporting Requirements: SEMI-ANNUALLY (CALENDAR)

Reports due 30 days after the reporting period

The initial report is due 1/30/2014

Subsequent reports are due every 6 calendar month(s).

Condition 59: Compliance Demonstration

Effective between the dates of 08/01/2013 and 07/31/2018

Applicable Federal Requirement: 40CFR 60.4375(a), NSPS Subpart

KKKK

Item 59.1:

The Compliance Demonstration activity will be performed for the facility;

The Compliance Demonstration applies to:

Emission Unit U-00001

Emission Unit U-00002

Item 59.2:

Compliance Demonstration shall include the following monitoring:

Monitoring Type: RECORD KEEPING/MAINTENANCE PROCEDURES

Monitoring Description:

For each affected unit required to continuously monitor parameters of emissions, or to periodically determine the fuel sulfur content, reports of excess emissions and monitor downtime shall be submitted in accordance with 40 CFR 60.7(c). Excess emissions must be reported for all periods of unit operation, including start-up, shutdown, and malfunction.

Monitoring Frequency: AS REQUIRED - SEE PERMIT MONITORING



DESCRIPTION

Reporting Requirements: SEMI-ANNUALLY (CALENDAR)
Reports due 30 days after the reporting period.
The initial report is due 1/30/2014.
Subsequent reports are due every 6 calendar month(s).

Condition 60: Facility Subject to Title IV Acid Rain Regulations and Permitting
Effective between the dates of 08/01/2013 and 07/31/2018

Applicable Federal Requirement: 40 CFR Part 72

Item 60.1: This facility is subject to the Title IV Acid Rain Regulations found in 40 CFR Parts 72, 73, 75, 76, 77 and 78. The Acid Rain Permit is an attachment to this permit.

***** Emission Unit Level *****

Condition 61: Compliance Demonstration
Effective between the dates of 08/01/2013 and 07/31/2018

Applicable Federal Requirement: NYCRR 227-1.3 (a)

Item 61.1:
The Compliance Demonstration activity will be performed for the facility.
The Compliance Demonstration applies to:

Emission Unit: U-00001

Emission Unit: U-00002

Emission Unit: U-00003

Emission Unit: U-00004

Emission Unit: U-00005

Emission Unit: U-00006

Item 61.2:
Compliance Demonstration shall include the following monitoring:

Monitoring Type: MONITORING OF PROCESS OR CONTROL
DEVICE PARAMETERS AS SURROGATE

Monitoring Description:

No owner or operator of a combustion installation shall operate the installation in such a way to emit greater than 20 percent opacity except for one six minute period per hour, not to exceed 27 percent, based upon the six minute average in reference test Method 9 in Appendix A of 40 CFR 60.



Parameter Monitored: OPACITY
Upper Permit Limit: 20 percent
Reference Test Method: Method 9
Monitoring Frequency: AS REQUIRED - SEE PERMIT MONITORING

DESCRIPTION
Averaging Method: 6-MINUTE AVERAGE (METHOD 9)
Reporting Requirements: SEMI-ANNUALLY (CALENDAR)
Reports due 30 days after the reporting period
The initial report is due 1/30/2014
Subsequent reports are due every 6 calendar month(s)

Condition 62: Compliance Demonstration
Effective between the dates of 08/01/2013 and 07/31/2018

Applicable Federal Requirement: 6 NYCRR 227-1.3 (a)

Item 62.1:
The Compliance Demonstration activity will be performed for the facility:
The Compliance Demonstration applies to:

Emission Unit: U-00001	Emission Point: EP001
Process: P3A	Emission Source: CT001
Emission Unit: U-00002	Emission Point: EP002
Process: P03	Emission Source: CT001

Item 62.2:
Compliance Demonstration shall include the following monitoring:

Monitoring Type: MONITORING OF PROCESS OR CONTROL
DEVICE PARAMETERS AS SURROGATE

Monitoring Description:

No person shall operate a stationary combustion installation which exhibits greater than 20 percent opacity (60 minute average), except for one-six-minute period per hour of not more than 27 percent opacity. The Department reserves the right to perform or require the performance of a Method 9 opacity evaluation at any time during facility operation.

The permittee will conduct observations of visible emissions from the emission unit, process, etc. to which this condition applies at the monitoring frequency cited below while the process is in operation. The permittee will investigate, in a timely manner, any instance where there is cause to believe that visible emissions have the potential to exceed the opacity standard.

The permittee shall investigate the cause, make any necessary corrections, and verify that the excess visible emissions problem has been corrected. If visible emissions with the potential to exceed the standard



continue, the permittee will conduct a Method 9 assessment within the next operating day of the sources associated with the potential noncompliance to determine the degree of opacity and will notify the NYSDEC if the method 9 test indicates that the opacity standard is not met.

Records of visible emissions observations (or any follow-up method 9 tests), investigations and corrective actions will be kept on-site. Should the Department determine that permittee's record keeping format is inadequate to demonstrate compliance with this condition, it shall provide written notice to the permittee stating the inadequacies, and permittee shall have 90 days to revise its prospective record keeping format to a manner acceptable to the Department.

Parameter Monitored: OPACITY
Upper Permit Limit: 20 percent
Reference Test Method: EPA Method 9
Monitoring Frequency: When firing distillate fuel oil
Averaging Method: 6 MINUTE AVERAGE (METHOD 9)
Reporting Requirements: ANNUALLY (CALENDAR)
Reports due 50 days after the reporting period.
The initial report is due 1/30/2014.
Subsequent reports are due every 12 calendar month(s).

Condition 63: Compliance Demonstration
Effective between the dates of 08/01/2013 and 07/31/2018

Applicable Federal Requirement: 40CFR 60.43e(c), NSPS Subpart Dc

Item 63.1:
The Compliance Demonstration activity will be performed for:

Emission Unit: U-00003

Item 63.2:
Compliance Demonstration shall include the following monitoring:

Monitoring Type: INTERMITTENT EMISSION TESTING
Monitoring Description:

On and after the date on which the initial performance test is completed or required to be completed under §60.8, whichever date comes first, no owner or operator of an affected facility shall cause to be discharged into the atmosphere from that affected facility any gases that exhibit greater than 20 percent opacity (6-minute average), except for one 6-minute period per hour of not more than 27 percent opacity. The facility shall perform a method 9 evaluation.

Parameter Monitored: OPACITY



Upper Permit Limit: 20 percent
Reference Test Method: Method 9
Monitoring Frequency: SINGLE OCCURRENCE
Averaging Method: 6 MINUTE AVERAGE
Reporting Requirements: ONCE BATCH OR MONITORING OCCURRENCE

Condition 64: Compliance Demonstration
Effective between the dates of 08/01/2013 and 07/31/2018

Applicable Federal Requirement(s): 40 CFR 60.48e(a), NSPS Subpart Dc

Item 64.1:
The Compliance Demonstration activity will be performed for:

Emission Unit: U-00003

Item 64.2:
Compliance Demonstration shall include the following monitoring:

Monitoring Type: RECORD KEEPING/MAINTENANCE PROCEDURES
Monitoring Description:

- The owner and operator of each affected facility shall submit notification of the date of construction or reconstruction, anticipated startup, and actual startup, as provided by 40 CFR 60.7 of this part. This notification shall include:
- (1) The design heat input capacity of the affected facility and identification of fuels to be combusted in the affected facility.
 - (2) If applicable, a copy of any Federally enforceable requirement that limits the annual capacity factor for any fuel or mixture of fuels under 40 CFR 60.42c, or 40 CFR 60.43c.
 - (3) The annual capacity factor at which the owner or operator anticipates operating the affected facility based on all fuels fired and based on each individual fuel fired.

Monitoring Frequency: SINGLE OCCURRENCE
Reporting Requirements: AS REQUIRED -SEE MONITORING DESCRIPTION

Condition 65: Compliance Demonstration
Effective between the dates of 08/01/2013 and 07/31/2018

Applicable Federal Requirement(s): 6 NYCRR 231-5.4

Item 65.1:
The Compliance Demonstration activity will be performed for:

Emission Unit: U-00003
Process: P3B



Regulated Contaminant(s):

CAS No: 00Y998-00-0 VOC
CAS No: 00Y710-00-0 OXIDES OF NITROGEN

Item 65.2:

Compliance Demonstration shall include the following monitoring:

Monitoring Type: WORK PRACTICE INVOLVING SPECIFIC OPERATIONS

Monitoring Description:

Operation of the Auxiliary boiler is restricted to 2000 hours per year. Facility will maintain usage records and fuel consumption.

Work Practice Type: HOURS PER YEAR OPERATION

Upper Permit Limit: 2000 hours

Monitoring Frequency: DAILY

Averaging Method: 12-month total, rolled monthly

Reporting Requirements: ANNUALLY / CALENDAR

Reports due 30 days after the reporting period

The annual report is due 1/30/2014

Subsequent reports are due every 12 calendar month(s).

Condition 66: Compliance Demonstration

Effective between the dates of 08/01/2013 and 07/31/2018

Applicable Federal Requirement: 6 NYCRR 231-5.4

Item 66.1:

The Compliance Demonstration activity will be performed for:

Emission Unit: 000003

Process: P3B

Regulated Contaminant(s):

CAS No: 00Y998-00-0 VOC

Item 66.2:

Compliance Demonstration shall include the following monitoring:

Monitoring Type: INTERMITTENT EMISSION TESTING

Monitoring Description:

LAER is 0.0059 lb/mmBtu. Will be achieved using good combustion controls. Emission testing to be performed within 180 days of startup.

Upper Permit Limit: 0.0038 pounds per million Btus

Reference Test Method: Method 25A

Monitoring Frequency: SINGLE OCCURRENCE

Averaging Method: 1-HOUR AVERAGE

Reporting Requirements: ONCE / BATCH OR MONITORING OCCURRENCE



Condition 67: Compliance Demonstration
Effective between the dates of 08/01/2013 and 07/31/2018

Applicable Federal Requirement: 6 NYCRR 231-5.4

Item 67.1:
The Compliance Demonstration activity will be performed for:

Emission Unit: U-00003
Process: PAB

Regulated Contaminant(s)
CAS No: 007710-00-0 OXIDES OF NITROGEN

Item 67.2:
Compliance Demonstration shall include the following monitoring:

Monitoring Type: INTERMITTENT EMISSION TESTING
Monitoring Description:

LAER is 0.0450 lb/mmBtu. Will be achieved using low NOx burners and the gas re-circulation. Emission testing to be performed within 180 days of startup.

Upper Permit Limit: 0.045 pounds per million Btus
Reference Test Method: Method 7E
Monitoring Frequency: SINGLE OCCURRENCE
Averaging Method: 1 HOUR AVERAGE
Reporting Requirements: ONCE BATCH OR MONITORING OCCURRENCE

Condition 68: Compliance Demonstration
Effective between the dates of 08/01/2013 and 07/31/2018

Applicable Federal Requirement: 6 NYCRR 231-5.6

Item 68.1:
The Compliance Demonstration activity will be performed for:

Emission Unit: U-00003
Process: PAB

Regulated Contaminant(s)
CAS No: 007075-00-0 PARTICULATES
CAS No: 007075-00-5 TSP 10

Item 68.2:
Compliance Demonstration shall include the following monitoring:

Monitoring Type: INTERMITTENT EMISSION TESTING
Monitoring Description:

BACT is 0.0063 lb/mmBtu. Will be achieved using low sulfur fuel. Emission testing to be performed within 180



days of startup.

Upper Permit Limit: 0.0063 pounds per million Btus
Reference Test Method: Method 201/201A and 202
Monitoring Frequency: SINGLE OCCURRENCE
Averaging Method: 1-HOUR AVERAGE
Reporting Requirements: ONCE BATCH OR MONITORING OCCURRENCE

Condition 69: Compliance Demonstration
Effective between the dates of 08/01/2013 and 07/31/2018.

Applicable Federal Requirement: 6 NYCRR 231-7.6

Item 69.1:
The Compliance Demonstration activity will be performed for:

Emission Unit: U-00005
Process: P3B

Regulated Contaminant(s):
CAS No: 007446-09-5 SULFUR DIOXIDE

Item 69.2:
Compliance Demonstration shall include the following monitoring:

Monitoring Type: INTERMITTENT EMISSION TESTING
Monitoring Description:
BACT is 00022 lb/mmBtu. Will be achieved using low sulfur fuel. Emission testing to be performed within 180 days of startup.

Upper Permit Limit: 0.0022 pounds per million Btus
Reference Test Method: EPA approved methods
Monitoring Frequency: SINGLE OCCURRENCE
Averaging Method: 1-HOUR AVERAGE
Reporting Requirements: ONCE BATCH OR MONITORING OCCURRENCE

Condition 70: Compliance Demonstration
Effective between the dates of 08/01/2013 and 07/31/2018.

Applicable Federal Requirement: 6 NYCRR 231-7.6

Item 70.1:
The Compliance Demonstration activity will be performed for:

Emission Unit: U-00005
Process: P3B

Regulated Contaminant(s):
CAS No: 007664-93-9 SULFURIC ACID

Item 70.2:



Compliance Demonstration shall include the following monitoring:

Monitoring Type: INTERMITTENT EMISSION TESTING

Monitoring Description:

BACT is 0.0002 lb/mmBtu. Will be achieved using low sulfur fuel. Emission testing to be performed within 180 days of startup.

Upper Permit Limit: 0.0002 pounds per million Btu

Reference Test Method: EPA approved methods

Monitoring Frequency: SINGLE OCCURRENCE

Averaging Method: 1-HOUR AVERAGE

Reporting Requirements: ONCE / BATCH OR MONITORING OCCURRENCE

Condition 71: Compliance Demonstration
Effective between the dates of 08/01/2013 and 07/31/2018

Applicable Federal Requirements: NYCRR 231-7.6

Item 71.1:

The Compliance Demonstration activity will be performed for:

Emission Unit: U-00003

Process: P3B

Regulated Contaminant(s):

CaS No: 000630-08-0 CARBON MONOXIDE

Item 71.2:

Compliance Demonstration shall include the following monitoring:

Monitoring Type: INTERMITTENT EMISSION TESTING

Monitoring Description:

BACT is 0.0721 lb/mmBtu. Will be achieved using good combustion controls. Emission testing to be performed within 180 days of startup.

Upper Permit Limit: 0.0721 pounds per million Btu

Reference Test Method: Method 10

Monitoring Frequency: SINGLE OCCURRENCE

Averaging Method: 1-HOUR AVERAGE

Reporting Requirements: ONCE / BATCH OR MONITORING OCCURRENCE

Condition 72: Alternative recordkeeping
Effective between the dates of 08/01/2013 and 07/31/2018

Applicable Federal Requirement: 40CFR 60.48c(g)(2), NSPS Subpart Dc

Item 72.1:

This Condition applies to Emission Unit: U-00003

Process: P3B

Emission Source:

AUX01



Item 72.2: As an alternative to meeting the requirements of 40 CFR 60.48c(g)(1), the owner or operator of an affected facility that combusts only natural gas, wood, fuels using fuel certification in 40 CFR 60.48c(f) to demonstrate compliance with the SO₂ standard, fuels not subject to an emissions standard (excluding opacity), or a mixture of these fuels may elect to record and maintain records of the amount of each fuel combusted during each calendar month.

Condition 73: Compliance Demonstration
Effective between the dates of 08/01/2013 and 07/31/2018

Applicable Federal Requirement: 6 NYCRR 231-5.4

Item 73.1:
The Compliance Demonstration activity will be performed for:

Emission Unit: U-00004
Process: P04

Regulated Component(s):
CAS No: 08Y996-00-0 VOC

Item 73.2:
Compliance Demonstration shall include the following monitoring:

Monitoring Type: INTERMITTENT EMISSION TESTING
Monitoring Description:

LAER is 0.0331 lb/MMBtu. Will be achieved using good combustion controls. Emission testing to be performed upon request of the Department.

Upper Permit Limit: 0.0331 - pounds per million Btu
Reference Test Method: Method 25A
Monitoring Frequency: AS REQUIRED - SEE PERMIT MONITORING DESCRIPTION
Averaging Method: 1-HOUR AVERAGE
Reporting Requirements: ONCE / BATCH OR MONITORING OCCURRENCE

Condition 74: Compliance Demonstration
Effective between the dates of 08/01/2013 and 07/31/2018

Applicable Federal Requirement: 6 NYCRR 231-5.4

Item 74.1:
The Compliance Demonstration activity will be performed for:

Emission Unit: U-00004
Process: P04



Regulated Contaminant(s):
CAS No: 0000210-00-0 OXIDES OF NITROGEN

Item 74.2:
Compliance Demonstration shall include the following monitoring:

Monitoring Type: INTERMITTENT EMISSION TESTING
Monitoring Description:
LAER is 4.77 grams per brake horsepower-hour. Will be achieved using good combustion controls. Emission testing to be performed upon request of the Department.

Upper Permit Limit: 4.77 grams per brake horsepower-hour
Reference Test Method: Method 7E
Monitoring Frequency: AS REQUIRED - SEE PERMIT MONITORING DESCRIPTION
Averaging Method: 1-HOUR AVERAGE
Reporting Requirements: ONCE / BATCH OR MONITORING OCCURRENCE

Condition 75: Compliance Demonstration
Effective between the dates of 08/01/2013 and 07/31/2018

Applicable Federal Requirements: NYCRR 231-7.6

Item 75.1:
The Compliance Demonstration activity will be performed to:

Emission Unit: U00004
Process: P04

Regulated Contaminant(s):
CAS No: 0000075-00-0 PARTICULATES
CAS No: 0000075-00-5 PM-10

Item 75.2:
Compliance Demonstration shall include the following monitoring:

Monitoring Type: INTERMITTENT EMISSION TESTING
Monitoring Description:
BACT is 0.03 g/hp-hr. Will be achieved using low sulfur fuel. Emission testing to be performed at the request of the Department.

Upper Permit Limit: 0.03 grams per brake horsepower-hour
Reference Test Method: Method 201/201A and 202
Monitoring Frequency: AS REQUIRED - SEE PERMIT MONITORING DESCRIPTION
Averaging Method: 1-HOUR AVERAGE
Reporting Requirements: ONCE / BATCH OR MONITORING OCCURRENCE

Condition 76: Compliance Demonstration
Effective between the dates of 08/01/2013 and 07/31/2018



Applicable Federal Requirement: 6 NYCRR 231-7.6

Item 76.1:

The Compliance Demonstration activity will be performed for:

Emission Unit: U-00001
Process: P04

Regulated Contaminant(s):
CAS No: 007446095 SULFUR DIOXIDE

Item 76.2:

Compliance Demonstration shall include the following monitoring:

Monitoring Type: INTERMITTENT EMISSION TESTING

Monitoring Description:

BACT is 0.0014 lb/mmBtu. Will be achieved using low-sulfur fuel. Emission testing to be performed at the request of the Department.

Upper Permit Limit: 0.0014 pounds per million Btus

Reference Test Method: EPA approved methods

Monitoring Frequency: AS REQUIRED - SEE PERMIT MONITORING DESCRIPTION

Averaging Method: 1 HOUR AVERAGE

Reporting Requirements: ONCE / BATCH OR MONITORING OCCURRENCE

Condition 77: Compliance Demonstration
Effective between the dates of 08/01/2013 and 07/31/2018

Applicable Federal Requirement: 6 NYCRR 231-7.6

Item 77.1:

The Compliance Demonstration activity will be performed for:

Emission Unit: U-00004
Process: P04

Regulated Contaminant(s):
CAS No: 007664-93-9 SULFURIC ACID

Item 77.2:

Compliance Demonstration shall include the following monitoring:

Monitoring Type: INTERMITTENT EMISSION TESTING

Monitoring Description:

BACT is 0.0003 lb/mmBtu. Will be achieved using low sulfur fuel. Emission testing to be performed at the request of the Department.

Upper Permit Limit: 0.0003 pounds per million Btus



Reference Test Method: EPA approved method
Monitoring Frequency: AS REQUIRED - SEE PERMIT MONITORING DESCRIPTION
Averaging Method: 1-HOUR AVERAGE
Reporting Requirements: ONCE BATCH OR MONITORING OCCURRENCE

Condition 78: Compliance Demonstration
Effective between the dates of 08/01/2013 and 07/31/2018

Applicable Federal Requirement: NYCRR 231-7.6

Item 78.1:
The Compliance Demonstration activity will be performed for:

Emission Line: U-00004
Process: P04

Regulated Contaminant(s):
CAS No: 000630-06-0 CARBON MONOXIDE

Item 78.2:
Compliance Demonstration shall include the following monitoring:

Monitoring Type: INTERMITTENT EMISSION TESTING
Monitoring Description:
BACT is 0.45 g/hp-hr. Will be achieved using good combustion controls. Emission testing to be performed at the request of the Department.

Upper Permit Limit: 0.45 grams per brake horsepower-hour
Reference Test Method: Method 10
Monitoring Frequency: AS REQUIRED - SEE PERMIT MONITORING DESCRIPTION
Averaging Method: 1-HOUR AVERAGE
Reporting Requirements: ONCE BATCH OR MONITORING OCCURRENCE

Condition 79: Compliance Demonstration
Effective between the dates of 08/01/2013 and 07/31/2018

Applicable Federal Requirement: NYCRR 231-5.4

Item 79.1:
The Compliance Demonstration activity will be performed for:

Emission Line: U-00005
Process: P05

Regulated Contaminant(s):
CAS No: 0NY210-00-0 OXIDES OF NITROGEN

Item 79.2:
Compliance Demonstration shall include the following monitoring:



Monitoring Type: INTERMITTENT EMISSION TESTING

Monitoring Description:

LAER is 0.657 pounds per million Btus. Will be achieved using good combustion controls. Emission testing to be performed upon request of the Department.

Upper Permit Limit: 0.857 pounds per million Btus

Reference Test Method: Method 9E

Monitoring Frequency: AS REQUIRED - SEE PERMIT MONITORING DESCRIPTION

Averaging Method: 1-HOUR AVERAGE

Reporting Requirements: ONCE / BATCH OR MONITORING OCCURRENCE

Condition 80: Compliance Demonstration
Effective between the dates of 08/01/2013 and 07/31/2018

Applicable Federal Requirement: 6 NYCRR 231-5.4

Item 80.1:

The Compliance Demonstration activity will be performed for:

Emission Unit: 0-00005

Process: P05

Regulated Contaminant(s)

CaS No: 08Y998-00-0 VOC

Item 80.2:

Compliance Demonstration shall include the following monitoring:

Monitoring Type: INTERMITTENT EMISSION TESTING

Monitoring Description:

LAER is 0.3612 lb/mmBtu. Will be achieved using good combustion controls. Emission testing to be performed upon request of the Department.

Upper Permit Limit: 0.562 pounds per million Btus

Reference Test Method: Method 15A

Monitoring Frequency: AS REQUIRED - SEE PERMIT MONITORING DESCRIPTION

Averaging Method: 1-HOUR AVERAGE

Reporting Requirements: ONCE / BATCH OR MONITORING OCCURRENCE

Condition 81: Compliance Demonstration
Effective between the dates of 08/01/2013 and 07/31/2018

Applicable Federal Requirement: 6 NYCRR 231-7.6

Item 81.1:

The Compliance Demonstration activity will be performed for:



Emission Unit: U-00005
Process: P05

Regulated Contaminant(s):
CAS No: 000630-00-0 CARBON MONOXIDE

Item 81.2:
Compliance Demonstration shall include the following monitoring:

Monitoring Type: INTERMITTENT EMISSION TESTING
Monitoring Description:
BACT is 0.75 lbs/mmBtu. Will be achieved using good combustion controls. Emission testing to be performed at the request of the Department.

Upper Permit Limit: 0.75 - pounds per million Btu
Reference Test Method: Method 10
Monitoring Frequency: AS REQUIRED - SEE PERMIT MONITORING DESCRIPTION
Averaging Method: 1-HOUR AVERAGE
Reporting Requirements: ONCE / BATCH OR MONITORING OCCURRENCE

Condition 82: Compliance Demonstration
Effective between the dates of 08/01/2013 and 07/31/2018.
Applicable Federal Requirement: 6 NYCRR 231-7.6

Item 82.1:
The Compliance Demonstration activity will be performed for:

Emission Unit: U-00005
Process: P05

Regulated Contaminant(s):
CAS No: 000075-00-0 PARTICULATES
CAS No: 000075-00-5 PM-10

Item 82.2:
Compliance Demonstration shall include the following monitoring:

Monitoring Type: INTERMITTENT EMISSION TESTING
Monitoring Description:
BACT is 0.043 lb/mmBtu. Will be achieved using low sulfur fuel. Emission testing to be performed at the request of the Department.

Upper Permit Limit: 0.043 - pounds per million Btu
Reference Test Method: Method 201/201A and 202
Monitoring Frequency: AS REQUIRED - SEE PERMIT MONITORING DESCRIPTION
Averaging Method: 1-HOUR AVERAGE
Reporting Requirements: ONCE / BATCH OR MONITORING OCCURRENCE



Condition 83: Compliance Demonstration
Effective between the dates of 08/01/2013 and 07/31/2018

Applicable Federal Requirement: 6 NYCRR 231-7.6

Item 83.1:
The Compliance Demonstration activity will be performed for:

Emission Unit: U-00005
Process: P05

Regulated Contaminant(s)
CAS No: 0007046-09-5 SULFUR DIOXIDE

Item 83.2:
Compliance Demonstration shall include the following monitoring:

Monitoring Type: INTERMITTENT EMISSION TESTING
Monitoring Description:

BACT is 0.0014 lb/mmBtu. Will be achieved using low sulfur fuel. Emission testing to be performed at the request of the Department.

Upper Permit Limit: 0.0014 pounds per million Btus
Reference Test Method: EPA approved methods
Monitoring Frequency: AS REQUIRED - SEE PERMIT MONITORING DESCRIPTION
Averaging Method: 1-HOUR AVERAGE
Reporting Requirement: ONCE / BATCH OR MONITORING OCCURRENCE

Condition 84: Compliance Demonstration
Effective between the dates of 08/01/2013 and 07/31/2018

Applicable Federal Requirement: 6 NYCRR 231-7.6

Item 84.1:
The Compliance Demonstration activity will be performed for:

Emission Unit: U-00005
Process: P05

Regulated Contaminant(s)
CAS No: 00000493-9 SULFURIC ACID

Item 84.2:
Compliance Demonstration shall include the following monitoring:

Monitoring Type: INTERMITTENT EMISSION TESTING
Monitoring Description:

BACT is 0.00003 lb/mmBtu. Will be achieved using low sulfur fuel. Emission testing to be performed at the



request of the Department.

Upper Permit Limit: 0.0005 pounds per million Btus
Reference Test Method: EPA approved methods
Monitoring Frequency: AS REQUIRED - SEE PERMIT MONITORING DESCRIPTION
Averaging Method: 1-HOUR AVERAGE
Reporting Requirements: ONCE / BATCH OR MONITORING OCCURRENCE

Condition 85: Compliance Demonstration
Effective between the dates of 08/01/2013 and 07/31/2018

Applicable Federal Requirements: NYCRR 231-5.4

Item 85.1:
The Compliance Demonstration activity will be performed for:

Emission Unit: U-00006
Process: P06

Regulated Contaminant(s):
CAS No. 0N1231600-0 OXIDES OF NITROGEN

Item 85.2:
Compliance Demonstration shall include the following monitoring:

Monitoring Type: INTERMITTENT EMISSION TESTING
Monitoring Description:
LAER is 0.058 pounds per million Btus for each individual gas heater. Will be achieved using forced draft low NOx burner. Emission testing to be performed upon request of the Department.

Upper Permit Limit: 0.058 pounds per million Btus
Reference Test Method: Method 7E
Monitoring Frequency: AS REQUIRED - SEE PERMIT MONITORING DESCRIPTION
Averaging Method: 1-HOUR AVERAGE
Reporting Requirements: ONCE / BATCH OR MONITORING OCCURRENCE

Condition 86: Compliance Demonstration
Effective between the dates of 08/01/2013 and 07/31/2018

Applicable Federal Requirements: NYCRR 231-5.4

Item 86.1:
The Compliance Demonstration activity will be performed for:

Emission Unit: U-00006
Process: P06

Regulated Contaminant(s):



CAS No: 00Y998-00-0 VDC

Item 86.2:

Compliance Demonstration shall include the following monitoring:

Monitoring Type: INTERMITTENT EMISSION TESTING

Monitoring Description:

EAER is 0.011 lb/mmBtu. Will be achieved using good combustion controls. Emission testing to be performed upon request of the Department.

Upper Permit Limit: 0.011 pounds per million Btus

Reference Test Method: Method 25A

Monitoring Frequency: AS REQUIRED - SEE PERMIT MONITORING DESCRIPTION

Averaging Method: 1-HOUR AVERAGE

Reporting Requirements: ONCE / BATCH OR MONITORING OCCURRENCE

Condition 87: Compliance Demonstration

Effective between the dates of 08/01/2013 and 07/31/2018

Applicable Federal Requirement: 6 NYCRR 231-7.6

Item 87.1:

The Compliance Demonstration activity will be performed for:

Emission Unit: U-00006

Process: P06

Regulated Contaminant(s):

CAS No: 007664-93-9 SULFURIC ACID

Item 87.2:

Compliance Demonstration shall include the following monitoring:

Monitoring Type: INTERMITTENT EMISSION TESTING

Monitoring Description:

BACT is 0.0002 lb/mmBtu. Will be achieved using low sulfur fuel. Emission testing to be performed at the request of the Department.

Upper Permit Limit: 0.0002 pounds per million Btus

Reference Test Method: EPA approved methods

Monitoring Frequency: AS REQUIRED - SEE PERMIT MONITORING DESCRIPTION

Averaging Method: 1-HOUR AVERAGE

Reporting Requirements: ONCE / BATCH OR MONITORING OCCURRENCE

Condition 88: Compliance Demonstration

Effective between the dates of 08/01/2013 and 07/31/2018

Applicable Federal Requirement: 6 NYCRR 231-7.6



Item 88.1:

The Compliance Demonstration activity will be performed for:

Emission Unit: U-00006

Process: P06

Regulated Contaminant(s)

CAS No. 000830-08-9 CARBON MONOXIDE

Item 88.2:

Compliance Demonstration shall include the following monitoring:

Monitoring Type: INTERMITTENT EMISSION TESTING

Monitoring Description:

BACT is 0.084 lb/mmBtus. Will be achieved using good combustion controls. Emission testing to be performed at the request of the Department.

Upper Permit Limit: 0.084 pounds per million Btus

Reference Test Method: Method 10

Monitoring Frequency: AS REQUIRED - SEE PERMIT MONITORING DESCRIPTION

Averaging Method: FLOW AVERAGE

Reporting Requirements: ONCE A BATCH OR MONITORING OCCURRENCE

Condition 89: Compliance Demonstration

Effective between the dates of 08/01/2013 and 07/31/2018

Applicable Federal Requirement: 6 NYCRR 231-7.6

Item 89.1:

The Compliance Demonstration activity will be performed for:

Emission Unit: U-00006

Process: P06

Regulated Contaminant(s)

CAS No. 000075-00-0 PARTICULATES

CAS No. 000075-00-5 PM-10

Item 89.2:

Compliance Demonstration shall include the following monitoring:

Monitoring Type: INTERMITTENT EMISSION TESTING

Monitoring Description:

BACT is 0.0076 lb/mmBtus. Will be achieved using low sulfur fuel. Emission testing to be performed at the request of the Department.

Upper Permit Limit: 0.0076 pounds per million Btus

Reference Test Method: Method 201/201A and 202



Monitoring Frequency: AS REQUIRED - SEE PERMIT MONITORING DESCRIPTION
Averaging Method: 1-HOUR AVERAGE
Reporting Requirements: ONCE / BATCH OR MONITORING OCCURRENCE

Condition 90: Compliance Demonstration
Effective between the dates of 08/01/2013 and 07/31/2018

Applicable Federal Requirement(s) 6 NYCRR 251-7.6

Item 90.1:
The Compliance Demonstration activity will be performed for:

Emission Unit: U-00000
Process: P06

Regulated Component(s):
CAS No: 007446-09-5 SULFUR DIOXIDE

Item 90.2:
Compliance Demonstration shall include the following monitoring:

Monitoring Type: INTERMITTENT EMISSION TESTING
Monitoring Description:
BACT is 0.0022 lb/mmBtu. Will be achieved using low sulfur fuel. Emission testing to be performed at the request of the Department.

Upper Permit Limit: 0.0022 pounds per million Btu
Reference Test Method: EPA approved method
Monitoring Frequency: AS REQUIRED - SEE PERMIT MONITORING DESCRIPTION
Averaging Method: 1-HOUR AVERAGE
Reporting Requirements: ONCE / BATCH OR MONITORING OCCURRENCE



STATE ONLY ENFORCEABLE CONDITIONS
NYCRR Facility Level

NOTIFICATION OF GENERAL PERMITTEE OBLIGATIONS

This section contains terms and conditions which are not federally enforceable. Permittees may also have other obligations under regulations of general applicability.

- Item A: Public Access to Recordkeeping for Facilities With State Facility Permits - 6 NYCRR 201-4.10 (a)**
Where facility owners and/or operators keep records pursuant to compliance with the requirements of 6 NYCRR Subpart 201-5.4 and/or the emission capting requirements of 6 NYCRR Subpart 201-7, the Department will make such records available to the public upon request in accordance with 6 NYCRR Part 610 - Public Access to Records. Facility owners and/or operators must submit the records required to comply with the request within sixty working days of written notification by the Department.
- Item B: General Provisions for State Enforceable Permit Terms and Condition - 6 NYCRR Part 201-5**
Any person who owns and/or operates stationary sources shall operate and maintain all emission units and any required emission control devices in compliance with all applicable Parts of this Chapter and existing laws, and shall operate the facility in accordance with all criteria, emission limits, terms, conditions, and standards in this permit. Failure of such person to properly operate and maintain the effectiveness of such emission units and emission control devices may be sufficient reason for the Department to revoke or deny a permit.

The owner or operator of the permitted facility must maintain all required records on-site for a period of five years and make them available to representatives of the Department upon request. Department representatives must be granted access to any facility regulated by this Subpart during normal operating hours, for the purpose of determining compliance with this and any other state and federal air pollution control requirements, regulations or law.

STATE ONLY APPLICABLE REQUIREMENTS

The following conditions are state only enforceable.

- Condition 91: Contaminant List**
Effective between the dates of 08/01/2013 and 07/31/2018



Applicable State Requirement: ECL 19-0304

Item 91.1:

Emissions of the following contaminants are subject to contaminant specific requirements in this permit (emission limits, control requirements or compliance monitoring condition).

CAS No: 000124-38-9
Name: CARBON DIOXIDE

CAS No: 000830-08-0
Name: CARBON MONOXIDE

CAS No: 007446-09-5
Name: SULFUR DIOXIDE

CAS No: 007664-41-7
Name: AMMONIA

CAS No: 007664-93-9
Name: SULFURIC ACID

CAS No: 000075-00-0
Name: PARTICULATES

CAS No: 000075-00-5
Name: PM 10

CAS No: 000075-00-5
Name: PM 2.5

CAS No: 000210-00-0
Name: OXIDES OF NITROGEN

CAS No: 000000-00-0
Name: VOC

Condition 92: Unavoidable noncompliance and violations
Effective between the dates of 08/01/2013 and 07/31/2018

Applicable State Requirement: 6 NYCRR 201-1.4

Item 92.1:

At the discretion of the commissioner a violation of any applicable emission standard for necessary scheduled equipment maintenance, start-up/shutdown conditions and malfunctions or upsets may be excused if such violations are unavoidable. The following actions and recordkeeping and reporting requirements must be adhered to in such circumstances.

- (a) The facility owner and/or operator shall compile and maintain records of all equipment maintenance or start-up/shutdown activities when they can be expected to result in an exceedance of any applicable emission standard, and shall submit a report of such activities to the commissioner's representative when requested to do so in writing or when so required by a



condition of a permit issued for the corresponding air contamination source except where conditions elsewhere in this permit which contain more stringent reporting and notification provisions for an applicable requirement, in which case they supersede those stated here. Such reports shall describe why the violation was unavoidable and shall include the time, frequency and duration of the maintenance and/or start-up/shutdown activities and the identification of air contaminants and the estimated emission rates. If a facility owner and/or operator is subject to continuous stack monitoring and quarterly reporting requirements, he need not submit reports for equipment maintenance or start-up/shutdown for the facility to the commissioner's representative.

(b) In the event that emissions of air contaminants in excess of any emission standard in 6 NYCRR Chapter III Subchapter A occur due to a malfunction, the facility owner and/or operator shall report such malfunction by telephone to the commissioner's representative as soon as possible during normal working hours, but in any event not later than two working days after becoming aware that the malfunction occurred. Within 30 days thereafter, when requested in writing by the commissioner's representative, the facility owner and/or operator shall submit a written report to the commissioner's representative describing the malfunction, the corrective action taken, identification of air contaminants, and an estimate of the emission rates. These reporting requirements are superseded by conditions elsewhere in this permit which contain reporting and notification provisions for applicable requirements more stringent than those above.

(c) The Department may also require the owner and/or operator to include in reports described under (a) and (b) above an estimate of the maximum ground level concentration of each air contaminant emitted and the effect of such emissions depending on the deviation of the malfunction and the air contaminants emitted.

(d) In the event of maintenance, start-up/shutdown or malfunction conditions which result in emissions exceeding any applicable emission standard, the facility owner and/or operator shall take appropriate action to prevent emissions which will result in nonattainment of any applicable ambient air quality standard. Reasonably available control technology, as determined by the commissioner, shall be applied during any maintenance, start-up/shutdown or malfunction condition subject to this paragraph.

(e) In order to have a violation of a federal regulation (such as a new source performance standard or national emissions standard for hazardous air pollutants) excused, the specific federal regulation must provide for an affirmative defense during start-up, shutdowns, malfunctions or upsets.

Condition 93: Emission Unit Definition
Effective between the dates of 08/01/2013 and 07/31/2018

Applicable State Requirement: 6 NYCRR Subpart 201-5

Item 93.1:

The facility is authorized to perform regulated processes under this permit for:

Emission Unit: U-00001

Emission Unit Description:

ONE F CLASS COMBUSTION TURBINE RATED AT
1998 MMBTU/HR AT 51 DEGREES F (2234
MMBTU/HR AT -5 DEGREES F) ON NATURAL GAS
AND 2145 MMBTU/HR AT -5 DEGREES F ON FUEL



OIL (0.0005% SULFUR). THE TURBINE IS EQUIPPED WITH DRY LOW-NOX COMBUSTORS, STEAM INJECTION, SCR AND OXIDATION CATALYST EMISSION CONTROLS. THIS EMISSION UNIT ALSO CONTAINS A NATURAL GAS-FIRED DUCT BURNER RATED AT A MAXIMUM CAPACITY OF 500 MMBTU/HR.

Building(s): ACC01
GEN01
HRSG01

Item 93.2:

The facility is authorized to perform regulated processes under this permit for:

Emission Unit: U-00002

Emission Unit Description:

ONE CLASS-F COMBUSTION TURBINE RATED AT 1998 MMBTU/HR AT 51 DEGREES F (2254 MMBTU/HR AT -5 DEGREES F) ON NATURAL GAS AND 2145 MMBTU/HR AT -5 DEGREES F ON FUEL OIL (0.0005% SULFUR). THE TURBINE IS EQUIPPED WITH DRY LOW-NOX COMBUSTORS, STEAM INJECTION, SCR AND OXIDATION CATALYST EMISSION CONTROLS. THIS EMISSION UNIT ALSO CONTAINS A NATURAL GAS-FIRED DUCT BURNER RATED AT A MAXIMUM CAPACITY OF 500 MMBTU/HR.

Building(s): ACC02
GEN02
HRSG02

Item 93.3:

The facility is authorized to perform regulated processes under this permit for:

Emission Unit: U-00003

Emission Unit Description:

ONE 15.5 MMBTU/HR AUXILIARY BOILER THAT WILL FIRE NATURAL GAS EXCLUSIVELY. THE BOILER HOURS WILL BE LIMITED TO 2000 HOURS PER YEAR. THE BOILER WILL OPERATE PRIMARILY TO ASSIST WITH STARTUPS AND SHUTDOWNS OF THE TURBINES.

Building(s): GEN01

Item 93.4:

The facility is authorized to perform regulated processes under this permit for:

Emission Unit: U-00004

Emission Unit Description:

Emergency Diesel Generator operating less than 500 hours per year.



Item 93.5:

The facility is authorized to perform regulated processes under this permit for:

Emission Unit U-00005

Emission Unit Description:

Emergency Fire water Pump

Item 93.6:

The facility is authorized to perform regulated processes under this permit for:

Emission Unit U-00005

Emission Unit Description:

Two Fuel Gas Heaters

Condition 94: Visible Emissions Limited

Effective between the dates of 08/01/2013 and 07/31/2018

Applicable State Requirement: 6 NYCRR 211.2

Item 94.1:

Except as permitted by a specific part of this Subchapter and for open fires for which a restricted burning permit has been issued, no person shall cause or allow any air contamination source to emit any material having an opacity equal to or greater than 20 percent (six minute average) except for one continuous six-minute period per hour of not more than 57 percent opacity.

Condition 95: CO2 Budget Trading Program - Excess emission requirements

Effective between the dates of 08/01/2013 and 07/31/2018

Applicable State Requirement: 6 NYCRR 242-1.5

Item 95.1:

The owners and operators of a CO2 budget source that has excess emissions in any control period shall:

- (1) forfeit the CO2 allowances required for deduction under 6 NYCRR Part 242-6.5(d)(1), provided CO2 offset allowances may not be used to cover any part of such excess emissions; and
- (2) pay any fine, penalty, or assessment or comply with any other remedy imposed under 6 NYCRR Part 242-6.5(d)(2).

Condition 96: Compliance Demonstration

Effective between the dates of 08/01/2013 and 07/31/2018

Applicable State Requirement: 6 NYCRR 242-1.5

Item 96.1:

The Compliance Demonstration activity will be performed for the facility.

Item 96.2:

Compliance Demonstration shall include the following monitoring:

Monitoring Type: RECORD KEEPING/MAINTENANCE PROCEDURES

Monitoring Description:

The owners and operators and, to the extent applicable, the CO2 authorized account representative of each CO2 budget source and each CO2 budget unit at the source shall



comply with the monitoring requirements of Subpart 242-6.
The emissions measurements recorded and reported in accordance with Subpart 242-8 of this Part shall be used to determine compliance by the unit with the following CO₂ requirements:

(1) The owners and operators of each CO₂ budget source and each CO₂ budget unit at the source shall hold CO₂ allowances available for compliance deductions under Section 242-6.5, as of the CO₂ allowance transfer deadline, in the source's compliance account in an amount not less than the total CO₂ emissions for the control period from all CO₂ budget units at the source, as determined in accordance with Subparts 242-6 and 242-8.

(2) Each ton of CO₂ emitted in excess of the CO₂ budget emissions limitation shall constitute a separate violation of this Part and applicable state law.

(3) A CO₂ budget unit shall be subject to the requirements specified in item 1 starting on the later, of January 1, 2009 or the date on which the unit commences operation.

(4) CO₂ allowances shall be held in, deducted from, or transferred among CO₂ Allowance Trading System accounts in accordance with Subparts 242-5, 242-6, and 242-7, and Section 242-10.7.

(5) A CO₂ allowance shall not be deducted, in order to comply with the requirements specified in item 1, for a control period that ends prior to the allocation year for which the CO₂ allowance was allocated. A CO₂ offset allowance shall not be deducted, in order to comply with the requirements under item 1, beyond the applicable percent limitations set out in 6NYCRR Part 242-6.5(a)(3).

(6) A CO₂ allowance under the CO₂ Budget Trading Program is a limited authorization by the Department or a participating state to emit one ton of CO₂ in accordance with the CO₂ Budget Trading Program. No provision of the CO₂ Budget Trading Program, the CO₂ budget permit application, or the CO₂ budget permit or any provision of law shall be construed to limit the authority of the Department or a participating state to terminate or limit such authorization.

(7) A CO₂ allowance under the CO₂ Budget Trading Program does not constitute a property right.



Monitoring Frequency: AS REQUIRED – SEE PERMIT MONITORING DESCRIPTION

Reporting Requirements: SEMI-ANNUALLY (CALENDAR)

Reports due 30 days after the reporting period.

The initial report is due 1/30/2014.

Subsequent reports are due every 6 calendar month(s).

Condition 97: **Compliance Demonstration**
Effective between the dates of 08/01/2013 and 07/31/2018

Applicable State Requirement: 6 NYCRR 242-1.5

Item 97.1:

The Compliance Demonstration activity will be performed for the Facility.

Item 97.2:

Compliance Demonstration shall include the following monitoring:

Monitoring Type: RECORD KEEPING/MAINTENANCE PROCEDURES

Monitoring Description:

The owners and operators of the CO₂ budget source and each CO₂ budget unit at the source shall keep on site at the source each of the following documents for a period of 10 years from the date the document is created. This period may be extended for cause, at any time prior to the end of 10 years, in writing by the department:

(i) The account certificate of representation for the CO₂ authorized account representative for the source and each CO₂ budget unit at the source and all documents that demonstrate the truth of the statements in the account certificate of representation, in accordance with 6 NYCRR Part 242-2.4 provided that the certificate and documents shall be retained on site of the source beyond said 10-year period until such documents are superseded because of the submission of a new account certificate of representation.

(ii) All emissions monitoring information, in accordance with Subpart 242-8 and 10 CFR 75.57.

(iii) Copies of all reports, compliance certifications, and other submissions and all records made or required under the CO₂ Budget Trading Program.

(iv) Copies of all documents used to complete a CO₂ budget permit application and any other submission under the CO₂ Budget Trading Program or to demonstrate compliance with the requirements of the CO₂ Budget Trading Program.

The CO₂ authorized account representative of a CO₂ budget source and each CO₂ budget unit at the source shall submit



(the reports and compliance certifications required under
the CO₂ Budget Trading Program, including those under
Subpart 242-4)

Monitoring Frequency: AS REQUIRED - SEE PERMIT MONITORING
DESCRIPTION

Reporting Requirements: SEMI-ANNUALLY (CALENDAR)
Reports due 30 days after the reporting period
The initial report is due 1/30/2014
Subsequent reports are due every 6 calendar month(s)

--- Emission Unit Level ---

Condition 98: Emission Point Definition By Emission Unit
Effective between the dates of 06/01/2013 and 07/31/2018

Applicable State Requirements: NYCRR Subpart 201-S

Item 98.1:

The following emission points are included in this permit for the cited Emission Unit:

Emission Unit: U-00001

Emission Point: EP001

Height (ft): 275

Diameter (in): 338

NY TMM (km): 4584.693

NY TME (km): 546.991

Item 98.2:

The following emission points are included in this permit for the cited Emission Unit:

Emission Unit: U-00002

Emission Point: EP002

Height (ft): 275

Diameter (in): 338

NY TMM (km): 4584.655

NY TME (km): 546.991

Item 98.3:

The following emission points are included in this permit for the cited Emission Unit:

Emission Unit: U-00003

Emission Point: EP003

Height (ft): 275

Diameter (in): 338

NY TMM (km): 4584.655

NY TME (km): 546.991

Item 98.4:

The following emission points are included in this permit for the cited Emission Unit:

Emission Unit: U-00004



Emission Point: EP004
Height (ft): 50 Diameter (in): 18
NYTAMN (km): 4571.651 NYTME (km): 5471.29

Item 98.5:

The following emission points are included in this permit for the cited Emission Unit:

Emission Unit: U-00005

Emission Point: EP005
Height (ft): 50 Diameter (in): 6
NYTAMN (km): 4584.669 NYTME (km): 5468.15

Item 98.6:

The following emission points are included in this permit for the cited Emission Unit:

Emission Unit: U-00006

Emission Point: EP006
Height (ft): 125 Diameter (in): 24
NYTAMN (km): 4584.58 NYTME (km): 5469.96

Condition 99: Process Definition By Emission Point
Effective between the dates of 08/01/2013 and 07/31/2018.

Applicable State Requirement: 6 NYCRR Subpart 201-5

Item 99.1:

This permit authorizes the following regulated processes for the cited Emission Unit:

Emission Unit: U-00001
Process: PLA Source Classification Code: 2-01-002-01
Process Description:

REPRESENTS NATURAL GAS FIRING IN THE CLASS-F COMBUSTION TURBINE WHICH IS RATED AT 2,234 MMBtu/hr AT -5 DEGREES F (MAXIMUM HEAT INPUT SCENARIO). DRY LOW-NOX COMBUSTION TECHNOLOGY, SELECTIVE CATALYTIC REDUCTION (SCR) AND OXIDATION CATALYST WILL BE USED TO MINIMIZE EMISSIONS OF NOX, CO, AND VOC. THE QUANTITY PER HOUR THROUGHPUT LISTED BELOW REPRESENTS THE MAXIMUM FIRING RATE (2,234 MMBtu/hr AT -5 DEGREES F) AND THE QUANTITY PER YEAR THROUGHPUT REPRESENTS THE TURBINE AT THE FIRING RATE AT THE ANNUAL AVERAGE AMBIENT TEMPERATURE (OF 51 DEGREES F) (1,998 MMBtu/hr). NATURAL GAS HIGHER HEATING VALUE IS ASSUMED TO BE 1,048 BTU/CUBIC FOOT.

Emission Source/Control: CT001 - Combustion
Design Capacity: 2,234 million Btu per hour



Emission Source/Control: DLN01 - Control
Control Type: DRY LOW NOx BURNER

Emission Source/Control: OXY01 - Control
Control Type: CATALYTIC OXIDATION

Emission Source/Control: SCR01 - Control
Control Type: SELECTIVE CATALYTIC REDUCTION (SCR)

Item 99.2:

This permit authorizes the following regulated processes for the cited Emission Unit:

Emission Unit: U-00900

Process: P2A

Source Classification Code: 2-01-002-01

Process Description:

REPRESENTS COMBINED NATURAL GAS FIRING IN THE CLASS-F COMBUSTION TURBINE, WHICH IS RATED AT 2,234 mmBTU/hr AT -5 DEGREES F (MAXIMUM HEAT INPUT SCENARIO) AND NATURAL GAS FIRING IN THE DUCT BURNER, WHICH IS RATED AT 500 mmBTU/hr. DRY LOW-NOx COMBUSTION TECHNOLOGY, SELECTIVE CATALYTIC REDUCTION (SCR) AND OXIDATION CATALYST WILL BE USED TO MINIMIZE EMISSIONS OF NOx, CO, AND VOC. THE QUANTITY PER HOUR THROUGHPUT LISTED BELOW REPRESENTS THE MAXIMUM FIRING RATE (2,234 MMBtu/hr AT -5 DEGREES F) OF THE TURBINE PLUS THE DUCT BURNER AT RATED CAPACITY (500 mmBTU/hr) AND THE QUANTITY PER YEAR THROUGHPUT REPRESENTS 8,760 HOURS OF NATURAL GAS FIRING IN THE TURBINE AT THE ANNUAL AVERAGE AMBIENT TEMPERATURE OF 51 DEGREES F (1,998 MMBtu/hr). NATURAL GAS LUCHER HEATING VALUE IS ASSUMED TO BE 1,048 BTU/CUBIC FOOT.

Emission Source/Control: CT001 - Combustion
Design Capacity: 2,254 million Btu per hour

Emission Source/Control: DB001 - Combustion
Design Capacity: 500 million Btu per hour

Emission Source/Control: DLN01 - Control
Control Type: DRY LOW NOx BURNER

Emission Source/Control: OXY01 - Control
Control Type: CATALYTIC OXIDATION

Emission Source/Control: SCR01 - Control
Control Type: SELECTIVE CATALYTIC REDUCTION (SCR)



Item 99.3:

This permit authorizes the following regulated processes for the cited Emission Unit:

Emission Unit: U-00001

Process: P3A

Source Classification Code: 2-01-001-01

Process Description:

REPRESENTS FUEL OIL FIRING IN THE CLASS-F COMBUSTION TURBINE, WHICH IS RATED AT 2,145 mmBTU/hr AT -5 DEGREES F (MAXIMUM HEAT INPUT SCENARIO). DRY LOW-NOX COMBUSTION TECHNOLOGY, STEAM OR WATER INJECTION, SELECTIVE CATALYTIC REDUCTION (SCR) AND OXIDATION CATALYST WILL BE USED TO MINIMIZE EMISSIONS OF NOX, CO, AND VOC. THE QUANTITY PER HOUR THROUGHPUT LISTED BELOW REPRESENTS THE MAXIMUM FIRING RATE (2,145 MMBtu/hr AT -5 DEGREES F) AND THE QUANTITY PER YEAR THROUGHPUT REPRESENTS 720 HOURS OF FUEL OIL FIRING AT THE FIRING RATE AT -5 DEGREES F AMBIENT TEMPERATURE. FUEL OIL FRIEGER HEATING VALUE IS ASSUMED TO BE 139,728 BTU/GALLON.

Emission Source/Control: C1001 - Combustion
Design Capacity: 2,254 million Btu per hour

Emission Source/Control: DLN01 - Control
Control Type: DRY LOW NOX BURNER

Emission Source/Control: OX001 - Control
Control Type: CATALYTIC OXIDATION

Emission Source/Control: SCR01 - Control
Control Type: SELECTIVE CATALYTIC REDUCTION (SCR)

Emission Source/Control: ST101 - Control
Control Type: STEAM OR WATER INJECTION

Item 99.3:

This permit authorizes the following regulated processes for the cited Emission Unit:

Emission Unit: U-00002

Process: B01

Source Classification Code: 2-01-002-01

Process Description:

REPRESENTS NATURAL GAS FIRING IN THE CLASS-F COMBUSTION TURBINE, WHICH IS RATED AT 2,254 mmBTU/hr AT -5 DEGREES F (MAXIMUM HEAT INPUT SCENARIO). DRY LOW-NOX COMBUSTION TECHNOLOGY, SELECTIVE CATALYTIC REDUCTION (SCR) AND OXIDATION CATALYST WILL BE USED TO MINIMIZE EMISSIONS OF NOX, CO, AND VOC. THE QUANTITY PER HOUR THROUGHPUT



LISTED BELOW REPRESENTS THE MAXIMUM FIRING RATE (2,234 MMBtu/hr AT -5 DEGREES F) AND THE QUANTITY PER YEAR THROUGHPUT REPRESENTS THE TURBINE AT THE FIRING RATE AT THE ANNUAL AVERAGE AMBIENT TEMPERATURE OF 51 DEGREES F (1,998 MMBtu/hr). NATURAL GAS HEATER HEATING VALUE IS ASSUMED TO BE 1,048 BTU/CUBIC FOOT.

Emission Source/Control: CT002 - Combustion
Design Capacity: 2,234 million Btu per hour

Emission Source/Control: DLN02 - Control
Control Type: DRY LOW NOX BURNER

Emission Source/Control: OXYD2 - Control
Control Type: CATALYTIC OXIDATION

Emission Source/Control: SCR03 - Control
Control Type: SELECTIVE CATALYTIC REDUCTION (SCR)

Item 99.5:

This permit modifies the following regulated processes for the cited Emission Unit:

Emission Unit: U-00002

Process: P02

Source Classification Code: 99-002-01

Process Description:

REPRESENTS COMBINED NATURAL GAS FIRING IN THE CLASS-F COMBUSTION TURBINE WHICH IS RATED AT 2,234 mmBTU/hr AT -5 DEGREES F (MAXIMUM HEAT INPUT SCENARIO) AND NATURAL GAS FIRING IN THE DUCT BURNER, WHICH IS RATED AT 500 mmBTU/hr. DRY LOW-NOX COMBUSTION TECHNOLOGY, SELECTIVE CATALYTIC REDUCTION (SCR) AND OXIDATION CATALYST WILL BE USED TO MINIMIZE EMISSIONS OF NOX, CO, AND VOC. THE QUANTITY PER HOUR THROUGHPUT LISTED BELOW REPRESENTS THE MAXIMUM FIRING RATE (2,234 MMBtu/hr AT -5 DEGREES F) OF THE TURBINE PLUS THE DUCT BURNER AT RATED CAPACITY (500 mmBTU/hr) AND THE QUANTITY PER YEAR THROUGHPUT REPRESENTS 8,760 HOURS OF NATURAL GAS FIRING IN THE TURBINE AT THE ANNUAL AVERAGE AMBIENT TEMPERATURE OF 51 DEGREES F (1,998 MMBtu/hr). NATURAL GAS HEATER HEATING VALUE IS ASSUMED TO BE 1,048 BTU/CUBIC FOOT.

Emission Source/Control: CT002 - Combustion
Design Capacity: 2,234 million Btu per hour

Emission Source/Control: DB002 - Combustion



Design Capacity: 500 million Btu per hour

Emission Source/Control: DLN01 - Control
Control Type: DRY LOW NOX BURNER

Emission Source/Control: OXY02 - Control
Control Type: CATALYTIC OXIDATION

Emission Source/Control: SCR07 - Control
Control Type: SELECTIVE CATALYTIC REDUCTION (SCR)

Item 99.6:

This permit authorizes the following regulated processes for the cited Emission Unit:

Emission Unit: U-00002

Process: P03

Source Classification Code: 2-01-001-01

Process Description:

REPRESENTS FUEL OIL FIRING IN THE CLASS-F COMBUSTION TURBINE, WHICH IS RATED AT 2.145 MMBTU/hr AT -5 DEGREES F (MAXIMUM HEAT INPUT SCENARIO). DRY LOW-NOX COMBUSTION TECHNOLOGY, STEAM OR WATER INJECTION, SELECTIVE CATALYTIC REDUCTION (SCR) AND OXIDATION CATALYST WILL BE USED TO MINIMIZE EMISSIONS OF NOX, CO, AND VOC. THE QUANTITY PER HOUR THROUGHPUT LISTED BELOW REPRESENTS THE MAXIMUM FIRING RATE (2.145 MMBtu/hr AT -5 DEGREES F) AND THE QUANTITY PER YEAR THROUGHPUT REPRESENTS 720 HOURS OF FUEL OIL FIRING AT THE FIRING RATE AT -5 DEGREES F AMBIENT TEMPERATURE. FUEL OIL HEATING VALUE IS ASSUMED TO BE 139,778 BTU/GALLON

Emission Source/Control: CT002 - Combustion
Design Capacity: 2,254 million Btu per hour

Emission Source/Control: DLN02 - Control
Control Type: DRY LOW NOX BURNER

Emission Source/Control: OXY02 - Control
Control Type: CATALYTIC OXIDATION

Emission Source/Control: SCR03 - Control
Control Type: SELECTIVE CATALYTIC REDUCTION (SCR)

Emission Source/Control: ST102 - Control
Control Type: STEAM OR WATER INJECTION

Item 99.7:

This permit authorizes the following regulated processes for the cited Emission Unit:



Emission Unit: U-00003

Process: P3B

Source Classification Code: L-03-006-02

Process Description:

REPRESENTS NATURAL GAS FIRING IN THE
AUXILIARY BOILER WHICH IS RATED AT 73.5
MMBTU/HR. TOTAL NATURAL GAS USAGE WILL NOT
EXCEED 2,000 FULL LOAD BOILER HOURS PER
YEAR. NATURAL GAS HEATING VALUE IS
ASSUMED TO BE 1,048 BTU/CUBIC FOOT

Emission Source/Control: AUC01 - Combustion
Design Capacity: 73.5 million Btu per hour

Emission Source/Control: FCB01 - Control
Control Type: FLUE GAS RECIRCULATION

Emission Source/Control: LNB01 - Control
Control Type: LOW NOx BURNER

Item 99.8:

This permit authorizes the following regulated processes for the cited Emission Unit:

Emission Unit: U-00004

Process: P01

Process Description: Emergency generator firing diesel fuel

Emission Source/Control: EG001 - Combustion
Design Capacity: 15.43 million BTUs per hour

Item 99.9:

This permit authorizes the following regulated processes for the cited Emission Unit:

Emission Unit: U-00005

Process: P05

Process Description: Fire pump firing diesel fuel

Emission Source/Control: FP001 - Combustion
Design Capacity: 2.27 million Btu per hour

Item 99.10:

This permit authorizes the following regulated processes for the cited Emission Unit:

Emission Unit: U-00006

Process: P06

Process Description: gas heater operating on natural gas

Emission Source/Control: FGH01 - Combustion
Design Capacity: 5.02 million Btu per hour

Emission Source/Control: FHG02 - Combustion
Design Capacity: 5.02 million Btu per hour



Condition 100: Compliance Demonstration
Effective between the dates of 06/01/2013 and 07/31/2018

Applicable State Requirement: NYCRR 251.3 (a)

Item 100.1:

The Compliance Demonstration activity will be performed for the facility:
The Compliance Demonstration applies to:

Emission Unit: U-00001	Emission Point: EP001
Emission Unit: U-00002	Emission Point: EP002
Regulated Pollutant(s): CAS No: 000124-38-9	CARBON DIOXIDE

Item 100.2:

Compliance Demonstration shall include the following monitoring:

Monitoring Type: CONTINUOUS EMISSION MONITORING (CEM)

Monitoring Description:

Owners or operators of boilers that are permitted to fire greater than 70 percent fossil fuel, combined cycle combustion turbines, or stationary internal combustion engines that fire only gaseous fuel, except for those emission sources directly attached to a gasifier, are required to meet an emission rate of 925 pounds of CO₂ per MW from gross electrical output (output-based limit). These emission limits are measured on a 12-month rolling average basis, calculated by dividing the annual total of CO₂ emissions over the relevant 12-month period by the annual total (gross) MW generated (output-based limit). The owner or operator must maintain all records associated with these requirements on site or at a location acceptable to the Department for a minimum of five years.

Manufacturer/Name/Model Number: CO₂ Continuous Monitor

Parameter Monitored: CARBON DIOXIDE

Upper Permit Limit: 925 pounds per megawatt hour

Monitoring Frequency: CONTINUOUS

Averaging Method: 12-MONTH AVERAGE - ROLLED MONTHLY

Reporting Requirements: QUARTERLY (CALENDAR)

Reports due 30 days after the reporting period.

The initial report is due 10/30/2013.

Subsequent reports are due every 3 calendar month(s).





CPV Valley Energy Center
50 Braintree Hill Office Park
Suite 300
Braintree, MA 02184

ATTACHMENT 5

Plot Plan,
Facility General Arrangement,
Process Diagram

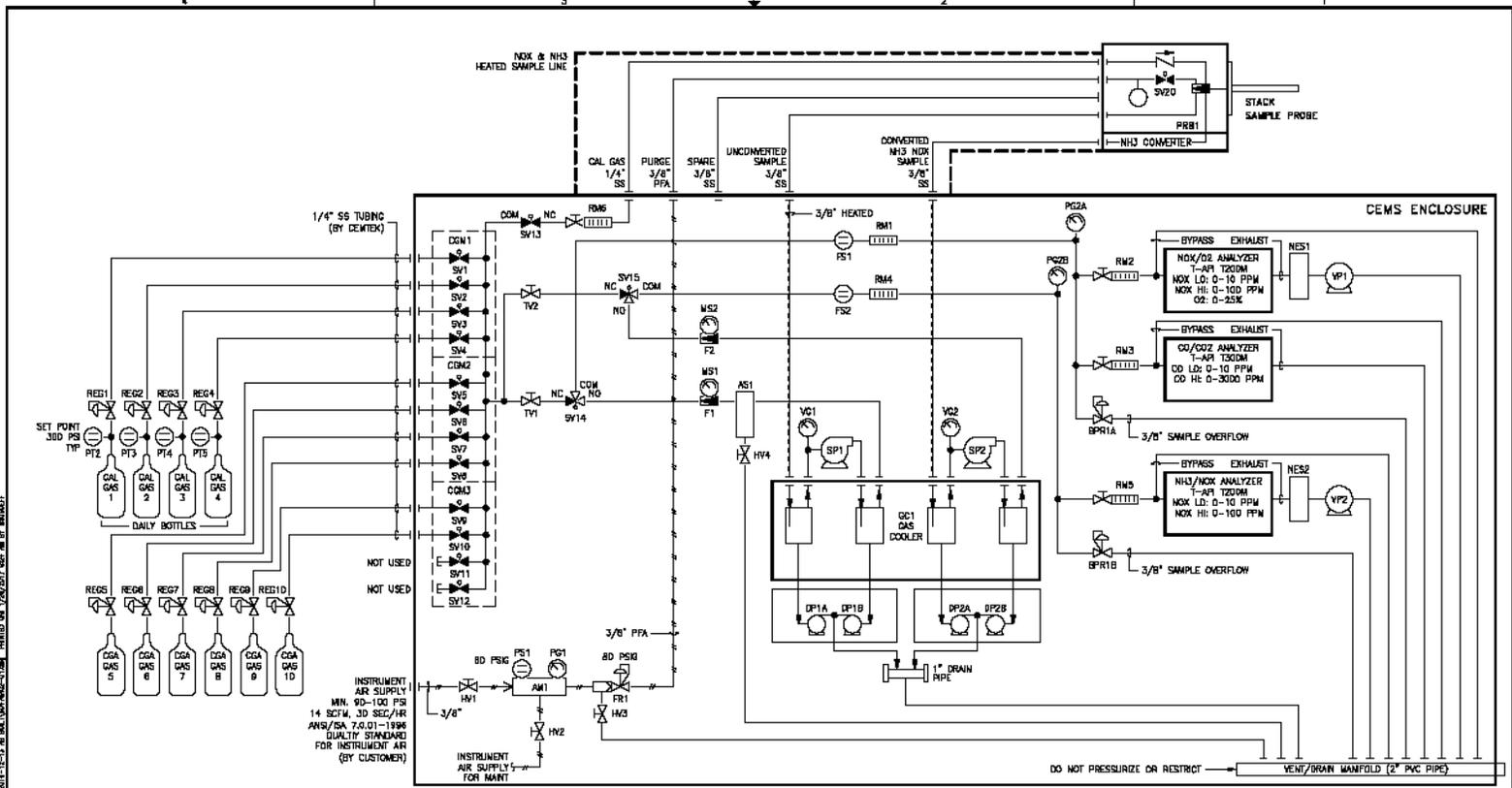

TYPICAL FOR UNITS 1 & 2

1. ALL TUBING SHALL BE 1/4" O.D. TEFLON.
NOTES UNLESS OTHERWISE SPECIFIED.



THIS DRAWING AND THE INFORMATION ON IT ARE PROPRIETARY AND THE PROPERTY OF CEMTEK ENVIRONMENTAL, INC. AND MAY NOT BE USED FOR REPRODUCTION, INSTALLATION OR OPERATION OF EQUIPMENT OR FOR OTHER REASONS WITHOUT WRITTEN CONSENT FROM CEMTEK ENVIRONMENTAL, INC.

NO.	REVISION	DATE	APPR. NO.	REVISION	DATE	APPR.
A	CUSTOMER COMMENTS	06/15/13	PT			
B	AS BUILT	12/15/13	PT			

ELECTRICAL IDENTIFICATION						
WIRE	SIZE	TYPE	INSULATION	MARKING	FUNCTION	NOTES
CONTROL	PVC	18 AWG	None	-	-	-
Signal	TEFLON	18 AWG	None	-	-	-
Power	TRN	14 AWG	None	-	-	-

SIEMENS ENERGY
CPV VALLEY ENERGY CENTER
MORAVIA, NY
CONTINUOUS EMISSIONS MONITORING SYSTEM
P.O. NO. 4302715182
CEMTEK PROJECT NO. CEM0475

STACK SAMPLE SYSTEM FLOW			
PROJECT: SIEMENS-CPV VALLEY	SCALE: N/A	SHEET: 1 OF 1	
OWNER: M. SUSEP	DATE: 07/18/13		
CLIENT: P. TRAN	DATE: 07/18/13		
APP: D. COLEMAN	DATE: 07/18/13		50478A02

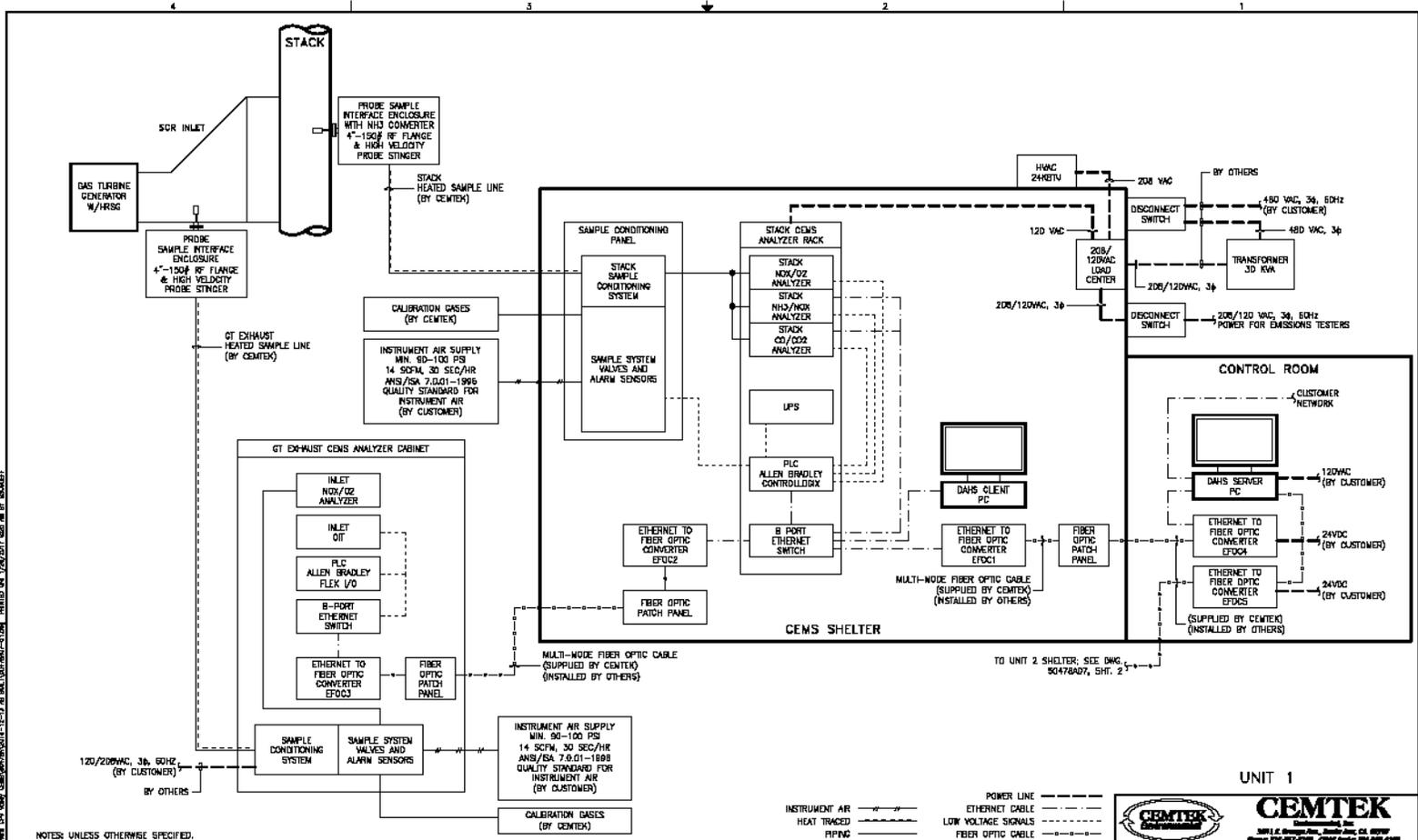

NOTES UNLESS OTHERWISE SPECIFIED.

NO.	REVISION	DATE	APPR. NO.	REVISION	DATE	APPR.
A	CUSTOMER COMMENTS	08/15/15	PT			
B	CUSTOMER COMMENTS 3	09/14/16	PT			
C	AS BUILT	12/18/18	PT			

ELECTRICAL SPECIFICATION			
WIRE	INS	SIZE	TYPE
CONTROL	PVC	18 AWG	NONE
POWER	TEFLON	18 AWG	NONE
POWER	TRNH	14 AWG	NONE

POWER LINE
 ETHERNET CABLE
 LOW VOLTAGE SIGNALS
 FIBER OPTIC CABLE

UNIT 1

CEMTEK
 Environmental
 301 E. Orange Ave., Suite 400, CA 92707
 Phone 714-962-4228, Cell 949-298-4888

SYSTEM BLOCK

PROJECT: SIEMENS-CPV VALLEY SCALE: W/A/1 SHT: 1 OF 2
 OWN: M. SUSOFF DATE: 07/18/15
 CKD: P. TRAN DATE: 07/18/15
 APP: D. COLEMAN DATE: 07/18/15

50478A07

THIS DOCUMENT IS THE PROPERTY OF CEMTEK. IT IS TO BE USED ONLY FOR THE PROJECT AND SITE SPECIFIC. NO PART OF THIS DOCUMENT IS TO BE REPRODUCED OR TRANSMITTED IN ANY FORM OR BY ANY MEANS, ELECTRONIC OR MECHANICAL, INCLUDING PHOTOCOPYING, RECORDING, OR BY ANY INFORMATION STORAGE AND RETRIEVAL SYSTEM.



CPV Valley Energy Center
50 Braintree Hill Office Park
Suite 300
Braintree, MA 02184

ATTACHMENT 6

Method of Compliance Form and Table

**New York State Department of Environmental Conservation
Air Permit Application**



DEC ID											
3	-	3	3	5	6	-	0	0	1	3	6

Methods Used to Determine Compliance			
Emission Unit ID	Applicable Requirement	Method Used to Determine Compliance	Compliance Date
Combustion Turbine - 1, 2		Short term emission limits are monitored by Continuous Emission Monitoring. Hourly data is submitted to the USEPA each quarter in the XML electronic data reports. In addition Excess Emission Reports are developed on CEM performance and characterize any excess emissions.	Upon Initial Certification of CEMS
Combustion Turbine - 1, 2		Annual emission limitations are monitored and reported in the Annual Emission Statement Report.	Each year by April 15
		A method of compliance determination analysis has been performed as part of the State Air Permit Conditions. A template of the Annual compliance certification is attached showing all methods of compliance for the facility.	Attached
			Attached

Condition Number	Applicable Requirement	Description of Requirement	Methods Used to Determine Compliance
DEC 1 item 1.1-1.3	ECL 19-0805	The permitted site or facility, including relevant records, is subject to inspection at reasonable hours and intervals by an authorized representative of the Department of Environmental Conservation.	Records will be made available.
DEC 2	ECL 3-0801.2(m)	Unless expressly provided for by the Department, issuance of this permit does not modify, supersede or rescind any order or determination previously issued by the Department or any of the terms, conditions or requirements contained in such order or determination.	No Previous issued orders for this facility.
DEC 3 item 3.1-3.3	6NYCRR 621.11	The permittee must submit a separate written application to the Department for renewal, modification or transfer of this permit. Required forms and supplemental information must be submitted. Any renewal, modification or transfer granted by the Department must be in writing. The renewal applications must be submitted at least 180 days before expiration, or at least 30 days before expiration of State Facility Permits. The permittee must submit a renewal application at least 180 days before expiration of permits for Title V Facility Permits, or at least 30 days before expiration of permits for State Facility Permits. Permits are transferable with the approval of the department unless specifically prohibited by the statute, regulation or another permit condition. Applications for permit transfer should be submitted prior to actual transfer of ownership.	Permit renewal will be made prior to 180 days of permit expiration.
DEC 4 item 4.1-4.3	6 NYCRR 62.1.11	The Department reserves the right to exercise all available authority to modify, suspend, or revoke this permit in accordance with 6NYCRR Part 62.1. The grounds for modification, suspension or revocation include: a) materially false or inaccurate statements in the permit application or supporting papers; b) failure by the permittee to comply with any terms or conditions of the permit; c) exceeding the scope of the project as described in the permit application; d) newly discovered material information or a material change in environmental conditions, relevant technology or applicable law or regulations since the issuance of the existing permit; e) non-compliance with previously issued permit conditions, orders of the commissioner, any provisions of the Environmental Conservation Law or regulations of the Department related to the permitted activity.	The Department reserves the right.
DEC 5	6NYCRR 621.13	Submission of applications for permit modification or renewal must be submitted to NYSDEC Region 3. NYSDEC Regional Permit Administrator Region 3 Headquarters Division of Environmental Permits 21 South Putt Corners Road New Paltz, NY 12561-1696 (845)256-3054	Submissions for modification or renewal will be submitted to the Regional and Albany offices.
Item A	6NYCRR 200.5	The commissioner may seal an air contamination source to prevent its operation if by compliance with 6NYCRR Chapter III is not met within the time provided by an order of the Commissioner issued in the case of the violation. Sealing means labeling or tagging a source to notify any person that operation of the source is prohibited, and also includes physical means of preventing the operation of an air contamination source without resulting in destruction of any equipment associated with such source, and includes, but is not limited to, bolting chaining or wiring shut control panels, apertures or conduits associated with such source. No person shall operate any air contamination source sealed by the Commissioner in accordance with this section unless a modification has been made which enables such source to comply with all requirements applicable to such modification. Unless authorized by the Commissioner, no person shall remove or alter any seal affixed to any contamination source in accordance with this section.	Facility will comply.
Item B	6NYCRR 200.6	Notwithstanding the provisions of 6NYCRR Chapter III, Subchapter A, no person shall allow or permit any air contamination source to emit air contaminants in quantities which alone or in combination with emissions from other air contamination sources would contravene any applicable ambient air quality standard and/or cause air pollution. In such cases where contravention occurs or may occur, the Commissioner shall specify the degree and/or method of emission control required.	Emissions are monitored and recorded by a certified CEMS following all applicable quality requirements.
Item C	6NYCRR 200.7	Any person who owns or operates an air contamination source which is equipped with an emission control device shall operate such device and keep it in a satisfactory state of maintenance and repair in accordance with ordinary and necessary practices, standards and procedures, inclusive of manufacturers specifications, required to operate such device effectively.	Devices are operated and maintained in accordance with specified instructions.
Item D	6NYCRR 201-1.2	If an existing emission source was subject to the permitting requirements of 6NYCRR Part 201 at the time of construction or modification, and the owner and/or operator failed to apply for a permit for such emission source then the following provisions apply: (a) The owner and/or operator must apply for a permit for such emission source or register the facility in accordance with the provisions of Part 201. (b) The emission source or facility is subject to all regulations that were applicable to it at the time of construction or modification and any subsequent requirements applicable to existing sources or facilities.	The facility applied for all permits that were applicable to it at the time of construction.
Item E	6NYCRR 201-1.5	An emergency constitutes an affirmative defense to an action brought for non-compliance with emissions limitations or permit conditions for all facilities in New York State. (a) The affirmative defense of emergency shall be demonstrated through properly signed, contemporaneous operating logs, or other relevant evidence that (1) An emergency occurred and that the facility owner and/or operator can identify the cause(s) of the emergency; (2) The equipment at the permitted facility causing the emergency was at the time being properly operated; (3) During the period of the emergency the facility owner and/or operator took all reasonable steps to minimize levels of emissions that exceeded the emission standards, or other requirements in the permit; and (4) The facility owner and/or operator notified the Department within two working days after the event occurred. This notice must contain a description of the emergency, any steps taken to mitigate emissions, and corrective actions taken. (b) In any enforcement proceeding, the facility owner and/or operator seeking to establish the occurrence of an emergency has the burden of proof. (c) This provision is in addition to any emergency or upset provision contained in any applicable requirement.	The affirmative defense provisions will be utilized when appropriate.
Item F	6NYCRR 201-1.7	Where practical, any person who owns or operates an air contamination source shall recycle or salvage air contaminants collected in an air cleaning device according to the requirements of 6NYCRR.	Recycling of air contaminants practiced if applicable and when practical.
Item G	6NYCRR 201-1.8	No person shall unnecessarily remove, handle, or cause to be handled, collected air contaminants from an air cleaning device for recycling, salvage or disposal in a manner that would reintroduce them to the outdoor atmosphere.	Air cleaning devices salvaged or disposed of to prevent reintroduction to the atmosphere if applicable.
Item H	6NYCRR 201-3.2(a)	The owner and/or operator of an emission source or unit that is eligible to be exempt, may be required to certify that it operates within the specific criteria described in 6NYCRR Subpart 201-3. The owner or operator of any such emission source must maintain all required records on-site for a period of five years and make them available to representatives of the Department upon request. Department representatives must grant access to any facility which contains emission sources or units subject to 6NYCRR Subpart 201-3, during normal operating hours, for the purpose of determining compliance with this and any other state and federal air pollution control requirements, regulations, or law.	Records will be maintained for 5 years.

Condition Number	Applicable Requirement	Description of Requirement	Methods Used to Determine Compliance
Item I	6NYCRR 201-3.3(a)	The owner and/or operator of an emission source or unit that is listed as being trivial in 6NYCRR Part 201 may be required to certify that it operates within the specific criteria described in 6NYCRR Subpart 201-3. On-site for a period of five years and make them available to representatives of the Department upon request. Department representatives must grant access to any facility which contains emission sources or units subject to 6NYCRR Subpart 201-3, during normal operating hours, for the purpose of determining compliance with this and any other state and federal air pollution control requirements, regulations, or law.	Records will be maintained for 5 years.
Item J	6NYCRR 202.1.1	An acceptable report of measured emissions shall be submitted, as may be required by the Commissioner, to ascertain compliance or non-compliance with any air pollution code, rule, or regulation. Failure to submit a report acceptable to the Commissioner within the time stated shall be sufficient reason for the Commissioner to suspend or deny an operating permit. Notification and acceptable procedures are specified in 6NYCRR Subpart 202-1.	Reports are submitted.
Item K	6NYCRR 215.2	Except as allowed by section 215.3 of 6NYCRR Part 215, no person shall burn, cause, suffer, allow or permit the burning of any materials in an open fire.	No Open Fires allowed onsite.
Item L	ECL 19-0305	The issuance of this permit by the Department and the receipt thereof by the Applicant does not and shall not be construed as barring, diminishing, adjudicating or in any way affecting any legal, administrative or equitable rights or claims, actions, suits, causes of action or demands whatsoever that the Department may have against the Applicant for violations based on facts and circumstances alleged to have occurred or existed prior to the effective date of this permit, including, but not limited to, any enforcement action authorized pursuant to the provisions of applicable federal law, the ECL and Chapter III of the NYCRR. The issuance of this permit also shall not in any way affect pending or future enforcement actions under the Clean Air Act brought by the United States or any person.	Issuance of permit does not affect enforcement actions.
Item M	40 CFR 70.6 (b)	All terms and conditions in this permit required by the act or any applicable requirement, including any provisions designed to limit a facility's potential to emit, are enforceable by the Administrator and citizens under the act. The Department has, in this permit, specifically designed any terms and conditions that are not required under the act or under any of its applicable requirements as being enforceable under only state regulations.	Permit conditions are enforceable.
1	NYCRR 200.7	Any person who owns or operates an air contamination source which is equipped with an emission control device shall operate such device and keep it in a satisfactory state of maintenance and repair in accordance with ordinary and necessary practices, standards and procedures, inclusive of manufacturers specifications, required to operate such a device effectively.	Emission control devices shall be operated in accordance with ordinary and necessary practices.
2	6NYCRR 202-1.1	For the purpose of ascertaining compliance or non-compliance with any air pollution control code, rule or regulation, the Commissioner may require the person who owns such air contamination source to submit an acceptable report of measured emissions within a stated time.	Reports will be submitted when required.
3	6NYCRR 200.7	The facility will maintain records to verify concentration of ammonia stored on-site is less than 19%.	Ammonia information will be maintained.
4	6NYCRR 200.7	The facility shall install, calibrate, maintain and operate a continuous emissions monitors for ammonia. The 5.0 ppmvd corrected to 15% Oxygen limit applies during all turbine loads, all fuels being fired and all duct burner operations.	Continuous Emissions Monitoring (CEM). Any exceedances during the reporting period were reported in quarterly CEMS Performance and Excess Emissions Reports.
5	6NYCRR 201-1.4(a)	The owner or operator shall, within one year following the commencement of operation, submit a Title V permit application to the department (as per the requirements of paragraph 201-6.3(a)(3)). This application must include start-up, shutdown, and fuel switching data to establish enforceable combustion turbine start-up, shutdown and fuel switching emission rates for NOx, CO, and NH3, and confirm that such established rates would not result in a violation of applicable NAAQS. In the event that a minimum of 15 start-ups and 15 shutdowns, while firing distillate oil, does not occur within the one year period defined above, the owner or operator will be required to submit start-up and shutdown data, with an application for permit modification, once the 15 start-ups and shutdowns while firing distillate oil occur. Also, if a minimum of 15 fuel switches does not occur within the one year period defined above, the owner or operator will be required to submit fuel switching data with an application for permit modification once the 15 fuel switches occur.	The condition will be followed.
6	6NYCRR 201-6.3(a)(2)	The Title V permit application must be submitted to the Department within one year of commencement of operation of this facility.	The Title V will be submitted within one year of commencement of operation.
7	6NYCRR Subpart 201-7	The sum of emissions from the emission units specified in this permit shall not equal or exceed the following Potential To Emit (PTE) rate for each regulated contaminant: PM 2.5 = 190,000 pounds per year	Emissions shall not exceed applicable limit.
8	6NYCRR Subpart 201-7	Under the authority of 6NYCRR Part 201-7, this condition contains an emission cap for the purpose of limiting emissions from the facility, emission unit or process to avoid being subject to the following applicable requirement(s) that the facility, emission unit or process would otherwise be subject to: 6NYCRR 231-2.2	Condition will be followed.
8 (continued)	6NYCRR 231-2.2	Operation of this facility shall take place in accordance with the approved criteria, emission limits, terms, conditions and standards in this permit.	Operation will comply.
8 (continued)	6NYCRR 231-2.2	The owner or operator of the permitted facility must maintain all required records on-site for a period of five years and make them available to representatives of the Department upon request. Department representatives must be granted access to any facility regulated by the Subpart, during normal operating hours, for the purpose of determining compliance with this and any other state and federal air pollution control requirements, regulations or law.	Recordkeeping requirements maintained at the facility for a period of 5 years.
8 (continued)	6NYCRR 231-2.2	On an annual basis, unless otherwise specified below, beginning one year after the granting of an emissions cap, the responsible official shall provide a certification to the Department that the facility has operated all emission units within the limits imposed by the emission cap. This certification shall include a brief summary of the emissions subject to the cap for that time period and a comparison to the threshold levels that would require compliance with an applicable requirement.	Certification will be submitted.
8 (continued)	6NYCRR 231-2.2	The emission of pollutants that exceed the applicability thresholds for an applicable requirement, for which the facility has obtained an emissions cap, constitutes a violation of Part 201 and of the Act.	Emission caps will be adhered to.
8 (continued)	6NYCRR 231-2.2	The Compliance Demonstration activity will be performed for the Facility. Regulated contaminants: CAS No: 0NY075-02-5 PM 2.5	Compliance demonstration shall be performed.
8 (continued)	6NYCRR 231-2.2	Monthly facility-wide emissions of PM2.5 will be calculated as the sum of monthly PM2.5 emissions from individual emission units or source groups. Emissions will be calculated based on heat input (or, equivalently, from fuel use) and emission factors as described below. Annual facility-wide emissions will then be determined at the end of each month on a rolling 12-month basis in order to demonstrate compliance with the 95 ton per year cap. The source groups included in the emissions cap along with their associated source indices and PM2.5 emission factors, as used in subsequent equations, are listed in the following. For each source group, the parameter that will be monitored and the monitoring frequency. Continuous monitoring of heat input to the combustion turbines, auxiliary boiler and gas heaters will be provided by a digital data acquisition system (DAS)	Calculation shall be performed in accordance with the condition,
		95 Tons Heat Input per year	

Condition Number	Applicable Requirement	Description of Requirement	Methods Used to Determine Compliance
9	6NYCRR 211.1	No person shall cause or allow emission of air contaminants to the outdoor atmosphere of such quantity, characteristic or duration which are injurious to human, plant or animal life or to property, or which unreasonably interfere with the comfortable enjoyment of life or property. Notwithstanding the existence of specific air quality standards or emission limits, this prohibition applies, but is not limited to, any part	Condition shall be followed.
10	6NYCRR 231-5.3	Facility wide potential to emit VOC 65 tons/yr NOx 186.8 tons/yr	PTE Thresholds.
11	6NYCRR 231-5.4	Emission Unit: U-00001 Emission Point: EP001 Process: P1A; Emission Unit: U-00001 Emission Point: EP001 Process: P2A; Emission Unit: U-00002 Emission Point: EP002 Regulated Contaminant(s): CAS No: 0NY2 10-00-0 OXIDES OF NITROGEN Process: P01; Emission Unit: U-00002 Process: P02 Emission Point: EP002 LAER is 2.0 ppmvd corrected to 15% O ₂ . Will be achieved through use of Dry Low NO _x combustion technology and SCR. The facility shall install, calibrate, maintain, and operate a continuous emission monitor. The limit applies at all loads except during start up and shutdown.	Continuous Emissions Monitoring (CEM). Any exceedances during the reporting period were reported in quarterly CEMS Performance and Excess Emissions Reports.
12	6NYCRR 231-5.4	Emission Unit: U-00001 Process: P2A Emission Point: EP001; Emission Unit: U-00002 Process: P02 Emission Point: EP002; Regulated Contaminant(s): CAS No: 0NY98-00-0 VOC LAER is 1.8 ppmvd corrected to 15% O ₂ . Will be achieved using good combustion controls and an oxidation catalyst. Emission testing to be performed within 180 days of startup.	LAER Demonstration shall be performed.
13	6NYCRR 231-5.4	Emission Unit: U-00001 Emission Point: EP001 Process: P3A; Emission Unit: U-00002 Process: P03 Emission Point: EP002; Regulated Contaminant(s): CAS No: 0NY2 10-00-0 OXIDES OF NITROGEN LAER is 6.0 ppmvd corrected to 15% O ₂ . Will be achieved using water injection and SCR. The facility shall install, calibrate, maintain, and operate a continuous emission monitor. The limit applies at all loads except during start up and shutdown.	Continuous Emissions Monitoring (CEM). Any exceedances during the reporting period were reported in quarterly CEMS Performance and Excess Emissions Reports.
14	6NYCRR 231-5.4	Emission Unit: U-00001 Process: P1A Emission Point: EP001; Emission Unit: U-00001 Process: P3A Emission Point: EP001; Emission Unit: U-00002 Process: P01 Emission Point: EP002; Emission Unit: U-00002 Process: P01 Emission Point: EP002 LAER is 0.7 ppmvd corrected to 15% O ₂ . Will be achieved using good combustion controls and an oxidation catalyst. Emission testing to be performed within 180 days of startup.	LAER Demonstration shall be performed.
15	6NYCRR 231-5.5	The potential to emit Oxides of Nitrogen (NO _x) from the facility has been limited to 187 tons per year. NO _x emissions must be offset at a ratio of 1.15 to 1. A total of 216 tons of offsets will be required. The facility will identify the sources of offsets at a later time but prior to construction. There will be a separate noticing at that time.	Emission offset requirements shall be met.
16	6NYCRR 231-5.5	The potential to emit Volatile Organic Compounds (VOC) from the facility has been limited to 65 tons per year. VOC emissions must be offset at a ratio of 1.15 to 1. A total of 75 tons of offsets will be required. The facility will identify the sources of offsets at a later time but prior to construction. There will be a separate noticing at that time.	Emission offset requirements shall be met.
17	6NYCRR 231-5.5	INVALID FORMAT OF CONDITION IN LIBRARY	NA
18	6NYCRR 231-7.5	Facility-Wide Potential to Emit CO 344 tons/yr SO ₂ 42 tons/yr PM-2.5 95 tons/yr H ₂ SO ₄ 13 tons/yr CO ₂ 2,164,438 tons/yr	Limits are in place.
19	6NYCRR 231-7.6	The combined cycle units shall have a heat rate of 7605 Btu/kW-hr (HHV) or less at ISO conditions without duct burner firing to achieve a design thermal efficiency of 57.4% (LHV). Within 90 days of start-up of the facility and on an annual basis thereafter, the owner or operator shall conduct a Department approved heat rate performance test on a combined cycle unit while it is operating at maximum load to determine heat rate.	Intermittent Emissions Testing. Heat Rate testing was conducted on May 8th, 2018.
20	6NYCRR 231-7.5	The owner or operators of the facility shall calculate the annual emissions (based on a monthly rolling average) of Carbon Dioxide equivalent (CO ₂ e) emitted from the facility. The Emissions factors will be based on either performance tests (as required by the permit) or developed emission factors from authorized sources (i.e. AP-42). Fuel usage shall be monitored by fuel flow meters. The information will be kept on-site and available for review for a minimum of five years. The facility will keep on-site records for up to five years.	Record Keeping/Maintenance Procedures. CO ₂ emissions are continuously calculated in the CEMS using 40 CFR 75 Appendices D and G
21	6NYCRR 231-7.6	This facility shall install, calibrate, maintain and operate a continuous emissions monitor for oxides of nitrogen. This limit shall apply only during periods of start-up (30 minutes per occurrence). Emissions in excess of this limit shall be reported quarterly through the facility's excess emissions report. All records shall be maintained by the applicant at their Polett facility for a minimum of five years. Manufacturer Name/Model Number: NO _x Analyzer Parameter Monitored: OXIDES OF NITROGEN Upper Permit Limit: 15.0 pounds	Record Keeping/Maintenance Procedures. CO ₂ emissions are continuously calculated in the CEMS using 40 CFR 75 Appendices D and G
22	6NYCRR 231-7.6	BACT FUEL SULFUR LIMIT OF 0.0015% BY WEIGHT.	Work Practice Involving Specific Operations. ULSD Certifications on files for deliveries received.
23	6NYCRR 231-7.6	BACT is 0.002 lb/mmBtu. Will be achieved through use of low sulfur fuels. Emission testing to be performed within 180 days of startup.	BACT demonstration shall be performed.
24	6NYCRR 231-7.6	BACT is 0.0007 lb/mmBtu. Will be achieved through use of low sulfur fuels. Emission testing to be performed within 180 days of startup.	BACT demonstration shall be performed.
25	6NYCRR 231-7.6	BACT is 0.0005 lb/mmBtu. Will be achieved through use of low sulfur. Emission testing to be performed within 180 days of startup.	BACT demonstration shall be performed.
26	6NYCRR 231-7.6	BACT is 0.0015 lb/mmBtu. Will be achieved through use of low sulfur fuels. Emission testing to be performed within 180 days of startup.	BACT demonstration shall be performed.
27	6NYCRR 231-7.6	BACT is 0.0368 lb/mmBtu. Will be achieved through use of low sulfur fuels. Emission testing to be performed within 180 days of startup.	BACT demonstration shall be performed.
28	6NYCRR 231-7.6	BACT is 3.4 ppmvd corrected to 15% Oxygen. Will be achieved through good combustion controls and an oxidation catalyst. The facility shall install, calibrate, maintain, and operate a continuous emission monitor. The limit applies at all loads except during start up and shutdown.	Continuous Emissions Monitoring (CEM). Any exceedances during the reporting period were reported in quarterly CEMS Performance and Excess Emissions Reports.
29	6NYCRR 231-7.6	BACT is 0.0073 lb/mmBtu. Will be achieved through use of low sulfur fuels. Emission testing to be performed within 180 days of startup.	BACT demonstration shall be performed.
30	6NYCRR 231-7.6	BACT is 2.0 ppmvd corrected to 15% Oxygen. Will be achieved through good combustion controls and an oxidation catalyst. The facility shall install, calibrate, maintain, and operate a continuous emission monitor. The limit applies at all loads except during start up and shutdown.	Continuous Emissions Monitoring (CEM). Any exceedances during the reporting period were reported in quarterly CEMS Performance and Excess Emissions Reports.

Condition Number	Applicable Requirement	Description of Requirement	Methods Used to Determine Compliance
31	6NYCRR 243-1.6(a)	The CAIR designated representative of each CAIR NOx Ozone Season source shall: (i) submit to the department a complete CAIR permit application under section 243-3.3 in accordance with the deadlines specified in section 243-3.2; and (ii) submit in a timely manner any supplemental information that the department determines is necessary in order to review a CAIR permit application and issue or deny a CAIR permit. The owners and operators of each CAIR NOx Ozone Season source shall have a CAIR permit issued by the department under Subpart 243-3 for the source and operate the source and the unit in compliance with such CAIR permit.	The AAR of the NOx Budget permit submitted applicable applications for the facility in accordance with 243-1.6.
32	6NYCRR 243-1.6(b)	The emissions measurements recorded and reported in accordance with Subpart 243-8 shall be used to determine compliance by each CAIR NOx Ozone Season source with the CAIR NOx Ozone Season emissions limitation under subdivision (c) of this section.	The Continuous Emission Monitoring System operates in compliance with 40 CFR Part 75. Electronic Data Reports (EDR) are submitted electronically each quarter.
33	6NYCRR 243-1.6(c)	As of the allowance transfer deadline for a control period the owners and operators of each CAIR NOx Ozone Season source and each CAIR NOx Ozone Season unit at the source shall hold in the source's compliance account, CAIR NOx Ozone Season allowances available for compliance deductions for the control period under section 243-6.5(a) in an amount not less than the tons of total nitrogen oxides emissions for the control period from all CAIR NOx Ozone Season units at the source, as determined in accordance with Subpart 243-8. The CAIR NOx ozone season is the period beginning May 1 of a calendar year, except as provided in section 243-1.6(c)(2), and ending on September 30 of the same year, inclusive.	The CAIR NOx Ozone Season compliance account shall meet the requirements of Subpart 243-1.6(c)(2), 243-6.5(a), 243-8.
34	6NYCRR 243-1.6(d)	If a CAIR NOx Ozone Season source emits nitrogen oxides during any control period in excess of the CAIR NOx Ozone Season emissions limitation, then: (1) the owners and operators of the source and each CAIR NOx Ozone Season unit at the source shall surrender the CAIR NOx Ozone Season allowances required for deduction under section 243-6.5(d)(i) and pay any fine, penalty, or assessment or comply with any other remedy imposed; or the same violations, under the Act or applicable State law; and (2) each ton of such excess emissions and each day of such control period shall constitute a separate violation of this Subpart, the Act, and applicable State law.	The CAIR NOx Ozone Season compliance account shall meet the requirements of Subpart 243-6.5(d).
35	6NYCRR 243-1.6(e)	Unless otherwise provided, the owners and operators of the CAIR NOx Ozone Season source and each CAIR NOx Ozone Season unit at the source shall keep on site at the source each of the following documents for a period of five years from the date the document is created. This period may be extended for cause, at any time before the end of five years, in writing by the department or the Administrator. (i) The certificate of representation under section 243-2.4 for the CAIR designated representative for the source and each CAIR NOx Ozone Season unit at the source and all documents that demonstrate the truth of the statements in the certificate of representation; provided that the certificate and documents shall be retained on site at the source beyond such five-year period until such documents are superseded because of the submission of a new certificate of representation under section 243-2.4 changing the CAIR designated representative. (ii) All emissions monitoring information, in accordance with Subpart 243-8, provided that to the extent that Subpart 243-8 provides for a three-year period for record keeping, the three-year period shall apply. (iii) Copies of all reports, compliance certifications, and other submissions and all records made or required under the CAIR NOx Ozone Season Trading Program. (iv) Copies of all documents used to complete a CAIR permit application and any other submission under the CAIR NOx Ozone Season Trading Program or to demonstrate compliance with the requirements of the CAIR NOx Ozone Season Trading Program.	The documents will be kept onsite at the facility.
36	6NYCRR 243-2.1	Except as provided under section 243-2.2, each CAIR NOx Ozone Season source, including all CAIR NOx Ozone Season units at the source, shall have one and only one CAIR designated representative with regard to all matters under the CAIR NOx Ozone Season Trading Program concerning the source or any CAIR NOx Ozone Season unit at the source. The CAIR designated representative of the CAIR NOx Ozone Season source shall be selected by an agreement binding on the owners and operators of the source and all CAIR NOx Ozone Season units at the source and shall act in accordance with the certification statement in section 243-2.4(a)(4)(iv). Upon receipt by the Administrator of a complete certificate of representation under section 243-2.4, the CAIR designated representative of the source shall represent and by his or her representations, actions, in actions or submissions, legally bind each owner and operator of the CAIR NOx Ozone Season source represented and each CAIR NOx Ozone Season unit at the source in all matters pertaining to the CAIR NOx Ozone Season Trading Program, notwithstanding any agreement between the CAIR designated representative and such owners and operators. The owners and operators shall be bound by any decision or order issued to the CAIR designated representative by the department, the Administrator, or a court regarding the source or unit. No CAIR permit will be issued, no emissions data reports will be accepted, and no CAIR NOx Ozone Season Allowance Tracking System account will be established for a CAIR NOx Ozone Season unit at a source, until the Administrator has received a complete certificate of representation under section 243-2.4 for a CAIR designated representative of the source and the CAIR NOx Ozone Season units at the source. Each submission under the CAIR NOx Ozone Season Trading Program shall be submitted signed, and certified by the CAIR designated representative for each CAIR NOx Ozone Season source on behalf of which the submission is made. Each such submission shall include the following certification statement by the CAIR designated representative: "I am authorized to make this submission on behalf of the owners and operators of the source or units for which the submission is made. I certify under penalty of law that I have personally examined, and am familiar with, the statements and information submitted in this document and all its attachments. Based on my inquiry of those individuals with primary responsibility for obtaining the information, I certify that the statements and information are to the best of my knowledge and belief true, accurate, and complete. I am aware that there are significant penalties for submitting false statements and information or omitting required statements and information, including the possibility of one or imprisonment."	The CAIR NOx Ozone Season representative will comply with 243-2.1 and will submit the applicable documents as required.
37	6NYCRR 243-2.4	Unless otherwise required by the department or the Administrator, documents of agreement referred to in the certificate of representation shall not be submitted to the department or the Administrator. Neither the department nor the Administrator shall be under any obligation to review or evaluate the sufficiency of such documents, if submitted.	The department and Administrator are not obligated to review documents referred to in the certificate of representation.
38	6NYCRR 243-8.1	The owners and operators, and to the extent applicable, the CAIR designated representative, of a CAIR NOx Ozone Season unit, shall comply with the monitoring, record keeping and reporting requirements as provided in this Subpart and in Subpart H of 40CFR Part 75. For purposes of complying with such requirements, the definitions in section 243-1.2 and in 40CFR 72.2 shall apply, and the terms "affected unit," "designated representative," and "continuous emission monitoring system" (or "CEMS") in 40CFR Part 75 shall be deemed to refer to the terms "CAIR NOx Ozone Season unit," "CAIR designated representative," and "continuous emission monitoring system" (or "CEMS") respectively, as defined in section 243-1.2. The owner or operator of a unit that is not a CAIR NOx Ozone Season unit but that is monitored under 40CFR 75.72(b)(2)(ii) shall comply with the same monitoring, record keeping, and reporting requirements as a CAIR NOx Ozone Season unit. Requirements for installation, certification, and data accounting. The owner or operator of each CAIR NOx Ozone Season unit shall: (1) install all monitoring systems required under this Subpart for monitoring NOx mass emissions and individual unit heat input including all systems required to monitor NOx emission rate, NOx concentration, stack gas moisture content, stack gas flow rate, CO2 or O2 concentration, and fuel flow rate, as applicable, in accordance with 40CFR 75.71 and 40CFR 75.72; (2) successfully complete all certification tests required under section 243-8.2 and meet all other requirements of this Subpart and 40CFR Part 75 applicable to the monitoring systems under paragraph (a)(1) of this section; and (3) record, report, and quality-assure the data from the monitoring systems under paragraph (a)(1) of this section.	The owner and operators will install and certify the required monitoring systems. The emission data will be recorded, reported and quality assured.

Condition Number	Applicable Requirement	Description of Requirement	Methods Used to Determine Compliance
39	6NYCRR 243-8.1	No owner or operator of a CAIR NOx Ozone Season unit shall use any alternative monitoring system, alternative reference method, or any other alternative to any requirement of this Subpart without having obtained prior written approval in accordance with section 243-8.6. No owner or operator of a CAIR NOx Ozone Season unit shall operate the unit so as to discharge, or allow to be discharged, NOx emissions to the atmosphere without accounting for all such emissions in accordance with the applicable provisions of this Subpart and 40CFR Part 75. No owner or operator of a CAIR NOx Ozone Season unit shall disrupt the continuous emission monitoring system, any portion thereof, or any other approved emission monitoring method, and there by avoid monitoring and recording NOx mass emissions discharged into the atmosphere or heat input, except for periods of recertification or periods when calibration, quality assurance testing, or maintenance is performed in accordance with the applicable provisions of this Subpart and 40CFR Part 75. No owner or operator of a CAIR NOx Ozone Season unit shall retire or permanently discontinue use of the continuous emission monitoring system, any component thereof, or any other approved monitoring system under this Subpart, except under any one of the following circumstances: (i) during the period that the unit is covered by an exemption under section 243-1.5 that is in effect; (ii) the owner or operator is monitoring emissions from the unit with another certified monitoring system approved in accordance with the applicable provisions of this Subpart and 40CFR Part 75, by the department for use at that unit that provides emission data for the same pollutant or parameter as the retired or discontinued monitoring system; or (iii) the CAIR designated representative submits notification of the date of certification testing of a replacement monitoring system for the retired or discontinued monitoring system in accordance with section 243-8.2(d)(3)(i).	The facility utilizes a certified CEMS to monitor emission in accordance with 243-8.1 and 40 CFR Part 75. AAR submits information in accordance with applicable requirements.
40	NYCRR 243-8.5(d)	The CAIR designated representative shall submit quarterly reports, as follows: If the CAIR NOx Ozone Season unit is subject to an Acid Rain emissions limitation or a CAIR NOx emissions limitation or if the owner or operator of such unit chooses to report on an annual basis under this Subpart, the CAIR designated representative shall meet the requirements of Subpart H of 40CFR Part 75 (concerning monitoring of NOx mass emissions) for such unit for the entire year and shall report the NOx mass emissions data and heat input data for such unit in an electronic quarterly report in a format prescribed by the Administrator, for each calendar quarter beginning with: (i) for a unit that commences commercial operation before July 1, 2007, the calendar quarter covering May 1, 2008 through June 30, 2008; (ii) for a unit that commences commercial operation on or after July 1, 2007, the calendar quarter corresponding to the earlier of the date of provisional certification or the applicable deadline for initial certification under section 243-8.1(b), unless that quarter is the third or fourth quarter of 2007 or the first quarter of 2008, in which case reporting shall commence in the quarter covering May 1, 2008 through June 30, 2008. The CAIR designated representative shall submit each quarterly report to the Administrator within 30 days following the end of the calendar quarter covered by the report. Quarterly reports shall be submitted in the manners specified in 40CFR 75.73(f). For CAIR NOx Ozone Season units that are also subject to an Acid Rain emissions limitation or the CAIR NOx Annual Trading Program, CAIR SO2 Trading Program, or the Mercury Reduction Program for Coal-Fired Electric Utility Steam Generating Units (6NYCRR Part 246), quarterly reports shall include the applicable data and information required by Subparts F through I of 40 CFR Part 75 as applicable, in addition to the NOx mass emission data, heat input data, and other information required by this Subpart.	Continuous Emissions Monitoring (CEM). Quarterly reports were submitted electronically to EPA by the reporting deadline.
41	NYCRR 243-8.5(e)	The CAIR designated representative shall submit to the Administrator a compliance certification (in a format prescribed by the Administrator) in support of each quarterly report based on reasonable inquiry of those persons with primary responsibility for ensuring that all of the unit's emissions are correctly and fully monitored. The certification shall state that: (1) the monitoring data submitted were recorded in accordance with the applicable requirements of this Subpart and 40CFR Part 75, including the quality assurance procedures and specifications; (2) for a unit with add-on NOx emission controls and for all hours where NOx data are substituted in accordance with 40CFR 75.34(a)(1), the add-on emission controls were operating within the range of parameters listed in the quality assurance/quality control program under appendix B to 40CFR Part 75 and the substitute data values do not systematically underestimate NOx emissions; and (3) for a unit that is reporting on a control period basis under subparagraph (d)(2)(ii) of this section, the NOx emission rate and NOx concentration values substituted for missing data under Subpart D of 40CFR Part 75 are calculated using only values from a control period and do not systematically underestimate NOx emissions.	Reports are submitted in accordance with 40 CFR Part 75.
42	NYCRR Subpart 244-1	1) As of midnight of March 1, or midnight of the first business day thereafter if March 1 is not a business day, the owners and operators shall hold in their compliance account, Clean Air Interstate Rule (CAIR) NOx allowances available for compliance deductions for the previous control period, January 1 through December 31, in an amount not less than the total tons of nitrogen oxides emissions from all CAIR NOx units at the source during that control period. A CAIR NOx allowance shall not be deducted for a control period in a calendar year before the year for which the CAIR NOx allowance was allocated. [244-1.6(c)(1), 244-1.2(b)(5), 244-1.2(b)(3)(6), 244-1.6(c)(3)] 2) The owners and operators shall hold in their compliance account, CAIR NOx allowances available for compliance deductions for the control period starting on the later of January 1, 2009 or the deadline for meeting a CAIR NOx unit's monitor certification requirements under section 244-8.1(b)(1), (2), or (5) and for each control period thereafter. [244-1.6(c)(2)] 3) If a CAIR NOx source emits nitrogen oxides during any control period in excess of the CAIR NOx emissions limitation, the owners and operators of the CAIR NOx source shall surrender the CAIR NOx allowances required for deduction under 6NYCRR Part 244-6.5(d)(1) and pay a fine, penalty, or assessment or comply with any other remedy imposed for the same violations, under the Act or applicable State law. Each ton of such excess emissions and each day of such control period shall constitute a separate violation of this permit, the Act, and applicable State law. [244-1.6(d)] 4) Unless otherwise provided, the owners and operators of the CAIR NOx source shall keep onsite each of the following documents for a period of five years, in writing by the department or the Administrator: [244-1.6(e)] (i) The certificate of representation under 6NYCRR Part 244-2.4 for the CAIR designated representative for the source and all documents that demonstrate the truth of the statements in the certificate of representation; provided that the certificate and documents shall be retained onsite at the source beyond such five year period until such documents are superseded because of the submission of a new certificate of representation under 6NYCRR Part 244-2.4 changing the CAIR designated representative. (ii) All emissions monitoring information, in accordance with 6NYCRR Part 244-8; provided that to the extent that 6NYCRR Part 244-8 provides for a three year period for record keeping, the three year period shall apply. (iii) Copies of all reports, compliance certifications, and other submissions and all records made or required under the CAIR NOx Annual Trading Program. (iv) Copies of all documents used to complete a CAIR permit application and any other submission under the CAIR NOx Annual Trading Program or to demonstrate compliance with the requirements of the CAIR NOx Annual Trading Program.	The documents will be kept onsite at the facility.
43	NYCRR Subpart 244-2	1) Each Clean Air Interstate Rule (CAIR) NOx source shall have one CAIR designated representative and may have one alternate representative, as per 6NYCRR Part 244-2.2, with regard to all matters under the CAIR NOx Annual Trading Program. The CAIR designated representative shall be selected by an agreement binding on the owners and operators of the source and act in accordance with the certification statement in 6NYCRR Part 244-2.4(a)(4)(iv). Upon receipt by the Administrator of a complete certificate of representation under 6NYCRR Part 244-2.4, the CAIR designated representative of the source shall be present and, by his or her representations, actions, inactions, or submissions, legally bind each owner and operator of the CAIR NOx source represented in all matters pertaining to the CAIR NOx Annual Trading Program, notwithstanding any agreement between the CAIR designated representative and such owners and operators. The owners and operators shall be bound by any decision or order issued to the CAIR designated representative by the department, the Administrator, or a court regarding the source. [244-2.1(a), (b) & (c)] (2) Each submission under the CAIR NOx Annual Trading Program shall be submitted, signed, and certified by the CAIR designated representative for each CAIR NOx source on behalf of which the submission is made. Each such submission shall include the following certification statement by the CAIR designated representative: "I am authorized to make this submission on behalf of the owners and operators of the source or units for which the submission is made. I certify under penalty of law that I have personally examined, and am familiar with, the statements and information submitted in this document and all its attachments. Based on my inquiry of those individuals with primary responsibility for obtaining the information, I certify that the statements and information are to the best of my knowledge and belief true, accurate, and complete. I am aware that there are significant penalties for submitting false statements and information or omitting required statements and information, including the possibility of one or imprisonment." [244-2.1(e)]	Reports are submitted in accordance with 40 CFR Part 75.

Condition Number	Applicable Requirement	Description of Requirement	Methods Used to Determine Compliance
44	6NYCRR Subpart 244-8	<p>Regulated Contaminants): CAS No. 0NY210-00-0 OXIDES OF NITROGEN</p> <p>(1) The owners and operators, and to the extent applicable, the CAIR designated representative shall comply with all recordkeeping and reporting requirements in this condition, the applicable recordkeeping and reporting requirements under 40CFR 75, and the requirements of 6NYCRR Part 244-2.1(a)(1). (2) The CAIR designated representative shall submit quarterly reports of the NOx mass emissions data and heat input data for each CAIR NOx unit in an electronic quarterly report in a format prescribed by the Administrator, for each calendar quarter beginning with the calendar quarter corresponding to the earlier of the date of provisional certification or the applicable deadline for initial certification under 6NYCRR Part 244-8.1(b), unless that quarter is the third or fourth quarter of 2007, in which case reporting shall commence in the quarter covering January 1, 2008 through March 31, 2008. (3) The CAIR designated representative shall submit each quarterly report to the Administrator within 30 days following the end of the calendar quarter covered by the report. Quarterly reports shall be submitted in the manner specified in 40CFR 75.73(f). (4) For CAIR NOx units that are also subject to an Acid Rain emissions limitation or the CAIR NOx Ozone Season Trading Program, CAIRS O2 Trading Program, or the Mercury Reduction Program for Coal-Fired Electric Utility Steam Generating Units (6NYCRR Part 246), quarterly reports shall include the applicable data and information required by Subparts F through I of 40CFR Part 75 as applicable, in addition to the NOx mass emission data, heat input data, and other information required by this Subpart. (5) Compliance certification. The CAIR designated representative shall submit to the Administrator a compliance certification in a format prescribed by the Administrator in support of each quarterly report based on reasonable inquiry of those persons with primary responsibility for ensuring that all of the unit's emissions are correctly and fully monitored. The certification shall state that: (i) the monitoring data submitted were recorded in accordance with the applicable requirements of 6NYCRR Part 244 and 40CFR Part 75, including the quality assurance procedures and specifications; and (ii) for a unit with add-on NOx emission controls and for all hours where NOx data are substituted in accordance with 40CFR 75.34(a)(1), the add-on emission controls were operating within the range of parameters listed in the quality assurance/quality control program under appendix B to 40CFR Part 75 and the substitute data values do not systematically underestimate NOx emissions. (6) Whenever any monitoring system fails to meet the quality assurance and quality control requirements or data validation requirements of 40CFR Part 75, data shall be substituted using the applicable missing data procedure in Subpart D or Subpart H of, or appendix D or appendix E to 40CFR Part 75, [244-8.3(a)] (7) Whenever the owner or operator makes a replacement, modification, or change in any certified continuous emission monitoring system under 6NYCRR Part 244-8.1(a)(1) that may significantly affect the ability of the system to accurately measure or record NOx mass emissions or heat input rate or to meet the quality assurance and quality control requirements of 40CFR 75.21 or appendix B to 40CFR Part 75, the owner or operator shall recertify the monitoring system in accordance with 40CFR 75.20(b). Furthermore, whenever the owner or operator makes a placement, modification, or change to the flue gas handling system or the unit's operation that may significantly change the stack flow or concentration profile, the owner or operator shall recertify each continuous emission monitoring system whose accuracy is potentially affected by the change, in accordance with 40CFR 75.20(b). Examples of changes to a continuous emission monitoring system that require recertification include replacement of the analyzer, complete replacement of an existing continuous emission monitoring system, or change in location or orientation of the sampling probe or site. Any fuel flow meter system, and any excepted NOx monitoring system under appendix E to 40CFR Part 75, under 6NYCRR Part 244-8.1(a)(1) are subject to the recertification requirements in 40CFR 75.20(g)(6), [244-8.2(d)](2)</p>	<p>Continuous Emissions Monitoring (CEM). Quarterly reports were submitted electronically to EPA by the reporting deadline.</p>
45	NYCRR Subpart 245-1	<p>1) As of midnight of March 1, or midnight of the first business day thereafter (if March 1 is not a business day) for a control period, the owners and operators of each Clean Air Interstate Rule (CAIR) SO2 source shall hold in the source's compliance account, a tonnage equivalent in CAIR SO2 allowances available for compliance deductions for the control period (January 1 through December 31) not less than the tons of total sulfur dioxide emissions for the control period from all CAIR SO2 units at the source. A CAIR SO2 allowance shall not be deducted, for compliance with the requirements under paragraph (2) of this section, for a control period in a calendar year before the year for which the CAIR SO2 allowance was allocated. [245-1.2(b)](5), 245-1.6(c)(1), 245-1.2(b)(3)(6), 245-1.6(c)(3) 2) The owners and operators shall hold in their compliance account, CAIR SO2 allowances available for compliance deductions for the control period starting on the later of January 1, 2010 or the deadline for meeting a CAIR SO2 unit's monitor certification requirements under section 245-8.1(b)(1), (2), or (5) and for each control period thereafter, [245-1.6(c)(2)] 3) If a CAIR SO2 source emits sulfur dioxide during any control period in excess of the CAIR SO2 emissions limitation, the owners and operators of the source shall surrender the CAIR SO2 allowances required for deduction under 6NYCRR Part 245-6.5(d)(1) and pay any fine, penalty, or assessment or comply with any other remedy imposed for the same violations, under the Act or applicable State law. Each ton of such excess emissions and each day of such control period shall constitute a separate violation of this Subpart, the Act, and applicable State law. [245-1.6(d)] 4) Unless otherwise provided, the owners and operators of the CAIR SO2 source shall keep on site at the source each of the following documents for a period of five years from the date the document is created. This period may be extended for cause, at any time before the end of five years, in writing by the department or the Administrator. [245-1.6(e)] (i) The certificate of representation under 6NYCRR Part 245-2.4 for the CAIR designated representative for the source and all documents that demonstrate the truth of the statements in the certificate of representation, provided that the certificate and documents shall be retained on site at the source beyond such five-year period until such documents are superseded because of the submission of a new certificate of representation under 6NYCRR Part 245-2.4 changing the CAIR designated representative. (ii) All emissions monitoring information, in accordance with 6NYCRR Part 245-8, provided that to the extent that 6NYCRR Part 245-8 provides for a three-year period for recordkeeping, the three-year period shall apply. (iii) Copies of all reports, compliance certifications, and other submissions and all records made or required under the CAIR SO2 Trading Program. (iv) Copies of all documents used to complete a CAIR permit application and any other submission under the CAIR SO2 Trading Program or to demonstrate compliance with the requirements of the CAIR SO2 Trading Program.</p>	<p>March 1st is the deadline for CAIR SO2 allowances to be held for the control period.</p>
46	6NYCRR Subpart 245-2	<p>1) Each CAIR SO2 source shall have one and only one CAIR designated representative and may have one alternate representative, as per 6NYCRR Part 245-2.2, with regard to all matters under the CAIR SO2 Trading Program. The CAIR designated representative of the CAIR SO2 source shall be selected by an agreement binding on the owners and operators of the source and all CAIR SO2 units at the source and shall act in accordance with the certification statement in 6NYCRR Part 245-2.4(a)(4)(iv). Upon receipt by the Administrator of a complete certificate of representation under 6NYCRR Part 245-2.4, the CAIR designated representative of the source shall represent and, by his or her representations, actions, in actions, or submissions, legally bind each owner and operator of the CAIR SO2 source represented and each CAIR SO2 unit at the source in all matters pertaining to the CAIR SO2 Trading Program, notwithstanding any agreement between the CAIR designated representative and such owners and operators. The owners and operators shall be bound by any decision or order issued to the CAIR designated representative by the department, the Administrator, or a court regarding the source or unit. [245-2.1(a), (b) & (c)] (2) Each submission under the CAIR SO2 Trading Program shall be submitted, signed, and certified by the CAIR designated representative for each CAIR SO2 source on behalf of which the submission is made. Each such submission shall include the following certification statement by the CAIR designated representative: "I am authorized to make this submission on behalf of the owners and operators of the source or units for which the submission is made. I certify under penalty of law that I have personally examined, and am familiar with, the statements and information submitted in this document and all its attachments. Based on my inquiry of those individual with primary responsibility for obtaining the information, I certify that the statements and information are to the best of my knowledge and belief true, accurate, and complete. I am aware that there are significant penalties for submitting false statements and information or omitting required statements and information, including the possibility of fine or imprisonment." [245-2.1(e)]</p>	<p>The CAIR SO2 designated representative will comply with 245-2 and will submit the applicable documents as required.</p>

Condition Number	Applicable Requirement	Description of Requirement	Methods Used to Determine Compliance
47	NYCRR Subpart 245-8	Regulated Contaminant(s): CAS No. 007 446-09-5 SULFUR DIOXIDE 1) The owners and operators, the Clean Air Interstate Rule (CAIR) designated representative, of a CAIR SO2 unit, shall comply with the monitoring recordkeeping, and reporting requirements as provided in Subpart 6 NYCRR Part 245-8 and in 40 CFR Part 75, Subparts F and G. For purposes of complying with such requirements, the definitions shall apply, and the terms "affected unit," "designated representative," and "continuous emission monitoring system" (or "CEMS") in 40 CFR Part 75 shall be deemed to refer to the terms "CAIR SO2 unit," "CAIR designated representative," and "continuous emission monitoring system" (or "CEMS") respectively, as defined in section 245-1.2. The owner or operator of a unit that is not a CAIR SO2 unit but that is monitored under 40 CFR 75.16(b)(2) shall comply with the same monitoring recordkeeping and reporting requirements as a CAIR SO2 unit. [245-8.1.2] The owner or operator of each CAIR SO2 unit shall: [245-8.1(a)] (i) install all monitoring systems required under this Subpart for monitoring SO2 mass emissions and individual unit heat input (including all systems required to monitor SO2 concentration, stack gas moisture content, stack gas flow rate, CO2 or O2 concentration, and fuel flow rate, as applicable, in accordance with 40 CFR 75.11 and 40 CFR 75.16); (ii) successfully complete all certification tests required under Part 245-8.2 and meet all other requirements of this section and 40 CFR Part 75 applicable to the monitoring systems under this section; (iii) record, report, and quality-assure the data from the monitoring systems under paragraph (i) of this section. 3) The owner or operator shall meet the monitoring system certification and other requirements of section 245-8.1(a)(1) and (2) on or before the following dates. The owner or operator shall record, report, and quality-assure the data from the monitoring systems under section 245-8.1(a)(1) on and after the following dates: [245-8.1(b)] (i) For the CAIR SO2 unit that commences commercial operation before July 1, 2008, by January 1, 2009. (ii) For the CAIR SO2 unit that commences commercial operation on or after July 1, 2008, by the later of the following dates: January 1, 2009; or 90 unit operating days or 180 calendar days, whichever occurs first, after the date on which the unit commences commercial operation. 4) Whenever the owner or operator makes a replacement, modification, or change in any certified continuous emission monitoring system under section 245-8.1(a)(1) that may significantly affect the ability of the system to accurately measure or record SO2 mass emissions or heat input rate or to meet the quality-assurance and quality-control requirements of 40 CFR 75.21 or appendix B to 40 CFR Part 75, the owner or operator shall recertify the monitoring system in accordance with 40 CFR 75.20(b). Furthermore, whenever the owner or operator makes a replacement, modification, or change to the flue gas handling system or the unit's operation that may significantly change the stack flow or concentration profile, the owner or operator shall recertify each continuous emission monitoring system whose accuracy is potentially affected by the change, in accordance with 40 CFR 75.20(b). Examples of changes to a continuous emission monitoring system that require recertification include: replacement of the analyzer, complete replacement of an existing continuous emission monitoring system, or change in location or orientation of the sampling probe or site. Any fuel flow meter system under section 245-8.1(a)(1) is subject to the recertification requirements in 40 CFR 75.20(g)(6). [245-8.2(d)(2)] 5) Whenever any monitoring system fails to meet the quality-assurance and quality-control requirements or data validation requirements of 40 CFR Part 75, data shall be substituted using the applicable missing data procedures in Subpart D of or appendix D to 40 CFR Part 75. [245-8.3(a)] 6) The CAIR designated representative shall comply with all recordkeeping and reporting requirements in section 245-8.3, the applicable recordkeeping and reporting requirements in Subparts F and G of 40 CFR Part 75, and the requirements of section 245-2.1(e)(1). [245-8.5(a)] 7) The owner or operator of a CAIR SO2 unit shall comply with requirements of 40 CFR 75.62 for monitoring plans. [245-8.5(b)]	Continuous Emissions Monitoring (CEM). Quarterly reports were submitted electronically to EPA by the reporting deadline.
48	40 CFR 60.4, NSPS Subpart A	All requests, reports, applications, submittals, and other communications to the Administrator pursuant to this part shall be submitted in duplicate to the following address: Director, Division of Enforcement and Compliance Assistance USEPA Region 2 290 Broadway, 21st Floor New York, NY 10007-1886 Copies of all correspondence to the administrator pursuant to this part shall also be submitted to the NYSDEC Regional Office issuing this permit (see address at the beginning of this permit) and to the following address: NYSDEC Bureau of Quality Assurance 625 Broadway Albany, NY 12233-3258	Applicable notifications and reports have been and will be made in the future in accordance with this condition.
49	40 CFR 60.7(a), NSPS Subpart A	Any owner or operator subject to this part shall furnish the Administrator with the following information: 1) a notification of the date construction or reconstruction commenced, post marked no later than 30 days after such date; 3) a notification of the actual date of initial start up, post marked within 15 days after such date; 4) a notification of any physical or operational change to an existing facility which may increase the emission rate of any air pollutant to which a standard applies, unless the change is specifically exempted under this part. The notice shall be post marked 60 days or as soon as practicable before the change is commenced and shall include information describing the precise nature of the change, present and proposed emission control systems, productive capability of the facility before and after the change, and the expected completion date of the change. Administrator may request additional information regarding the change; 5) a notification of the date upon which the demonstration of continuous monitoring system performance commences, post marked not less than 30 days prior to such date; 6) a notification of the anticipated date for conducting the opacity observations, post marked not less than 30 days prior to such date.	Construction date notifications will be furnished to the Administrator as required in Part 40 CFR 60.7(a) and NSPS Subpart A.
50	40 CFR 60.7(b), NSPS Subpart A	Affected owners or operators shall maintain records of occurrence and duration of any startup, shutdown, or malfunction in the operation of an affected facility, any malfunction of the air pollution control equipment, or any periods during which a continuous monitoring system or monitoring device is inoperative.	Emissions are monitored and recorded by a certified CEMS following all applicable QA/QC requirements. Reports are filed in accordance with 201-1.4 time frames during periods of noncompliance as a result of startup, shutdown, and equipment malfunction.
51	40 CFR 60.7(f), NSPS Subpart A	The following files shall be maintained at the facility for all affected sources: all measurements, including continuous monitoring systems, monitoring device, and performance testing measurements; all continuous monitoring system performance evaluations; all continuous monitoring device calibration checks; adjustments and maintenance performed on these systems or devices; and all other information required by this part, recorded in permanent form suitable for inspections. The file shall be maintained for at least two years following the date of such measurements, reports, and records.	The Facility files will be maintained on site for two years following the date.
52	40 CFR 60.8(a), NSPS Subpart A	Within 60 days after achieving the maximum production rate, but not later than 180 days after initial startup of the facility, the owner or operator of the facility shall conduct performance testing and provide the results of such tests, in a written report to the Administrator.	Performance testing will begin within 60 days of reaching maximum production rate, but not later than 180 days after initial startup.
53	40 CFR 60.8(b), NSPS Subpart A	Performance testing shall be conducted in accordance with the methods and procedures prescribed in 40 CFR 60 or by alternative methods and procedures approved by the Administrator.	Performance testing will be conducted as per 40 CFR 60.
54	40 CFR 60.8(d), NSPS Subpart A	The owner or operator shall provide the Administrator with prior notice of any performance test at least 30 days in advance of testing.	30 days prior notice will be given for performance testing.
55	40 CFR 60.8(e), NSPS Subpart A	The following performance testing facilities shall be provided during all tests: 1) sampling ports adequate for tests; methods applicable to such facility; 2) a safe sampling platform; 3) a safe access to the sampling platform; and 4) utilities for sampling and testing equipment.	Safe Conditions and adequate ports and utilities will be present during performance testing.
56	40 CFR 60.8(f), NSPS Subpart A	Each performance test shall consist of three separate runs, at the specified duration required in the applicable test method. Compliance with all applicable standards shall be determined by using the arithmetic means of the results of the three runs.	Performance test will have three runs at the specified duration.
57	40 CFR 60, NSPS Subpart III	Facilities that have stationary compression ignition internal combustion engines must comply with applicable portions of 40 CFR 60 Subpart III.	Facility will comply.
58	40 CFR 60.4335, NSPS Subpart KKKK	As an alternative to continuously monitoring the water or steam to fuel ratio the facility shall install, certify, maintain, and operate a continuous emission monitoring system (CEMS) consisting of a NOx monitor and a diluent gas (oxygen or carbon dioxide) monitor, to determine hourly NOx emissions in parts per million (ppm).	Record Keeping / Maintenance Procedures. NOx emissions are continuously monitored in the CEMS.
59	40 CFR 60.4375(a), NSPS Subpart KKKK	For each affected unit required to continuously monitor parameters or emissions, or to periodically determine the fuel sulfur content, reports of excess emissions and monitor downtime shall be submitted in accordance with 40 CFR 60.7(c). Excess emissions must be reported for all periods of unit operation, including start-up, shutdown, and malfunction.	Record Keeping / Maintenance Procedures. The fuel sulfur content is monitored periodically in accordance with 40 CFR 75, Appendix D. Excess emissions were submitted by the reporting deadline.
60	40 CFR Part 2	This facility is subject to the Title IV Acid Rain Regulations found in 40 CFR Parts 72.7, 73, 76, 77 and 78. The Acid Rain Permit is an attachment to this permit.	The facility will abide by the Acid Rain Permit.
61	6 NYCRR 227-1.3(a)	No owner or operator of a combustion installation shall operate the installation in such a way to emit greater than 20 percent opacity except for one six minute period per hour, not to exceed 27 percent, based upon the six minute average in reference test Method 9 in Appendix A of 40 CFR 60.	Monitoring of Process or Control Device Parameter as Surrogate Observations for visible emissions were performed while operating and recorded.

Condition Number	Applicable Requirement	Description of Requirement	Methods Used to Determine Compliance
62	6NYCRR 227-1.3(a)	No person shall operate a stationary combustion installation which exhibits greater than 20 percent opacity (six minute average), except for one six-minute period per hour of not more than 27 percent opacity. The Department reserves the right to perform or require the performance of a Method 9 opacity evaluation at any time during facility operation. The permittee will conduct observations of visible emissions from the emission unit, process, etc. to which this condition applies at the monitoring frequency stated below while the process is in operation. The permittee will investigate, in a timely manner, any instance where there is cause to believe that visible emissions have the potential to exceed the opacity standard. The permittee shall investigate the cause, make any necessary corrections, and verify that the excess visible emissions problem has been corrected. If visible emissions with the potential to exceed the standard continue, the permittee will conduct a Method 9 assessment with in the next operating day of the sources associated with the potential noncompliance to determine the degree of opacity and will notify the NYSDCE (the method 9 test indicates that the opacity standard is not met. Records of visible emissions observations (or any follow-up method 9 tests), investigations and corrective actions will be kept on-site. Should the Department determine that permittee's record keeping format is inadequate to demonstrate compliance with this condition, it shall provide written notice to the permittee stating the inadequacies, and permittee shall have 90 days to revise its prospective record keeping format in a manner acceptable to the Department.	Method 9 visual observations are conducted during testing on the unit..
63	40CFR 60.43c(a), NSPS Subpart DC	On and after the date on which the initial performance test is completed or required to be completed under §60.8, whichever date comes first, no owner or operator of an affected facility shall cause to be discharged into the atmosphere from that affected facility any gases that exhibit greater than 20 percent opacity (6-minute average), except for one 6-minute period per hour of not more than 27 percent opacity. The facility shall perform a method 9 evaluation.	Method 9 visual observations are conducted during testing on the unit..
64	40CFR 60.48c(a), NSPS Subpart DC	The owner and operator of each affected facility shall submit notification of the date of construction or reconstruction, anticipated startup, and actual startup, as provided by 40CFR 60.7 of this part. This notification shall include: (1) The design heat input capacity of the affected facility and identification of fuels to be combusted in the affected facility. (2) If applicable, a copy of any Federally enforceable requirement that limits the annual capacity factor for any fuel or mixture of fuels under 40CFR 60.42c, or 40CFR 60.43c. (3) The annual capacity factor at which the owner or operator anticipates operating the affected facility based on all fuels fired and based on each individual fuel fired.	Anticipated: Date of construction, anticipated startup, design heat, annual fuel usage has been submitted as required 40CFR 60.48c(a), NSPS Subpart DC
65	6NYCRR 231-5.4	Emission Unit: U-00003 Process: P3B Regulated Contaminant(s): CAS No: 0NY998-00-0 CAS No: 0NY210-00-0 VOC OXIDES OF NITROGEN Operation of the Auxiliary boiler is restricted to 2000 hours per year. Facility will maintain usage records and fuel consumption.	Aux. Boiler is restricted to <2,000 hours per year, usage records maintained at the facility.
66	6NYCRR 231-5.4	Emission Unit: U-00003 Process: P3B Regulated Contaminant(s): CAS No: 0NY998-00-0 VOC LAER is 0.008 lb/mmBtu. Will be achieved using good combustion controls. Emission testing to be performed within 180 days of startup.	Emissions testing to be performed within 180 days of startup.
67	6NYCRR 231-5.4	Emission Unit: U-00003 Process: P3B Regulated Contaminant(s): CAS No: 0NY210-00-0 OXIDES OF NITROGEN LAER is 0.0450 lb/mmBtu. Will be achieved using low NOx burners and flue gas recirculation. Emission testing to be performed within 180 days of startup.	Emissions testing to be performed within 180 days of startup.
68	6NYCRR 231-7.6	Emission Unit: U-00003 Process: P3B Regulated Contaminant(s): CAS No: 0NY075-00-0 PARTICULATES CAS No: 0NY075-00-5 PM-10 BACT is 0.0063 lb/mmBtu. Will be achieved using low sulfur fuel. Emission testing to be performed within 180 days of startup.	Emissions testing to be performed within 180 days of startup.
69	6NYCRR 231-7.6	Emission Unit: U-00003 Process: P3B Regulated Contaminant(s): CAS No: 007446-09-5 SULFUR DIOXIDE BACT is 0.0022 lb/mmBtu. Will be achieved using low sulfur fuel. Emission testing to be performed within 180 days of startup.	Emissions testing to be performed within 180 days of startup.
70	6NYCRR 231-7.6	Emission Unit: U-00003 Process: P3B Regulated Contaminant(s): CAS No: 007664-98-9 SULFURIC ACID BACT is 0.0002 lb/mmBtu. Will be achieved using low sulfur fuel. Emission testing to be performed within 180 days of startup.	Emissions testing to be performed within 180 days of startup.
71	6NYCRR 231-7.6	Emission Unit: U-00003 Process: P3B Regulated Contaminant(s): CAS No: 000630-08-0 CARBON MONOXIDE BACT is 0.0721 lb/mmBtu. Will be achieved using good combustion controls. Emission testing to be performed within 180 days of startup.	Emissions testing to be performed within 180 days of startup.
72	40CFR 60.48c(a)(2), NSPS Subpart DC	Emission Unit: U-00003 Process: P3B Emission Source: AUX01 As an alternative to meeting the requirements of 40 CFR 60.48c(g)(1), the owner or operator of an affected facility that combusts only natural gas, wood, fuels using fuel certification in 40 CFR 60.48c(f) to demonstrate compliance with the SO ₂ Standard, fuels not subject to an emissions standard (excluding opacity), or a mixture of these fuels may elect to record and maintain records of the amount of each fuel combusted during each calendar month.	Fuel shall be tracked.
73	6NYCRR 231-5.4	Emission Unit: U-00004 Process: P04 Regulated Contaminant(s): CAS No: 0NY998-00-0 VOC LAER is 0.0391 lb/mmBtu. Will be achieved using good combustion controls. Emission testing to be performed upon request of the Department.	Emissions testing to be performed upon request of the Department.
74	6NYCRR 231-5.4	Emission Unit: U-00004 Process: P04 Regulated Contaminant(s): CAS No: 0NY210-00-0 OXIDES OF NITROGEN LAER is 4.77 grams per brake horsepower-hour. Will be achieved using good combustion controls. Emission testing to be performed upon request of the Department.	Emissions testing to be performed upon request of the Department.
75	6NYCRR 231-7.6	Emission Unit: U-00004 Process: P04 Regulated Contaminant(s): CAS No: 0NY075-00-0 PARTICULATES CAS No: 0NY075-00-5 PM-10 BACT is 0.03 ghp-hr. Will be achieved using low sulfur fuel. Emission testing to be performed at the request of the Department.	Emissions testing to be performed upon request of the Department.
76	6NYCRR 231-7.6	Emission Unit: U-00004 Process: P04 Regulated Contaminant(s): CAS No: 007446-09-5 SULFUR DIOXIDE BACT is 0.0014 lb/mmBtu. Will be achieved using low sulfur fuel. Emission testing to be performed at the request of the Department.	Emissions testing to be performed upon request of the Department.
77	6NYCRR 231-7.6	Emission Unit: U-00004 Process: P04 Regulated Contaminant(s): CAS No: 007664-98-9 SULFURIC ACID BACT is 0.00003 lb/mmBtu. Will be achieved using low sulfur fuel. Emission testing to be performed at the request of the Department.	Emissions testing to be performed upon request of the Department.
78	6NYCRR 231-7.6	Emission Unit: U-00004 Process: P04 Regulated Contaminant(s): CAS No: 000630-08-0 CARBON MONOXIDE BACT is 0.45 ghp-hr. Will be achieved using good combustion controls. Emission testing to be performed at the request of the Department.	Emissions testing to be performed upon request of the Department.
79	6NYCRR 231-5.4	Emission Unit: U-00005 Process: P05 Regulated Contaminant(s): CAS No: 0NY210-00-0 OXIDES OF NITROGEN LAER is 0.857 pounds per million Btus. Will be achieved using good combustion controls. Emission testing to be performed upon request of the Department.	Emissions testing to be performed upon request of the Department.
80	6NYCRR 231-5.4	Emission Unit: U-00005 Process: P05 Regulated Contaminant(s): CAS No: 0NY998-00-0 VOC LAER is 0.3612 lb/mmBtu. Will be achieved using good combustion controls. Emission testing to be performed upon request of the Department.	Emissions testing to be performed upon request of the Department.
81	6NYCRR 231-7.6	Emission Unit: U-00005 Process: P05 Regulated Contaminant(s): CAS No: 000630-08-0 CARBON MONOXIDE BACT is 0.75 lb/mmBtus.. Will be achieved using good combustion controls. Emission testing to be performed at the request of the Department.	Emissions testing to be performed upon request of the Department.
82	6NYCRR 231-7.6	Emission Unit: U-00005 Process: P05 Regulated Contaminant(s): CAS No: 0NY075-00-0 PARTICULATES CAS No: 0NY075-00-5 PM-10 BACT is 0.043 lb/mmBtus.. Will be achieved using low sulfur fuel. Emission testing to be performed at the request of the Department.	Emissions testing to be performed upon request of the Department.
83	6NYCRR 231-7.6	Emission Unit: U-00005 Process: P05 Regulated Contaminant(s): CAS No: 007446-09-5 SULFUR DIOXIDE BACT is 0.0014 lb/mmBtu. Will be achieved using low sulfur fuel. Emission testing to be performed at the request of the Department.	Emissions testing to be performed upon request of the Department.
84	6NYCRR 231-7.6	Emission Unit: U-00005 Process: P05 Regulated Contaminant(s): CAS No: 007664-98-9 SULFURIC ACID BACT is 0.00003 lb/mmBtu. Will be achieved using low sulfur fuel. Emission testing to be performed at the request of the Department.	Emissions testing to be performed upon request of the Department.
85	6NYCRR 231-5.4	Emission Unit: U-00006 Process: P06 Regulated Contaminant(s): CAS No: 0NY210-00-0 OXIDES OF NITROGEN LAER is 0.058 pounds per million Btus for each individual gas heater. Will be achieved using forced draft low NOx Burner. Emission testing to be performed upon request of the Department.	Emissions testing to be performed upon request of the Department.
86	6NYCRR 231-5.4	Emission Unit: U-00006 Process: P06 Regulated Contaminant(s): CAS No: 0NY998-00-0 VOC LAER is 0.011 lb/mmBtu. Will be achieved using good combustion controls. Emission testing to be performed upon request of the Department.	Emissions testing to be performed upon request of the Department.
87	6NYCRR 231-7.6	Emission Unit: U-00006 Process: P06 Regulated Contaminant(s): CAS No: 007664-98-9 SULFURIC ACID BACT is 0.0002 lb/mmBtu. Will be achieved using low sulfur fuel. Emission testing to be performed at the request of the Department.	Emissions testing to be performed upon request of the Department.

Condition Number	Applicable Requirement	Description of Requirement	Methods Used to Determine Compliance
88	6NYCRR 231-7.6	Emission Unit: U-00006 Process: P06 Regulated Contaminant(s): CAS No:00060-08-0 CARBON MONOXIDE BACT is 0.084 lb/mmmBtu. Will be achieved using good combustion controls. Emission testing to be performed at the request of the Department.	Emissions testing to be performed upon request of the Department.
89	6NYCRR 231-7.6	Emission Unit: U-00006 Process: P06 Regulated Contaminant(s): CAS No:00075-00-0 PARTICULATES CAS No:00075-00-5 PM-10 BACT is 0.0076lb/mmmBtu. Will be achieved using low sulfur fuel. Emission testing to be performed at the request of the Department.	Emissions testing to be performed upon request of the Department.
90	6NYCRR 231-7.6	Emission Unit: U-00006 Process: P06 Regulated Contaminant(s): CAS No:007446-09-5 SULFUR DIOXIDE BACT is 0.0022lb/mmmBtu. Will be achieved using low sulfur fuel. Emission testing to be performed at the request of the Department.	Emissions testing to be performed upon request of the Department.
91	ECL 19-0301	Emissions of the following contaminants are subject to contaminant specific requirements in this permit. CAS No:000124-38-9 Name: CARBON DIOXIDE CAS No:00060-08-0 Name: CARBON MONOXIDE CAS No:007446-09-5 Name: SULFUR DIOXIDE CAS No:007664-41-7 Name: AMMONIA CAS No:007664-95-9 Name: SULFURIC ACID CAS No:00075-00-0 Name: PARTICULATES CAS No:00075-00-5 Name: PM-10 CAS No:00075-02-5 Name: PM 2.5 CAS No:000210-00-0 Name: OXIDES OF NITROGEN CAS No:00095-00-0 Name: VOC	Emissions are subject to contaminant specific requirements.
92	6NYCRR 201-1.4	The facility owner and/or operator shall compile and maintain records of all equipment maintenance or start-up/shutdown activities when they can be expected to result in an exceedance of any applicable emission standard, and shall submit a report of such activities to the commissioner's representative when requested to do so in writing or when so required by a permit issued for the corresponding air contamination source except where conditions elsewhere in this permit which contain more stringent reporting and notification provisions for an applicable requirement, in which case they supercede those stated here. Such reports shall describe why the violation was unavoidable and shall include the time, frequency and duration of the maintenance and/or start-up/shutdown activities and the identification of air (b) In the event that emissions of air contaminants in excess of any emission standard in 6NYCRR Chapter III Subchapter A occur due to a malfunction, the facility owner and/or operator shall report such malfunction by telephone to the commissioner's representative as soon as possible during normal working hours, but in any event not later than two working days after becoming aware that the malfunction occurred. Within 30 days thereafter, when requested in writing by the commissioner's representative, the facility owner and/or operator shall submit a written report to the commissioner's representative describing the malfunction, the corrective action taken, identification of air contaminants, and an estimate of the emission rates. These reporting requirements are superceded by conditions elsewhere in this permit which contain reporting and notification provisions for applicable requirements more stringent than those above. (c) The Department may also require the owner and/or operator to include in reports described under (a) and (b) above an estimate of the maximum ground level concentration of each air contaminant emitted and the effect of such emissions depending on the deviation of the malfunction and the air contaminants emitted. In the event of maintenance, start-up/shutdown or malfunction conditions which result in emissions exceeding any applicable emission standard, the facility owner and/or operator shall take appropriate action to prevent emissions which will result in contravention of any applicable ambient air quality standard. Reasonably available control technology, as determined by the commissioner, shall be applied during any maintenance, start-up/shutdown or malfunction condition subject to this paragraph. (d) (e) In order to have a violation of a federal regulation (such as a new source performance standard or national emissions standard for hazardous air pollutants) excused, the specific federal regulation must provide for an affirmative defense during start-up, shutdowns, malfunctions or upsets.	Facility shall maintain records of operation and report any deviations.
93	6NYCRR Subpart 201-5	The facility is authorized to perform regulated processes under this permit for: ONE F CLASS COMBUSTION TURBINE RATED AT 1998 MMBTU/HR AT 51 DEGREES F (2234 MMBTU/HR AT -5 DEGREES F) ON NATURAL GAS AND 2145 MMBTU/HR AT -5 DEGREES F ON FUEL OIL (0.0015% SULFUR). THE TURBINE IS EQUIPPED WITH DRY LOW-NOX COMBUSTORS, STEAM INJECTION, SCR AND OXIDATION CATALYST EMISSION CONTROLS. THIS EMISSION UNIT ALSO CONTAINS A NATURAL GAS-FIRED DUCT BURNER RATED AT A MAXIMUM CAPACITY OF 500 MMBTU/HR. ACC01 GEN01 HRS G01	This is an accurate description of the emission unit.
93 (continued)	6NYCRR Subpart 201-5	The facility is authorized to perform regulated processes under this permit for: ONE CLASS-F COMBUSTION TURBINE RATED AT 1998 MMBTU/HR AT 51 DEGREES F (2234 MMBTU/HR AT -5 DEGREES F) ON NATURAL GAS AND 2145 MMBTU/HR AT -5 DEGREES F ON FUEL OIL (0.0015% SULFUR). THE TURBINE IS EQUIPPED WITH DRY LOW-NOX COMBUSTORS, STEAM INJECTION, SCR AND OXIDATION CATALYST EMISSION CONTROLS. THIS EMISSION UNIT ALSO CONTAINS A NATURAL GAS-FIRED DUCT BURNER RATED AT A MAXIMUM CAPACITY OF 500 MMBTU/HR. Building(s): ACC02 GEN02 HRS G02	This is an accurate description of the emission unit.
93 (continued)	6NYCRR Subpart 201-5	The facility is authorized to perform regulated processes under this permit for: EMISION UNIT: U-00003 Emission Unit Description: ONE 73.5 MMBTU/HR AUXILIARY BOILER THAT WILL FIRE NATURAL GAS EXCLUSIVELY. THE BOILER HOURS WILL BE LIMITED TO 2000 HOURS PER YEAR. THE BOILER WILL OPERATE PRIMARILY TO ASSIST WITH STARTUPS AND SHUTDOWNS OF THE TURBINES. Building(s): GEN01	This is an accurate description of the emission unit.
93 (continued)	6NYCRR Subpart 201-5	The facility is authorized to perform regulated processes under this permit for: Emission Unit: U-00004 Emission Unit Description: Emergency Diesel Generator operating less than 500 hours per year.	This is an accurate description of the emission unit.
93 (continued)	6NYCRR Subpart 201-5	The facility is authorized to perform regulated processes under this permit for: Emission Unit: U-00005 Emission Unit Description: Emergency Fire water Pump	This is an accurate description of the emission unit.
93 (continued)	6NYCRR Subpart 201-5	The facility is authorized to perform regulated processes under this permit for: Emission Unit: U-00006 Emission Unit Description: Two Fuel Gas Heaters	This is an accurate description of the emission unit.
94	6NYCRR 211.2	Except as permitted by a specific part of this Subchapter and for open fires for which a restricted burning permit has been issued, no person shall cause or allow any air contamination source to emit any material having an opacity equal to or greater than 20 percent (six minute average) except for one continuous six-minute period per hour of not more than 57 percent opacity.	Method 9 visual observations are conducted.
95	6NYCRR 242-1.5	The owners and operators of a CO2 budget source that has excess emissions in any control period shall: (1) forfeit the CO2 allowances required for deduction under 6 NYCRR Part 242-6.5(d)(1), provided CO2 offset allowances may not be used to cover any part of such excess emissions; and (2) pay any fine, penalty, or assessment or comply with any other remedy imposed under 6 NYCRR Part 242-6.5(d)(2).	The facility shall comply.
96	6NYCRR 242-1.5	The owners and operators and, to the extent applicable, the CO2 authorized account representative of each CO2 budget source and each CO2 budget unit at the source shall comply with the monitoring requirements of Subpart 242-8. The emissions measurements recorded and reported in accordance with Subpart 242-8 of this Part shall be used to determine compliance by the unit with the following CO2 requirements: (1) The owners and operators of each CO2 budget source and each CO2 budget unit at the source shall hold CO2 allowances available for compliance deductions under Section 242-6.5, as of the CO2 allowance transfer deadline, in the source's compliance account in an amount not less than the total CO2 emissions for the control period from all CO2 budget units at the source, as determined in accordance with Subparts 242-6 and 242-8; (2) Each ton of CO2 emitted in excess of the CO2 budget emissions limitation shall constitute a separate violation of this Part and applicable state law. (3) A CO2 budget unit shall be subject to the requirements specified in item 1 starting on the later of January 1, 2009 or the date on which the unit commences operation. (4) CO2 allowances shall be held in, deducted from, or transferred among CO2 Allowance Tracking System accounts in accordance with Subparts 242-5, 242-6, and 242-7, and Section 242-10.7. (5) A CO2 allowance shall not be deducted in order to comply with the requirements specified in item 1 for a control period that ends prior to the allocation year for which the CO2 allowance was allocated. A CO2 offset allowance shall not be deducted, in order to comply with the requirements under item 1, beyond the applicable percent limitations set out in 6NYCRR Part 242-6.5(a)(3). (6) A CO2 allowance under the CO2 Budget Trading Program is a limited authorization by the Department or a participating state to emit one ton of CO2 in accordance with the CO2 Budget Trading Program. No provision of the CO2 Budget Trading Program, the CO2 budget permit application, or the CO2 budget permit or any provision of law shall be construed to limit the authority of the Department or a participating state to terminate or limit such authorization. (7) A CO2 allowance under the CO2 Budget Trading Program does not constitute a property right.	Record Keeping/Maintenance Procedures. CO2 emissions are continuously calculated in the CEMS using 40 CFR 75 Appendix D and G

Condition Number	Applicable Requirement	Description of Requirement	Methods Used to Determine Compliance
97	6NYCRR 242-1.5	The owners and operators of the CO2 budget source and each CO2 budget unit at the source shall keep on site at the source each of the following documents for a period of 10 years from the date the document is created. This period may be extended for cause, at any time prior to the end of 10 years, in writing by the department. (i) The account certificate of representation for the CO2 authorized account representative for the source and each CO2 budget unit at the source and all documents that demonstrate the truth of the statements in the account certificate of representation, in accordance with 6NYCRR Part 242-2.4, provided that the certificate and documents shall be retained on site at the source beyond such 10-year period until such documents are superseded because of the submission of a new account certificate of representation. (ii) All emissions monitoring information, in accordance with Subpart 242-8 and 40CFR 75.57. (iii) Copies of all reports, compliance certifications, and other submissions and all records made or required under the CO2 Budget Trading Program. (iv) Copies of all documents used to complete a CO2 budget permit application and any other submission under the CO2 Budget Trading Program or to demonstrate compliance with the requirements of the CO2 Budget Trading Program. The CO2 authorized account representative of a CO2 budget source and each CO2 budget unit at the source shall submit the reports and compliance certifications required under the CO2 Budget Trading Program, including those under Subpart 242-4.	Record Keeping/Maintenance Procedures. CO2 emissions are continuously calculated in the CEMS using 40 CFR 75 Appendices D and G
98	6NYCRR Subpart 201-5	The following emissions points are included in this permit for the cited Emission Unit: Emission Unit: U-00001 Emission Point: EP001 Hight(ft.):275 Diameter(in.):228 NYTMN(km.):4584.693 NYTME(km.):546.98 Emission Unit: U-00002 Emission Point: EP002 Hight(ft.):275 NYTMN(km.):4584.655 NYTME(km.):546.991 Diameter(in.):228 Emission Unit: U-00003 Emission Point: EP003 Hight(ft.): 275 NYTMN(km.):4584.655 NYTME(km.):546.991 Diameter(in.):228 Emission Unit: U-00004 Emission Point: EP004 Hight(ft.):50 NYTMN(km.):4584.651 NYTME(km.):547.129 Diameter(in.):18 Emission Unit: U-00005 Emission Point: EP006 Hight(ft.):50 NYTMN(km.):4584.669 NYTME(km.):546.815 Diameter(in.):8 Emission Unit: U-00006 Emission Point: EP005 Hight(ft.): 125 NYTMN(km.):4584.58 NYTME(km.):546.958 Diameter(in.):24	This is an accurate description of the emission unit.
99	6NYCRR Subpart 201-5	Emissions Unit: U-00001 Process: P1A REPRESENTS NATURAL GAS FIRING IN THE CLASS-F COMBUSTION TURBINE, WHICH IS RATED AT 2,234 mmBTU/hr AT -5 DEGREES F (MAXIMUM HEAT INPUT SCENARIO). DRY LOW-NOX COMBUSTION TECHNOLOGY, SELECTIVE CATALYTIC REDUCTION (SCR) AND OXIDATION CATALYST WILL BE USED TO MINIMIZE EMISSIONS OF NOX, CO, AND VOC. THE QUANTITY PER HOUR THROUGH PUT LISTED BELOW REPRESENTS THE SOURCE CLASSIFICATION CODE: 2-01-002-01 MAXIMUM FIRING RATE (2,234 MMBtu/hr AT -5 DEGREES F) AND THE QUANTITY PER YEAR THROUGH PUT REPRESENTS THE TURBINE AT THE FIRING RATE AT THE ANNUAL AVERAGE AMBIENT TEMPERATURE OF 51 DEGREES F (1,998 MMBtu/hr). NATURAL GAS HIGHER HEATING VALUE IS ASSUMED TO BE 1,048 BTU/CUBIC FOOT. Emission Source/Control: CT001 - Combustion Design Capacity: 2,234 million Btu per hour Emission Source/Control: DLN01 - Control Control Type: DRY LOW NOX BURNER Emission Source/Control: OXY01 - Control Control Type: CATALYTIC OXIDATION Emission Source/Control: SCR01 - Control Control Type: SELECTIVE CATALYTIC REDUCTION (SCR)	This is an accurate description of the emission unit.
99 (continued)	6NYCRR Subpart 201-5	Emissions Unit: U-00001 Process: P2A REPRESENTS COMBINED NATURAL GAS FIRING IN THE CLASS-F COMBUSTION TURBINE, WHICH IS RATED AT 2,234 mmBTU/hr AT -5 DEGREES F (MAXIMUM HEAT INPUT SCENARIO) AND NATURAL GAS FIRING IN THE DUCT BURNER, WHICH IS RATED AT 500 mmBTU/hr. DRY LOW-NOX COMBUSTION TECHNOLOGY, SELECTIVE CATALYTIC REDUCTION (SCR) AND OXIDATION CATALYST WILL BE USED TO MINIMIZE EMISSIONS OF NOX, CO, AND VOC. THE QUANTITY PER HOUR THROUGH PUT LISTED BELOW REPRESENTS THE MAXIMUM FIRING RATE (2,234 MMBtu/hr AT -5 DEGREES F) OF THE TURBINE PLUS THE DUCT BURNER AT RATED CAPACITY (500 mmBTU/hr) AND THE QUANTITY PER YEAR THROUGH PUT REPRESENTS 8,760 HOURS OF NATURAL GAS FIRING IN THE TURBINE AT THE ANNUAL AVERAGE AMBIENT TEMPERATURE OF 51 DEGREES F (1,998 MMBtu/hr). NATURAL GAS HIGHER HEATING VALUE IS ASSUMED TO BE 1,048 BTU/CUBIC FOOT. Emission Source/Control: CT001 - Combustion Design Capacity: 2,234 million Btu per hour Emission Source/Control: DB001 - Combustion Design Capacity: 500 million Btu per hour Emission Source/Control: DLN01 - Control Control Type: DRY LOW NOX BURNER Emission Source/Control: OXY01 - Control Control Type: CATALYTIC OXIDATION Emission Source/Control: SCR01 - Control Control Type: SELECTIVE CATALYTIC REDUCTION (SCR)	This is an accurate description of the emission unit.
99 (continued)	6NYCRR Subpart 201-5	Emissions Unit: U-00001 Process: P3A REPRESENTS FUEL OIL FIRING IN THE CLASS-F COMBUSTION TURBINE, WHICH IS RATED AT 2,145 mmBTU/hr AT -5 DEGREES F (MAXIMUM HEAT INPUT SCENARIO). DRY LOW-NOX COMBUSTION TECHNOLOGY, STEAM OR WATER INJECTION, SELECTIVE CATALYTIC REDUCTION (SCR) AND OXIDATION CATALYST WILL BE USED TO MINIMIZE EMISSIONS OF NOX, CO, AND VOC. THE QUANTITY PER HOUR THROUGH PUT LISTED BELOW REPRESENTS THE MAXIMUM FIRING RATE (2,145 MMBtu/hr AT -5 DEGREES F) AND THE QUANTITY PER YEAR THROUGH PUT REPRESENTS 720 HOURS OF FUEL OIL FIRING AT THE FIRING RATE AT -5 DEGREES F AMBIENT TEMPERATURE. FUEL OIL HIGHER HEATING VALUE IS ASSUMED TO BE 139,728 BTU/GALLON. Source Classification Code: 2-01-001-01 Emission Source/Control: CT001 - Combustion Design Capacity: 2,234 million Btu per hour Emission Source/Control: DLN01 - Control Control Type: DRY LOW NOX BURNER Emission Source/Control: OXY01 - Control Control Type: CATALYTIC OXIDATION Emission Source/Control: SCR01 - Control Control Type: SELECTIVE CATALYTIC REDUCTION (SCR) Emission Source/Control: ST101 - Control Control Type: STEAM OR WATER INJECTION	This is an accurate description of the emission unit.
99 (continued)	6NYCRR Subpart 201-5	Emissions Unit: U-00002 Process: P01 REPRESENTS NATURAL GAS FIRING IN THE CLASS-F COMBUSTION TURBINE, WHICH IS RATED AT 2,234 mmBTU/hr AT -5 DEGREES F (MAXIMUM HEAT INPUT SCENARIO). DRY LOW-NOX COMBUSTION TECHNOLOGY, SELECTIVE CATALYTIC REDUCTION (SCR) AND OXIDATION CATALYST WILL BE USED TO MINIMIZE EMISSIONS OF NOX, CO, AND VOC. THE QUANTITY PER HOUR THROUGH PUT LISTED BELOW REPRESENTS THE SOURCE CLASSIFICATION CODE: 2-01-002-01 MAXIMUM FIRING RATE (2,234 MMBtu/hr AT -5 DEGREES F) AND THE QUANTITY PER YEAR THROUGH PUT REPRESENTS THE TURBINE AT THE FIRING RATE AT THE ANNUAL AVERAGE AMBIENT TEMPERATURE OF 51 DEGREES F (1,998 MMBtu/hr). NATURAL GAS HIGHER HEATING VALUE IS ASSUMED TO BE 1,048 BTU/CUBIC FOOT. Emission Source/Control: CT002 - Combustion Design Capacity: 2,234 million Btu per hour Emission Source/Control: DLN02 - Control Control Type: DRY LOW NOX BURNER Emission Source/Control: OXY02 - Control Control Type: CATALYTIC OXIDATION Emission Source/Control: SCR02 - Control Control Type: SELECTIVE CATALYTIC REDUCTION (SCR)	This is an accurate description of the emission unit.
99 (continued)	6NYCRR Subpart 201-5	Emissions Unit: U-00002 Process: P02 Emission Unit: U-00002 Process: P02 Process Description: REPRESENTS COMBINED NATURAL GAS FIRING IN THE CLASS-F COMBUSTION TURBINE, WHICH IS RATED AT 2,234 mmBTU/hr AT -5 DEGREES F (MAXIMUM HEAT INPUT SCENARIO) AND NATURAL GAS FIRING IN THE DUCT BURNER, WHICH IS RATED AT 500 mmBTU/hr. DRY LOW-NOX COMBUSTION TECHNOLOGY, SELECTIVE CATALYTIC REDUCTION (SCR) AND OXIDATION CATALYST WILL BE USED TO MINIMIZE EMISSIONS OF NOX, CO, AND VOC. THE QUANTITY PER HOUR THROUGH PUT LISTED BELOW REPRESENTS THE MAXIMUM FIRING RATE (2,234 MMBtu/hr AT -5 DEGREES F) OF THE TURBINE PLUS THE DUCT BURNER AT RATED CAPACITY (500 mmBTU/hr) AND THE QUANTITY PER YEAR THROUGH PUT REPRESENTS 8,760 HOURS OF NATURAL GAS FIRING IN THE TURBINE AT THE ANNUAL AVERAGE AMBIENT TEMPERATURE OF 51 DEGREES F (1,998 MMBtu/hr). NATURAL GAS HIGHER HEATING VALUE IS ASSUMED TO BE 1,048 BTU/CUBIC FOOT. Emission Source/Control: CT002 - Combustion Design Capacity: 2,234 million Btu per hour Emission Source/Control: DB002 - Combustion Design Capacity: 500 million Btu per hour Emission Source/Control: DLN02 - Control Control Type: DRY LOW NOX BURNER Emission Source/Control: OXY02 - Control Control Type: CATALYTIC OXIDATION Emission Source/Control: SCR02 - Control Control Type: SELECTIVE CATALYTIC REDUCTION (SCR)	This is an accurate description of the emission unit.



CPV Valley Energy Center
50 Braintree Hill Office Park
Suite 300
Braintree, MA 02184

ATTACHMENT 7

Exempt Activities



DEC ID											
3	-	3	3	5	6	-	0	0	1	3	6

List of Exempt Activities

Instructions

Applicants for Title V facility permits must provide a listing of each exempt activity, as described in 6 NYCRR Part 201-3.2(c), that is currently operated at the facility. This form provides a means to fulfill this requirement.

In order to complete this form, enter the number and building location of each exempt activity. Building IDs used on this form should match those used in the Title V permit application. If a listed activity is not operated at the facility, leave the corresponding information blank.

Combustion

Rule Citation 201-3.2(c)	Description	Number of Activities	Building Location
(1)	Stationary or portable combustion installations where the furnace has a maximum heat input capacity less than 10 mmBtu/hr burning fuels other than coal or wood; or a maximum heat input capacity of less than 1 mmBtu/hr burning coal or wood. This activity does not include combustion installations burning any material classified as solid waste, as defined in 6 NYCRR Part 360, or waste oil, as defined in 6 NYCRR Subpart 225-2.	7	Turbine Bldg, Outdoor
(2)	Space heaters burning waste oil at automotive service facilities, as defined in 6 NYCRR Subpart 225-2, generated on-site or at a facility under common control, alone or in conjunction with used oil generated by a do-it-yourself oil changer as defined in 6 NYCRR Subpart 374-2.		
(3)(i)	Stationary or portable internal combustion engines that are liquid or gaseous fuel powered and located within the New York City metropolitan area or the Orange County towns of Blooming Grove, Chester, Highlands, Monroe, Tuxedo, Warwick, or Woodbury, and have a maximum mechanical power rating of less than 200 brake horsepower.		
(3)(ii)	Stationary or portable internal combustion engines that are liquid or gaseous fuel powered and located outside of the New York City metropolitan area or the Orange County towns of Blooming Grove, Chester, Highlands, Monroe, Tuxedo, Warwick, or Woodbury, and have a maximum mechanical power rating of less than 400 brake horsepower.	1	FPB01
(3)(iii)	Stationary or portable internal combustion engines that are gasoline powered and have a maximum mechanical power rating of less than 50 brake horsepower.		
(4)	Reserved.		
(5)	Gas turbines with a heat input at peak load less then 10 mmBtu/hour		

New York State Department of Environmental Conservation
Air Permit Application



Department of Environmental Conservation

DEC ID											
3	-	3	3	5	6	-	0	0	1	3	6

Rule Citation	Description	Number of Activities	Building Location
201-3.2(c)			
(6)	Emergency power generating stationary internal combustion engines, as defined in 6 NYCRR Part 200.1(cq), and engine test cells at engine manufacturing facilities that are utilized for research and development, reliability performance testing, or quality assurance performance testing. Stationary internal combustion engines used for peak shaving and/or demand response programs are not exempt.	1	3B
Combustion Related			
(7)	Non-contact water cooling towers and water treatment systems for process cooling water and other water containers designed to cool, store or otherwise handle water that has not been in direct contact with gaseous or liquid process streams.		
Agricultural			
(8)	Feed and grain milling, cleaning, conveying, drying and storage operations including grain storage silos, where such silos exhaust to an appropriate emissions control device, excluding grain terminal elevators with permanent storage capacities over 2.5 million U.S. bushels, and grain storage elevators with capacities above one million bushels.		
(9)	Equipment used exclusively to slaughter animals, but not including other equipment at slaughterhouses, such as rendering cookers, boilers, heating plants, incinerators, and electrical power generating equipment.		
Commercial - Food Service Industries			
(10)	Flour silos at bakeries, provided all such silos are exhausted through an appropriate emission control device.		
(11)	Emissions from flavorings added to a food product where such flavors are manually added to the product.		
Commercial - Graphic Arts			
(12)	Screen printing inks/coatings or adhesives which are applied by a hand-held squeegee. A hand-held squeegee is one that is not propelled though the use of mechanical conveyance and is not an integral part of the screen printing process.		
(13)	Graphic arts processes at facilities located outside the New York City metropolitan area or the Orange County towns of Blooming Grove, Chester, Highlands, Monroe, Tuxedo, Warwick, or Woodbury whose facility-wide total emissions of volatile organic compounds from inks, coatings, adhesives, fountain solutions and cleaning solutions are less than three tons during any 12-month period.		

New York State Department of Environmental Conservation
Air Permit Application



Department of
Environmental
Conservation

DEC ID											
3	-	3	3	5	6	-	0	0	1	3	6

Rule Citation	Description	Number of Activities	Building Location
201-3.2(c)			
(14)	Graphic label and/or box labeling operations where the inks are applied by stamping or rolling.		
(15)	Graphic arts processes which are specifically exempted from regulation under 6 NYCRR Part 234, with respect to emissions of volatile organic compounds which are not given an A rating as described in 6 NYCRR Part 212.		
Commercial - Other			
(16)	Gasoline dispensing sites registered with the department pursuant to 6 NYCRR Part 612.		
(17)	Surface coating and related activities at facilities which use less than 25 gallons per month of total coating materials, or with actual volatile organic compound emissions of 1,000 pounds or less from coating materials in any 12-month period. Coating materials include all paints and paint components, other materials mixed with paints prior to application, and cleaning solvents, combined. This exemption is subject to the following: (i) The facility is located outside of the New York City metropolitan area or the Orange County towns of Blooming Grove, Chester, Highlands, Monroe, Tuxedo, Warwick, or Woodbury; and (ii) All abrasive cleaning and surface coating operations are performed in an enclosed building where such operations are exhausted into appropriate emission control devices.		
(18)	Abrasive cleaning operations which exhaust to an appropriate emission control device.		
(19)	Ultraviolet curing operations.		
Municipal/Public Health Related			
(20)	Landfill gas ventilating systems at landfills with design capacities less than 2.5 million megagrams (3.3 million tons) and 2.5 million cubic meters (2.75 million cubic yards), where the systems are vented directly to the atmosphere, and the ventilating system has been required by, and is operating under, the conditions of a valid 6 NYCRR Part 360 permit, or order on consent.		
Storage Vessels			
(21)	Distillate fuel oil, residual fuel oil, and liquid asphalt storage tanks with storage capacities below 300,000 barrels.	3	Outside

New York State Department of Environmental Conservation
Air Permit Application



Department of Environmental Conservation

DEC ID											
3	-	3	3	5	6	-	0	0	1	3	6

Rule Citation	Description	Number of Activities	Building Location
201-3.2(c)			
(22)	Pressurized fixed roof tanks which are capable of maintaining a working pressure at all times to prevent emissions of volatile organic compounds to the outdoor atmosphere.		
(23)	External floating roof tanks which are of welded construction and are equipped with a metallic-type shoe primary seal and a secondary seal from the top of the shoe seal to the tank wall.		
(24)	External floating roof tanks which are used for the storage of a petroleum or volatile organic liquid with a true vapor pressure less than 4.0 psi (27.6 kPa), are of welded construction and are equipped with one of the following: (i) a metallic-type shoe seal; (ii) a liquid-mounted foam seal; (iii) a liquid-mounted liquid-filled type seal; or (iv) equivalent control equipment or device.		
(25)	Storage tanks, including petroleum liquid storage tanks as defined in 6 NYCRR Part 229, with capacities less than 10,000 gallons, except those subject to 6 NYCRR Part 229 or Part 233.		
(26)	Horizontal petroleum or volatile organic liquid storage tanks.		
(27)	Storage silos storing solid materials, provided all such silos are exhausted through an appropriate emission control device. This exemption does not include raw material, clinker, or finished product storage silos at Portland cement plants.		
Industrial			
(28)	Processing equipment at existing sand and gravel and stone crushing plants which were installed or constructed before August 31, 1983, where water is used for operations such as wet conveying, separating, and washing. This exemption does not include processing equipment at existing sand and gravel and stone crushing plants where water is used for dust suppression.		
(29)(i)	Sand and gravel processing or crushed stone processing lines at a non-metallic mineral processing facility that are a permanent or fixed installation with a maximum rated processing capacity of 25 tons of minerals per hour or less.		

New York State Department of Environmental Conservation
Air Permit Application



Department of Environmental Conservation

DEC ID											
3	-	3	3	5	6	-	0	0	1	3	6

Rule Citation	Description	Number of Activities	Building Location
201-3.2(c)			
(29)(ii)	Sand and gravel processing or crushed stone processing lines at a non-metallic mineral processing facility that are a portable emission source with a maximum rated processing capacity of 150 tons of minerals per hour or less.		
(29)(iii)	Sand and gravel processing or crushed stone processing lines at a non-metallic mineral processing facility that are used exclusively to screen minerals at a facility where no crushing or grinding takes place.		
(30)	Reserved.		
(31)	Surface coating operations which are specifically exempted from regulation under 6 NYCRR Part 228, with respect to emissions of volatile organic compounds which are not given an A rating pursuant to 6 NYCRR Part 212.		
(32)	Pharmaceutical tablet branding operations.		
(33)	Thermal packaging operations, including, but not limited to, thermage labeling, blister packing, shrink wrapping, shrink banding, and carton gluing.		
(34)	Powder coating operations.		
(35)	All tumblers used for the cleaning and/or deburring of metal products without abrasive blasting.		
(36)	Presses used exclusively for molding or extruding plastics except where halogenated carbon compounds or hydrocarbon solvents are used as foaming agents.		
(37)	Concrete batch plants where the cement weigh hopper and all bulk storage silos are exhausted through fabric filters, and the batch drop point is controlled by a shroud or other emission control device.		
(38)	Cement storage operations not located at Portland cement plants where materials are transported by screw or bucket conveyors.		
(39)(i)	Cold cleaning degreasers with an open surface area of 11 square feet or less and an internal volume of 93 gallons or less or, having an organic solvent loss of 3 gallons per day or less.		
39(ii)	Cold cleaning degreasers that use a solvent with a VOC content of five percent or less by weight, unless subject to the requirements of 40 CFR 63 Subpart T.		



DEC ID											
3	-	3	3	5	6	-	0	0	1	3	6

Rule Citation	Description	Number of Activities	Building Location
201-3.2(c)			
(39)(iii)	Conveyorized degreasers with an air/vapor interface smaller than 22 square feet (2 square meters), unless subject to the requirements of 40 CFR 63 Subpart T.		
(39)(iv)	Open-top vapor degreasers with an open-top area smaller than 11 square feet (1 square meter), unless subject to the requirements of 40 CFR 63 Subpart T.		
Miscellaneous			
(40)	Ventilating and exhaust systems for laboratory operations. Laboratory operations do not include processes having a primary purpose to produce commercial quantities of materials.		
(41)	Exhaust or ventilating systems for the melting of gold, silver, platinum and other precious metals.		
(42)	Exhaust systems for paint mixing, transfer, filling or sampling and/or paint storage rooms or cabinets, provided the paints stored within these locations are stored in closed containers when not in use.		
(43)	Exhaust systems for solvent transfer, filling or sampling, and/or solvent storage rooms provided the solvent stored within these locations are stored in containers when not in use.		
(44)	Research and development activities, including both stand-alone and activities within a major facility, until such time as the administrator completes a rule making to determine how the permitting program should be structured for these activities.		
(45)	The application of odor counteractants and/or neutralizers.		
(46)	Hydrogen fuel cells.		
(47)	Dry cleaning equipment that uses only water-based cleaning processes or those using liquid carbon dioxide.		
(48)	Manure spreading, handling and storage at farms and agricultural facilities.		

CPV Valley Energy Center
 Exempt Sources

CPV Valley Energy Center Exempt Sources	Make	Model	Capacity
Fire Pump	Commins	CFPE1E20	NA
Emergency Diesel Generator	Bohler Power System	15V200-GS/N163-5A37	NA
Two (2) Dow Plant Heaters	Mitsui	QVE/PA/LE 45 Gas Burner	NA
Five (5) Space Heaters	Esda	DISE 500	NA
Mobile Generator	Aggreko	HR20	NA
Oil Oil Tank	NA	NA	930,000 Gallons
Emergency Diesel Generator Tank	NA	NA	600 Gallons
Emergency Diesel Fire Pump Tank	NA	NA	500 Gallons



CPV Valley Energy Center
50 Braintree Hill Office Park
Suite 300
Braintree, MA 02184

ATTACHMENT 8

Fire Pump Manufacturer's Information



Engine Specification Sheet
 Cummins Fire Power
 De Pere, WI 54115
<http://www.cumminsfirepower.com>

Basic Engine Model
 CFP9E-F10, **F20**, F30, F40, F50, F60
 Curve Number: FR - 91518 / 91996
 Revision Date: June 2014

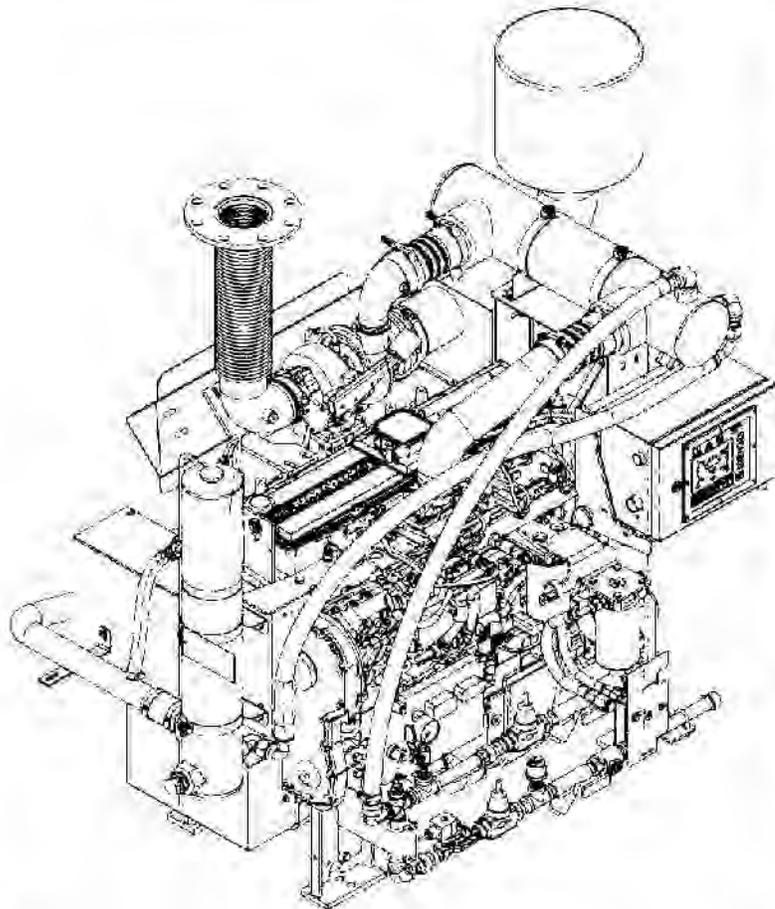

Equipment	Standard	Optional
Air Cleaner	Disposable, Treated for High Humidity, Indoor Service	Washable, 2 Stage Wet Media Elements
Alternator	12V-DC, 95 AMPS; With Belt Guard	24V-DC, 48 AMPS; With Belt Guard
Cooling Loop (Maximum Pressure of 350 PSI)	3/4" diameter for Fresh Water. With alarm sensors and FM Approval.	Optional 1/2" diameter for availability for sea water applications
Exhaust Protection	Metal Guards on Manifolds and Turbo	N/A
Exhaust Flex Connection	SS Flex, NPT	SS Flex, 180°F and up
Flywheel Power Take-Off	Standard	*Drive Shaft System *Bolt System
Fuel Connections	Fire Resistant Flexible Supply and Return Lines	N/A
Fuel Injection System	Electronic, Direct Injection High Pressure Common Rail	N/A
Fuel Filter	Primary and Secondary	N/A
Engine Heater	120V-AC, 2250 Watts	240V-AC, 2250 Watts
Governor, Speed	Constant Speed	N/A
Heat Exchanger	Tube & Shell Type, 60 PSI with NPTF Connections	N/A
Instrument Panel	Digital, NEMA 4X, English and Metric, Tachometer, Hourmeter, Water Temperature, Oil Pressure & Two (2) Voltmeters	Optional 316SS Construction Custom Panels with explosion proofing
Junction Box	Integral with Instrument Panel, For DC Wiring to Engine Controller	N/A
Lube Oil Cooler	Engine Water Cooled, Plate Type	N/A
Lube Oil Filter	Full Flow with By-Pass Valve	N/A
Lube Oil Pump	Gear Driven	N/A
Manual Start	On Instrument Panel	N/A
Overspeed Controls	Electronic with Reset & Test on Instrument Panel	N/A
Raw Water Solenoid Operation	Automatic from Engine Controller & from Emergency Local Control	N/A
Run-Stop Control	On Instrument Panel	N/A
Run Solenoid	12V-DC	24V-DC
Starters	12V-DC	24V-DC
Throttle Control	Adjustable Speed Control	N/A
Water Pump	Belt Drive with Guard	N/A

Operating Speed (RPM)					
Model	1470	1760	1900	2100	2300
CFP9E-F60	304 (227)	359 (268)	365 (272)	355 (265)	304 (227)
CFP9E-F50	289 (216)	350 (261)	360 (268)	332 (248)	285 (213)
CFP9E-F40	271 (202)	327 (244)	347 (259)	311 (232)	267 (199)
CFP9E-F30	248 (185)	305 (227)	323 (241)	289 (216)	248 (185)
CFP9E-F20	230 (172)	282 (210)	299 (223)	268 (200)	230 (172)
CFP9E-F10	215 (160)	260 (194)	275 (205)	246 (183)	212 (158)

Ratings are: HP (kW)

Specifications

Aspiration.....Turbocharged and Charge Air Cooled
 Rotation.....Counterclockwise from flywheel end
 Weight - lb (kg) Est.....1900 (855)
 Displacement - in³ (liter).....543 (8.9)
 Engine Type.....4 Cycle; In-Line, 6 Cylinder
 Engine Series.....Cummins QSL9 Series
 Exhaust Emissions.....EPA/CARB Tier 3



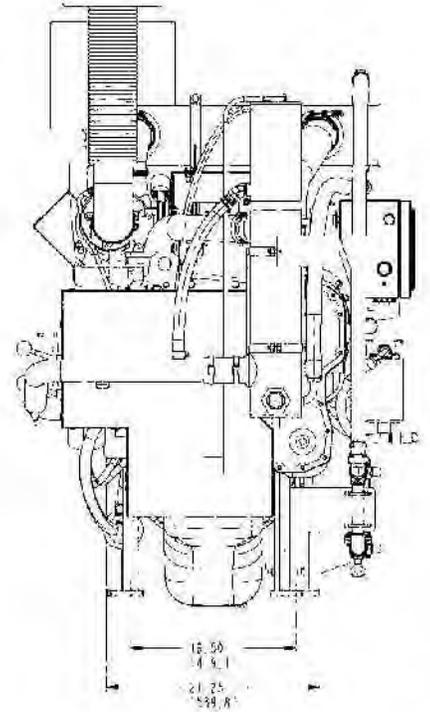
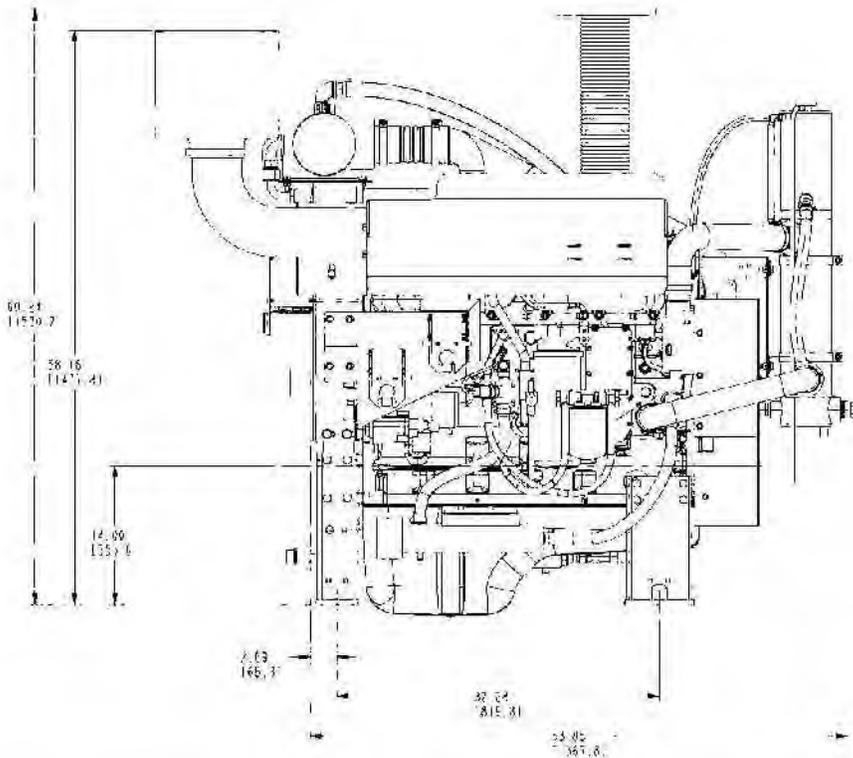

Engine Ratings Baselines

- Engines are rated at standard SAE conditions of 29.61 in. (7521 mm) Hg barometer and 77°F (25°C) inlet air temperature (approximates 300ft. (91.4 m) above sea level) by the testing laboratory (see SAE Standard J1349).
- A deduction of 3 percent from engine horsepower rating at standard SAE conditions shall be made for diesel engines for each 1000 ft. (305 m) altitude above 300 ft. (91.4 m).
- A deduction of 1 percent from engine horsepower rating as corrected to standard SAE conditions shall be made for diesel engines for every 10°F above 77°F (24°C) ambient temperature.

Certified Power

This Cummins Fire Power fire pump driver is built to comply with NFPA-20, and is UL listed and FM approved.

* Subject to change without notification

For additional information, click the hyperlinks below.

www.cumminsfirepower.com



Fire Power

Engine Performance Curve

Cummins Fire Power
De Pere, WI 54115
<http://www.cumminsfirepower.com>

Basic Engine Model
CFP9E-F20

Curve Number: **FR - 91518**
Revision Date: **June 2014**

Engine Family: **Industrial**
Displacement - in.3 (litre): **543 (8.9)**
Compression Ratio: **17.8:1**
No. of Cylinders: **6**
Fuel System: **CCR**

CPL Code: **8641**
Emission Certification: **EPA/CARB Tier 3**
Aspiration: **Turbocharged, Chrg Air Cooled**
Engine Configuration: **D563004CX03**
Minimum rating: **230 HP @ 2300 RPM**
Maximum rating: **299 HP @ 1900 RPM**

Torque Output

RPM	lb-ft	N-m
1470	832	1129
1760	842	1141
1900	826	1121
2100	670	909
2300	525	712

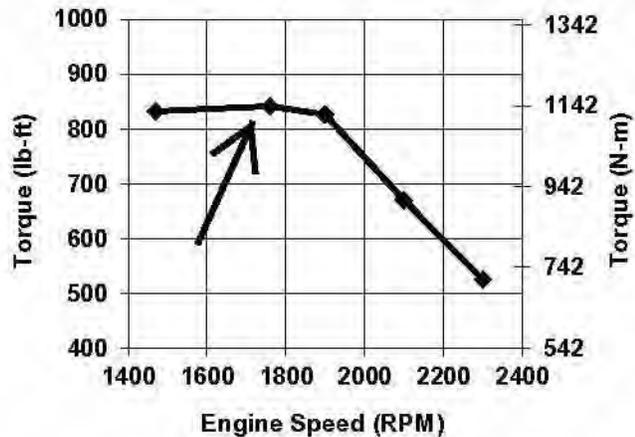

Horsepower Output

RPM	BHP	kW
1470	233	174
1760	282	210
1900	299	223
2100	268	200
2300	230	172

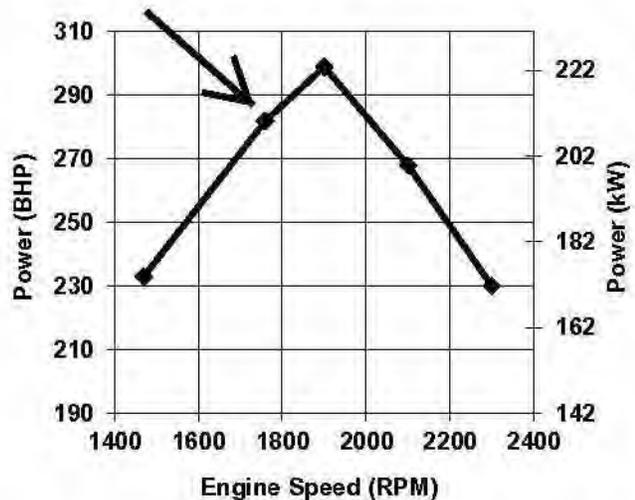

1. Curves shown above represent mature gross engine performance capabilities obtained and corrected in accordance with SAE J1349 conditions of 29.61 in Hg (100 kPa) barometric pressure [300 ft. (91.4 m) altitude], 77 °F (25 °C) inlet air temperature, and 0.30 in. Hg (1 kPa) water vapor pressure with No. 2 diesel fuel.

2. The engine may be operated without changing the fuel setting up to 300 ft. (91.4 m) altitude and up to 77 °F (25 °C) ambient temperature. For sustained operation at high altitudes, the fuel rate of the engine should be adjusted to limit performance by 3% per 1,000 ft. (305 m) above 300 ft. (91.4 m) altitude. For sustained operation at high ambient temperatures, the fuel rate of the engine should be adjusted to limit performance by 1% per 10 °F above 77 °F (2% per 11 °C above 25 °C).

Mike Dawson
Engineering Manager

Certified Within 5%



**Fire
Power**

Engine Data Sheet

Cummins Fire Power
De Pere, WI 54115
<http://www.cumminsfirepower.com>

Basic Engine Model
CFP9E-F10,F20,F30,F40,F50,F60

Curve Number: **FR - 91518**

CPL Code: **8641**

Configuration Number: **D563004CX03**

Installation Drawing: **26112**

Engine Family: **Industrial**

Revision Date: **March 2015**

General Engine Data

Type.....	4 Cycle; In-Line; 6 Cylinder
Aspiration.....	Turbocharged, Chrg Air Cooled
Bore & Stroke - in. (mm).....	4.49 x 5.69 (114 x 145)
Displacement - in. ³ (litre).....	543 (8.9)
Compression Ratio.....	17.8:1
Valves per Cylinder - Intake.....	2
- Exhaust.....	2
Maximum Allowable Bending Moment @ Rear Face of Block - lb.-ft. (N-m).....	1000 (1356)

Air Induction System

Max. Temperature Rise Between Ambient Air and Engine Air Inlet - delta °F (delta °C).....	30 (16.7)
Maximum Inlet Restriction with Dirty Filter - in. H ₂ O (mm H ₂ O).....	25 (635)
Recommended Air Cleaner Element - (Standard).....	FLG Industrial..... AH19220
- (Optional) Heavy Duty Element.....	Primary AF1828 Secondary AF1894M

Lubrication System

Oil Pressure Range at Rated - PSI (kPa)	40-60 (276-414)
Oil Capacity of Pan (High - Low) - U.S. quarts (litre)	24-20
Total System Capacity - U.S. Gal. (litre)	6.5 (24.6)
Recommended Lube Oil Filter	Fleetguard (Cummins)..... LF9009 (3401544)

Cooling System

Raw Water Working Pressure Range at Heat Exchanger - PSI (kPa)	60 (413) MAX
Recommended Min. Water Supply Pipe Size to Heat Exchanger - in. (mm).....	0.75 (19.05)
Recommended Min. Water Disch. Pipe Size From Heat Exchanger - in. (mm).....	1.00 (25.40)
Coolant Water Capacity (Engine Side) - U.S. gal. (litre)	2.9 (11.0)
Standard Thermostat - Type.....	Modulating
- Range - deg F (deg C)	180-199 (82-93)

Minimum Raw Water Flow

with Water Temperatures to 60 °F (16 °C) - U.S. GPM (litre/s)	28.5 (1.80)
with Water Temperatures to 80 °F (27 °C) - U.S. GPM (litre/s)	30.3 (1.91)
with Water Temperatures to 100 °F (38 °C) - U.S. GPM (litre/s)	32 (2.02)
Recommended Cooling Water Filter.....	Fleetguard (Cummins) WF2074 (3100307)

A jacket water heater is mandatory on this engine. The recommended heater wattage is 2250 down to 40 °F (4 °C).

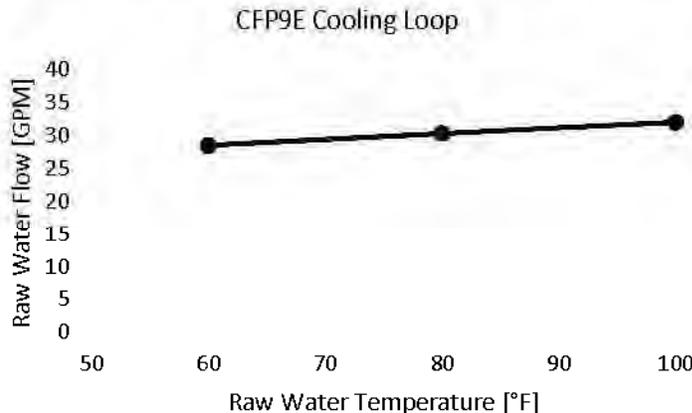

Exhaust System

Max. Back Pressure Imposed by Complete Exhaust System inches H ₂ O (kPa)	40.8	(10.2)
Exhaust Pipe Size Normally Acceptable - in. (mm)	5.0	(127)

Noise Emissions

Top.....	97.2 dBa
Right Side.....	97.2 dBa
Left Side.....	97.2 dBa
Front.....	97.2 dBa
Exhaust.....	119.5 dBa

The noise emission values are estimated sound pressure levels at 3.3 ft. (1 m.).

Fuel Supply / Drain System

Fuel Consumption

	<u>1470</u>	<u>1760</u>	<u>1900</u>	<u>2100</u>	<u>2300</u>
CFP9E-F60 Gal/hr (L/hr)	15.7 (59.5)	18.6 (70.2)	18.9 (71.6)	18.6 (70.4)	16.3 (61.6)
CFP9E-F50 Gal/hr (L/hr)	14.9 (56.5)	18.1 (68.5)	18.7 (70.6)	17.4 (65.8)	15.3 (57.7)
CFP9E-F40 Gal/hr (L/hr)	14.0 (53.0)	16.9 (64.0)	18.0 (68.1)	16.3 (61.7)	14.3 (54.1)
CFP9E-F30 Gal/hr (L/hr)	13.0 (49.3)	15.8 (59.7)	16.7 (63.4)	15.1 (50.2)	13.3 (50.2)
CFP9E-F20 Gal/hr (L/hr)	12.0 (45.6)	14.6 (55.2)	15.5 (58.7)	14.0 (53.2)	12.3 (46.6)
CFP9E-F10 Gal/hr (L/hr)	11.1 (42.1)	13.4 (50.9)	11.3 (54.0)	12.9 (48.8)	11.3 (43.0)

Fuel Type	Number 2 Diesel Only
Minimum Supply Line Size - in. (mm)	0.5 (12.70)
Minimum Drain Line Size - in. (mm)	0.375 (9.53)
Maximum Fuel Height above C/L Fuel Pump in. (m)	227 (5.7)
Recommended Fuel Filter - Primary	Fleetguard (Cummins)..... FF5580 (3976312)
- Secondary	FS1212
Maximum Restriction @ Lift Pump-Inlet - With Clean Filter - in. Hg (mm Hg)	6.0 (152)
Maximum Restriction @ Lift Pump-Inlet - With Dirty Filter - in. Hg (mm Hg)	10.0 (254)
Maximum Return Line Restriction - Without Check Valves - in. Hg (mm Hg)	20.4 (518)
Minimum Fuel Tank Vent Capability - ft ³ /hr (m ³ /hr)	7 (0.21)
Maximum Fuel Temperature @ Lift Pump Inlet - °F (°C)	160 (71)

Starting and Electrical System

	<u>12V</u>	24V
Min. Recommended Batt. Capacity - Cold Soak at 0°F (-18°C) or Above		
Engine Only - Cold Cranking Amperes - (CCA)	1400	900
Engine Only - Reserve Capacity - Minutes	430	230
Battery Cable Size (Maximum Cable Length Not to Exceed 5 ft. [1.5 m] AWG)	00	00
Maximum Resistance of Starting Circuit - Ohms	0.002	0.002
Typical Cranking Speed - RPM	130	130
Alternator (Standard), Internally Regulated - Ampere	95	45
Wiring for Automatic Starting (Negative Ground)	Standard	
Reference Wiring Diagram	16260	

Performance Data

All data is based on the engine operating with fuel system, water pump, lubricating oil pump, air cleaner, and alternator; not included are compressor, fan, optional equipment, and driven components. Data is based on operation at SAE standard J1394 conditions of 300 ft. (91.4 m) altitude, 29.61 in. (752 mm) Hg dry barometer, and 77 °F (25 °C) intake air temperature, using No.2 diesel or a fuel corresponding to ASTM-D2.

Altitude Above Which Output Should be Limited - ft. (m)	300	(91.4)
Correction Factor per 1000 ft. (305 m) above Altitude Limit	3%	
Temperature Above Which Output Should be Limited - °F (°C)	77	(25)
Correction Factor per 10 °F (11 °C) Above Temperature Limit	1%	(2%)

Exhaust Emissions (EPA Tier T3)

See emissions data available for this rating on the Cummins Fire Power website www.cumminsfirepower.com.

FM Approved and UL Listed Ratings for CFP9E-F10, F20, F30, F40, F50, F60

Engine Speed - RPM	1470	1760	1900	2100	2300
CFP9E-F60 Output - BHP (kW) .	304 (227)	359 (268)	365 (272)	355 (265)	304 (227)
Ventilation Air CFM (litre/sec)	580 (274)	723 (341)	738 (348)	788 (372)	827 (391)
Exhaust Flow - CFM (litre/sec) ..	1615 (762)	2041 (963)	2077 (980)	2133 (1,007)	2090 (986)
Exhaust Temp.- °F (°C)	1074 (579)	1049 (565)	1106 (597)	1077 (581)	991 (533)
Heat Rejection					
To Coolant BTU/min. (kW)	4810 (85)	6517 (115)	6705 (118)	6690 (118)	6155 (108)
To Ambient BTU/min (kW)	1223 (21)	1302 (23)	1350 (24)	1305 (23)	1279 (22)
CFP9E-F50 Output - BHP (kW) .	289 (216)	350 (261)	360 (268)	332 (248)	285 (213)
Ventilation Air CFM (litre/sec)	584 (276)	686 (324)	736 (347)	785 (371)	824 (389)
Exhaust Flow - CFM (litre/sec) ..	1621 (765)	1918 (905)	2053 (969)	2107 (995)	2065 (975)
Exhaust Temp.- °F (°C)	1076 (580)	1083 (584)	1097 (592)	1064 (573)	979 (526)
Heat Rejection					
To Coolant BTU/min. (kW)	4849 (85)	6157 (108)	6815 (120)	6530 (115)	6008 (106)
To Ambient BTU/min (kW)	1186 (21)	1263 (22)	1310 (23)	1266 (22)	1241 (22)
CFP9E-F40 Output - BHP (kW) .	271 (202)	327 (244)	347 (259)	311 (232)	267 (199)
Ventilation Air CFM (litre/sec)	557 (263)	685 (323)	735 (347)	783 (370)	822 (388)
Exhaust Flow - CFM (litre/sec) ..	1584 (748)	1899 (896)	2036 (961)	2084 (984)	2042 (964)
Exhaust Temp.- °F (°C)	1083 (584)	1076 (580)	1088 (587)	1052 (567)	1030 (554)
Heat Rejection					
To Coolant BTU/min. (kW)	4885 (86)	5988 (105)	6386 (112)	6417 (113)	5904 (104)
To Ambient BTU/min (kW)	1151 (20)	1225 (22)	1270 (22)	1228 (22)	1203 (21)
CFP9E-F30 Output - BHP (kW) .	252 (188)	305 (227)	323 (241)	289 (216)	248 (185)
Ventilation Air CFM (litre/sec)	558 (263)	681 (321)	727 (343)	781 (369)	820 (387)
Exhaust Flow - CFM (litre/sec) ..	1574 (743)	1863 (879)	1973 (931)	2056 (970)	2015 (951)
Exhaust Temp.- °F (°C)	1075 (579)	1057 (569)	1058 (570)	1037 (558)	954 (512)
Heat Rejection					
To Coolant BTU/min. (kW)	4809 (85)	5807 (102)	6049 (106)	6328 (111)	5822 (102)
To Ambient BTU/min (kW)	1116 (20)	1188 (21)	1232 (22)	1191 (21)	1167 (21)
CFP9E-F20 Output - BHP (kW) .	233 (174)	282 (210)	299 (223)	268 (200)	230 (172)
Ventilation Air CFM (litre/sec)	555 (262)	674 (318)	720 (340)	776 (366)	815 (385)
Exhaust Flow - CFM (litre/sec) ..	1527 (721)	1813 (856)	1927 (910)	2019 (953)	1979 (934)
Exhaust Temp.- °F (°C)	1033 (556)	1030 (554)	1036 (558)	1018 (548)	937 (503)
Heat Rejection					
To Coolant BTU/min. (kW)	4436 (79)	5591 (98)	5880 (103)	6189 (109)	5694 (100)
To Ambient BTU/min (kW)	1083 (19)	1153 (20)	1195 (21)	1155 (20)	1132 (20)
CFP9E-F10 Output - BHP (kW) .	215 (160)	260 (194)	275 (205)	246 (183)	212 (158)
Ventilation Air CFM (litre/sec)	544 (257)	665 (314)	712 (336)	763 (360)	801 (378)
Exhaust Flow - CFM (litre/sec) ..	1432 (676)	1751 (826)	1872 (884)	1922 (907)	1884 (889)
Exhaust Temp.- °F (°C)	971 (522)	997 (536)	1008 (542)	968 (520)	891 (477)
Heat Rejection					
To Coolant BTU/min. (kW)	4259 (75)	5340 (94)	5679 (100)	5781 (102)	5319 (93)
To Ambient BTU/min (kW)	1050 (18)	1118 (20)	1159 (20)	1121 (20)	1098 (19)

All Data is Subject to Change Without Notice.

Engineering Manager: Mike Dawson
Cummins Fire Power, De Pere, WI 54115 U.S.A.



**Fire
Power**

EPA Tier 3 Emission Data
Fire Pump NSPS Compliant

CFP9E-F20 Fire Pump Driver

Type: 4 Cycle; In-Line; 6 Cylinder
Aspiration: Turbocharged, Charge Air Cooled

15 PPM Diesel Fuel																			
RPM	BHP	Fuel Consumption		D2 Cycle Exhaust Emissions										Exhaust					
		Gal/Hr	L/hr	Grams per BHP - HR					Grams per kW - HR					Temperature		Gas Flow			
				NMHC	NOx	NMHC+NOx	CO	PM	NMHC	NOx	NMHC+NOx	CO	PM	°F	°C	CFM	L/sec		
1470	230	11.3	42.8													1033	556	1527	721
1760	282	14.1	53.4													1030	554	1813	856
1900	299	15.0	56.8	0.123	2.200	2.323	1.417	0.118	0.165	2.950	3.116	1.900	0.158		1036	558	1927	910	
2100	268	14.2	53.8												1018	548	2019	953	
2300	230	12.6	47.7												937	503	1979	934	

The emissions values above are based on CARB approved calculations for converting EPA (500 ppm) fuel to CARB (15 ppm) fuel.

300-4000 PPM Diesel Fuel																			
RPM	BHP	Fuel Consumption		D2 Cycle Exhaust Emissions										Exhaust					
		Gal/Hr	L/hr	Grams per BHP - HR					Grams per kW - HR					Temperature		Gas Flow			
				NMHC	NOx	NMHC+NOx	CO	PM	NMHC	NOx	NMHC+NOx	CO	PM	°F	°C	CFM	L/sec		
1470	230	11.3	42.8													1033	556	1527	721
1760	282	14.1	53.4													1030	554	1813	856
1900	299	15	56.8	0.149	2.386	2.535	1.417	0.134	0.2	3.200	3.400	1.900	0.180		1036	558	1927	910	
2100	268	14.2	53.8												1018	548	2019	953	
2300	230	12.6	47.7												937	503	1979	934	

QSL9 Base Model Manufactured by Cummins Inc.
- Using fuel rating 91518

Reference EPA Standard Engine Family: ECEXL0540AAB

No special options needed to meet current regulation emissions for all 50 states

Test Methods:

EPA/CARB Nonroad emissions recorded per 40CFR89 (ref. ISO8178-1) and weighted at load points prescribed in Subpart E, Appendix A, for Constant Speed Engines (ref. ISO8178-4, D2).

Diesel Fuel Specifications:

Cetane Number: 40-48
Reference: ASTM D975 No. 2-D

Reference Conditions:

Air Inlet Temperature: 25°C (77°F)
Fuel Inlet Temperature: 40°C (104°F)
Barometric Pressure: 100 kPa (29.53 in Hg)
Humidity: 10.7 g/kg (75 grains H₂O/lb) of dry air, required for NOx correction
Restrictions: Intake Restriction set to a maximum allowable limit for clean filter, Exhaust Back Pressure set to maximum allowable limit.

Tests conducted using alternate test methods, instrumentation, fuel or reference conditions can yield different results.

Revision:
June 2014: Document Review & Approved



CPV Valley Energy Center
50 Braintree Hill Office Park
Suite 300
Braintree, MA 02184

ATTACHMENT 9

Auxiliary Boiler Manufacturers' Data

BOILER PREDICTED PERFORMANCE*

Version: NB-Size-2014.0.1 Customer: CPV Valley Energy Cent CP-4448 HA 03/08/16
 Proposal: CP-4448 - Design Fuel: Natural Gas
 Model: NB-200D-4C Design Pressure: 250 PSIG

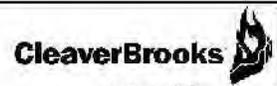

March 8, 2016

Boiler load - %	100%	75%	50%	25%						
Steam Flow - Gross Production	39,050	29,288	19,525	9,763						Lb/Hr
Net Steam Flow - Gross less Pegging Steam	32,550	24,413	16,275	8,138						Lb/Hr
Pegging Steam	6,500	4,875	3,250	1,625						Lb/Hr
Steam Pressure - Operating	115	115	115	115						PSIG
Steam Temperature	347	347	347	347						°F
Fuel Input (HHV)	46.7	34.9	23.3	11.8						MMBTU/Hr
Ambient Air Temperature	80	80	80	80						°F
Relative Humidity	60	60	60	60						%
Excess Air	15	15	15	25						%
Flue Gas Recirculation	9	9	9	9						%
Steam Output Duty	39.0	29.3	19.5	9.8						MMBTU/hr
Heat Release Rate - Volumetric	64,233	47,988	31,972	16,214						BTU/FT3-Hr
Heat Release Rate - Area	96,884	72,382	48,224	24,456						BTU/FT2-Hr
Heat Flux	29,983									BTU/FT2-Hr
Feed Water Temperature	228	228	228	228						°F
Water Temperature Leaving Economizer	303	291	278	267						±10°F
Blow Down	3.0	3.0	3.0	3.0						%
Boiler Gas Exit Temperature	583	518	450	386						±10°F
Economizer Gas Exit Temperature	300	278	259	245						±10°F
Air Flow	39,285	29,350	19,554	10,779						Lb/Hr
Flue Gas to Stack	41,259	30,824	20,537	11,277						Lb/Hr
Flue Gas Including FGR	44,972	33,599	22,385	12,292						Lb/Hr
Fuel Flow	1,973	1,474	982	498						Lb/Hr
Flue Gas Analysis, Losses, Efficiency - %										
Dry Gas Loss	4.1	3.7	3.4	3.4						%
Air Moisture Loss	0.1	0.1	0.1	0.1						%
Fuel Moisture Loss	10.7	10.6	10.5	10.5						%
Casing Loss	0.6	0.8	1.2	2.4						%
Margin	1.0	1.0	1.0	1.0						%
Efficiency - LHV	92.5	92.9	92.9	91.6						%
Efficiency - HHV	83.5	83.8	83.8	82.6						%
Total Pressure Drop Including Economizer	3.52	1.96	0.87	0.24						IN WC
Products of Combustion - CO2	8.26	8.26	8.26	7.65						% vol.
- H2O	18.21	18.21	18.21	17.02						% vol.
- N2	71.06	71.06	71.06	71.53						% vol.
- O2	2.46	2.46	2.46	3.80						% vol.
- SO2	0.00	0.00	0.00	0.00						% vol.
Fuel Composition - Gas										
BOILER SURFACE AREAS-ft2										
methane	97.186 % vol.	Furnace Volume:		727	ft3					
ethane	2.423 % vol.	Furnace Projected Area:		482	ft2					
propane	0.098 % vol.	Evaporator:		2,018	ft2					
butane	0.006 % vol.	Total Area:		2,501	ft2					
hexane	0.01 % vol.	Economizer:		By Supplier	ft2					
carbon dioxide	0.021 % vol.	Superheater:		-	ft2					
nitrogen	0.254 % vol.									
hydrogen sulfide	0.00018 % vol.									
oxygen	0.002 % vol.									
LHV-Btu/lb	21,360									
HHV-Btu/lb	23,684									
*Above data is predicted only, see proposal for guaranteed numbers.										

BOILER PREDICTED PERFORMANCE*

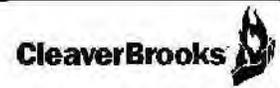

Version: NB-Size-2014.0.1 Customer: CPV Valley Energy Gen CP-4448 HA
 Proposal: CP-4448 - w/ APH Fuel: Natural Gas
 Model: NB-200D-4C Design Pressure: 250

Boiler load - %	100%	75%	50%	25%						
Steam Flow - Gross Production	39,800	29,850	19,900	9,950						Lb/Hr
Net Steam Flow - Gross less Pegging Steam	32,550	24,413	16,275	8,138						Lb/Hr
Pegging Steam	7,250	5,438	3,625	1,813						Lb/Hr
Steam Pressure - Operating	115	115	115	115						PSIG
Steam Temperature	347	347	347	347						°F
Fuel Input (HHV)	48.1	35.9	23.9	12.1						MMBTU/Hr
Ambient Air Temperature	50	50	50	50						°F
Relative Humidity	7	7	7	7						%
Excess Air	15	15	15	25						%
Flue Gas Recirculation	9	9	9	9						%
Steam Output Duty	39.8	29.8	19.9	9.9						MMBTU/hr
Heat Release Rate - Volumetric	66,055	49,351	32,883	16,690						BTU/FT3-H
Heat Release Rate - Area	99,632	74,438	49,598	25,175						BTU/FT2-H
Heat Flux	31,118									BTU/FT2-H
Feed Water Temperature	228	228	228	228						°F
Water Temperature Leaving Economizer	302	290	277	269						±10°F
Blow Down	3.0	3.0	3.0	3.0						%
Boiler Gas Exit Temperature	587	521	452	394						±10°F
Economizer Gas Exit Temperature	301	278	259	246						±10°F
Air Flow	39,894	29,806	19,859	10,957						Lb/Hr
Flue Gas to Stack	41,924	31,322	20,870	11,469						Lb/Hr
Flue Gas Including FGR	45,697	34,141	22,748	12,502						Lb/Hr
Fuel Flow	2,029	1,516	1,010	512						Lb/Hr
Flue Gas Analysis, Losses, Efficiency - %										
Dry Gas Loss	4.7	4.3	3.9	4.0						%
Air Moisture Loss	0.0	0.0	0.0	0.0						%
Fuel Moisture Loss	11.0	10.9	10.8	10.8						%
Casing Loss	0.6	0.8	1.2	2.4						%
Margin	1.0	1.0	1.0	1.0						%
Efficiency - LHV	91.7	92.1	92.1	90.7						%
Efficiency - HHV	82.7	83.0	83.1	81.8						%
Total Pressure Drop Including Economizer	3.59	2.00	0.89	0.27						IN WC
Products of Combustion - CO2	8.42	8.42	8.42	7.80						% vol.
- H2O	16.68	16.68	16.68	15.46						% vol.
-N2	72.39	72.39	72.39	72.88						% vol.
-O2	2.51	2.51	2.51	3.87						% vol.
-SO2	0.00	0.00	0.00	0.00						% vol.
Fuel Composition - Gas										
methane	97.186	% vol.	Furnace Volume:		727	ft3				
ethane	2.423	% vol.	Furnace Projected Area:		482	ft2				
propane	0.098	% vol.	Evaporator:		2,018	ft2				
butane	0.006	% vol.	Total Area:		2,501	ft2				
hexane	0.01	% vol.	Economizer:		By Supplier	ft2				
carbon dioxide	0.021	% vol.	Superheater:		-	ft2				
nitrogen	0.254	% vol.								
hydrogen sulfide	0.00018	% vol.								
oxygen	0.002	% vol.								
LHV-Btu/lb	21,360									
HHV-Btu/lb	23,684									
<i>*Above data is predicted only, see proposal for guaranteed numbers.</i>										



CPV Valley Energy Center
50 Braintree Hill Office Park
Suite 300
Braintree, MA 02184

ATTACHMENT 10

NYSDEC Acceptance Memo Air Modeling

New York State Department of Environmental Conservation
Division of Air Resources
Bureau of Stationary Sources
625 Broadway, Albany, New York 12233-3254
Phone: (518) 402-8403 • **FAX:** (518) 402-9035
Website: www.dec.ny.gov



June 28, 2012

MEMORANDUM

TO: George Sweikert (Region 3)
FROM: Bob Gaza
SUBJECT: CPV Valley Energy Center

We have completed the review of the June 2012 Supplement to the modeling portion of the PSD and Part 201 Air Permit Application and find the modeling analysis acceptable. The applicant has properly followed the procedures outlined in the approved May 2012 "Modeling Protocol Supplement 3" to address the 1-hour impacts of NO₂. Specifically, the applicant has demonstrated that the maximum impacts from CPV Valley do not exceed EPA's interim Significant Impact Level (7.5 µg-m⁻³) at the receptors where a violation of the National Ambient Air Quality Standards (NAAQS) was indicated via cumulative modeling of surrounding sources for 1-hr NO₂. The NAAQS for 1-hr NO₂ is 188 µg-m⁻³. Violations were identified near or on the properties of the Al Ton and Revere facilities in course grid runs for all sources, with maximum impacts, including background, of 419 µg-m⁻³ and 274 µg-m⁻³, respectively. The applicant applied a finer grid mesh of 100 m around the receptors where violations were detected in additional AERMOD runs. In this instance, a maximum impact of 442 µg-m⁻³ was identified. Again, the updated modeling substantiated that CPV Valley did not contribute significantly to any of these violations. The 3 tables depicting the results of these model runs are attached for your information.

cc: M. Valls
C. Hogan
A. Coulter (EPA, Region 2)
M. Anderson (TRC)

Table 5:21: Additional Cumulative 1-Hour Average NO₂ Modeling Results for the Initial (Coarse) Receptor Grid

Closest Facility	Source Contributions to the Highest 8th High Predicted NO ₂ Concentrations (µg/m ³) *			
	Project	Other Sources	Background	Total
CPV Energy	121	0.0708	61.7	183
Al Turi	2.62E-03	346	73.0	419
Revere	2.91E-03	214	59.6	274
SIL *	7.50	--	--	--
NAAQS *	--	--	--	188

* 5-Year Average

Table 5.22: Additional Cumulative 1-Hour Average NO₂ Modeling Results for the Three Refined Receptor Grids

	Source Contributions to the Highest 8th High Predicted NO ₂ Concentration (µg/m ³) *			
	Project	Other Sources	Background	Total
Maximum Total Impact (Warm Startup)	4.16E-03	378	63.9	442
Maximum Project Contribution (Warm Startup)	6.31	148	56.8	211
SIL *	7.50	---	---	---
NAAQS *	---	---	---	188

* 5-Year Average

Table 5.23: Additional Cumulative 1-Hour Average NO₂ Modeling Results for the Receptors Located within Facility Fence Lines

	Source Contributions to the Highest 8th High Predicted NO ₂ Concentration (µg/m ³) *			
	Project	Other Sources	Background	Total
Inside Revere Fence Line	8.17E-03	92.1	67.1	159
Inside Al Turi Fence Line	6.12	5.93	92.7	105
SIL *	7.50	---	---	---
NAAQS *	---	---	---	188

* 5-Year Average



CPV Valley Energy Center
50 Braintree Hill Office Park
Suite 300
Braintree, MA 02184

ATTACHMENT 11

Emission Offsets



April 25, 2018

Mr. Ajay Shroff
New York State Department of Environmental Conservation
Division of Air Resources
625 Broadway
Albany, NY 12233-3254
Via Overnight Mail

RE: VOC ERC Transfer Package

Dear Mr. Shroff:

Please accept this request to transfer the intended use of 17.0 tons per year (tpy) of VOC emission reduction credits (ERCs) currently held by Arbill Incorporated (Arbill) to CPV Valley LLC (CPV). These VOC ERCs were created at Arbill's Philadelphia, Pennsylvania facility and are intended to be used toward CPV's Orange County, New York facility. Please allocate 17.0 tpy for use in this capacity and coordinate with Virandra Trivedi (or any person replacing him) at Pennsylvania Department of Environmental Protection for the transfer of use to CPV's draft permit.

Please note that BGC Environmental Brokerage Services (BGC) is hereby authorized to act on behalf of Arbill in the processing of the VOC ERC transfer. Please provide BGC (and us) a receipt upon acceptance of this transfer package. In addition, please provide BGC (and us) with the documentation related to the transfer. The mailing address for BGC is:

199 Water Street, 19th Floor
New York, NY 10038

We would appreciate if the request to transfer could be processed as expeditiously as possible. Thank you for your assistance in the processing of this ERC transfer request. If any questions arise, please feel free to call Lauren Kisting at (646) 346-6899 or Steve Ritter at (800) 523-3367.

Sincerely,

Thomas G. Strauss
Chief Financial Officer

CORPORATE HEADQUARTERS

10450 Drummond Road, Philadelphia, PA 19154 · 800-523-5367 · 800-426-5808 fax · info@arbill.com · www.arbill.com





CPV Valley Energy Center
50 Braintree Hill Office Park
Suite 300
Braintree, MA 02184

April 19, 2013

Mr. Ajay Stroff
New York State Department of Environmental Conservation
Division of Air Resource
625 Broadway
Albany, NY 12233-3254

Re: VOC ERC Transfer Package

Dear Mr. Stroff:

Please accept this request to transfer the intended use of 17.0 tons per year (tpy) of VOC emission reduction credits (ERCs) currently held by Arbill Incorporated (Arbill) to CPV Valley LLC (CPV). These VOC ERCs were created at Arbill's Philadelphia, Pennsylvania facility and are intended to be used toward CPV's Orange County, New York facility. Please allocate 17.0 tpy for use in this capacity and coordinate with Virendra Tivvedi at Pennsylvania Department of Environmental Protection for the transfer of use to CPV's draft permit.

Please note that BGC Environmental Brokerage Services (BGC) is hereby authorized to act on behalf of CPV in the processing of the VOC ERC transfer. Please provide BGC a receipt upon acceptance of this transfer package. In addition, please provide BGC with the documentation related to the transfer. The mailing address for BGC is:

199 Water Street, 19th Floor
New York, NY 10038

We would appreciate if the request to transfer could be processed as expeditiously as possible. Thank you for your assistance in the processing of this ERC transfer request. If any questions arise, please feel free to call Lauren Kisting at (646) 346-6899 or me at (781) 817-3970.

Best regards,

Steven P. Remillard
Vice President, Development

USE OF EMISSION REDUCTION CREDITS (ERC) FORM

FACILITY BROKER / USING PURCHASING ERC (Check Appropriate Boxes)

(Facility) / (Broker) Name CPV Valley Energy Center DEC ID# 3335600136

Address US RTE 6 (Section 2, Lots 36-37, 38-39, 40-22) Wawayanda, NY

Proposed Project Description A combined cycle natural gas powered generating facility

Contact Name Steve Remillard Phone # (781) 817-8970

Name of Authorized Representative Peter Podurgiel Title Senior Vice President

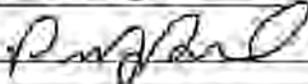
Signature of Authorized Representative  Date 4/19/2013

FACILITY BROKER / CREATING TRANSFERRING ERC (Check Appropriate Boxes)

(Facility) / (Broker) Name Arbill Industries, Inc. DEC ID# N/A

Address 2207 West Glenwood Avenue, Philadelphia, PA

ERC Emission Source ID#(s) / ERC tpy: 17.0 / _____

_____ OR

ERC Emission Unit ID#(s) / ERC tpy: _____

Reduction Mechanism: Facility Shutdown

Name of Authorized Representative: THOMAS G. SPRENGER Title: CFO

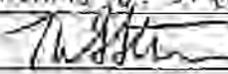
Signature of Authorized Representative  Date: 4/24/2013

AMOUNT OF EMISSION REDUCTION CREDIT BEING <input checked="" type="checkbox"/> USED / <input type="checkbox"/> TRANSFERRED					
(complete all that apply)					
offsets _____ tpy	NO _x	netting _____ tpy	offsets _____ tpy	PM-10	netting _____ tpy
offsets <u>17.0</u> tpy	VOC	netting _____ tpy	offsets _____ tpy	PM-2.5	netting _____ tpy
offsets _____ tpy	SO _x	netting _____ tpy			

***NOTE:** Any previous Use of ERC Forms associated with the ERCs being used or transferred with this transaction must be attached.



CPV Valley Energy Center
50 Braintree Hill Office Park
Suite 300
Braintree, MA 02184

April 26, 2013

Mr. Ajay Shroff
New York State Department of Environmental Conservation
Division of Air Resource
625 Broadway
Albany, NY 12233-3254

Re: VOC Transfer – Use of Emission Reduction Credits Form

Dear Mr. Shroff,

Please accept this request to transfer the intended use of 58.0 tons per year (tpy) of VOC emission reduction credits (ERCs) currently held by S. Walter Packaging Corp. (f/k/a Uniflex Holdings, Inc.) to CPV Valley, LLC (CPV). These VOC ERCs were created at Uniflex's Westbury, New York facility and are intended to be used toward CPV's Orange County, New York facility. Please allocate 58.0tpy for use in this capacity, and transfer use to CPV's draft permit. The Use of Emission Reduction Credits Form, signed by both parties, is enclosed herein to facilitate this transfer.

We would appreciate if the request to transfer could be processed as expeditiously as possible. Thank you for your assistance in the processing of this ERC transfer request. If any questions arise, please feel free to contact me at (781) 817-8972.

Best regards,

A handwritten signature in black ink that reads "Michael Bruno".

Michael T. Bruno
Manager, Development

Enclosures

CC: BGC Environmental Brokerage Services, L.P.
Attention: Lauren Kisling

Competitive Power Ventures, Inc
Attention: Steve Remillard

USE OF EMISSION REDUCTION CREDITS (ERC) FORM *

FACILITY BROKER / USING PURCHASING ERC (Check Appropriate Boxes)

(Facility) / (Broker) Name: CPV Valley Energy Center DEC ID#: 3335600136

Address: US RTE 6 (Section 4, Lots 38.32, 38.33, 40.22) Wawayanda, NY

Proposed Project Description: A combined cycle natural gas powered generating facility

Contact Name: Steve Remillard Phone #: (781) 817-8970

Name of Authorized Representative: Peter Podurgiel Title: Senior Vice President

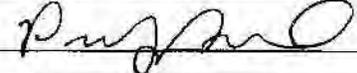
Signature of Authorized Representative:  Date: 4/19/2013

FACILITY BROKER / CREATING TRANSFERRING ERC (Check Appropriate Boxes)

S. Walter Packaging Corp. (f/k/a Uniflex Holdings, Inc.)
 (Facility) / (Broker) Name: _____ DEC ID#: 1-2822-00367

Address: 474 GRAND BLVD, WESTBURY, NY 11590

ERC Emission Source ID#(s) / ERC tpy: 58.0 / _____ ; _____ / _____ ; _____

_____ / _____ ; _____ / _____ ; OR

ERC Emission Unit ID#(s) / ERC tpy: _____ / _____ ; _____ / _____ ; _____

_____ / _____ ; _____ / _____ ;

Reduction Mechanism: Facility Shutdown

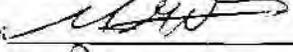
Name of Authorized Representative:  Title: CHIEF FINANCIAL OFFICER

Signature of Authorized Representative: RICHARD GETLEIN Date: 4/24/2013

AMOUNT OF EMISSION REDUCTION CREDIT BEING				■ USED / □ TRANSFERRED	
(complete all that apply)					
offsets _____ tpy	NO _x	netting _____ tpy	offsets _____ tpy	PM-10	netting _____ tpy
offsets <u>58.0</u> tpy	VOC	netting _____ tpy	offsets _____ tpy	PM-2.5	netting _____ tpy
offsets _____ tpy	SO ₂	netting _____ tpy			

***NOTE:** Any previous Use of ERC Forms associated with the ERCs being used or transferred with this transaction must be attached.



CPV Valley Energy Center
50 Braintree Hill Office Park
Suite 300
Braintree, MA 02184

April 19, 2013

Mr. Ajay Shroff
New York State Department of Environmental Conservation
Division of Air Resource
625 Broadway
Albany, NY 12233-3254

Re: NOx ERC Transfer Package

Dear Mr. Shroff:

Please accept this request to transfer 216.0 tons per year (tpy) of NOx emission reduction credits (ERCs) currently held by Sony Electronics, Inc. to CPV Valley LLC (CPV). These NOx ERCs were created at Sony's 777 Technology Drive, Mt. Pleasant, Pennsylvania facility and will be used toward CPV's Orange County, New York facility. Please allocate 216.0 tpy for use in this capacity and coordinate with Virendra Trivedi at Pennsylvania Department of Environmental Protection for the transfer to CPV's draft permit.

Please note that BGC Environmental Brokerage Services (BGC) is hereby authorized to act on behalf of CPV in the processing of the VOC ERC transfer. Please provide BGC a receipt upon acceptance of this transfer package. In addition, please provide BGC with the documentation related to the transfer. The mailing address for BGC is:

199 Water Street, 19th Floor
New York, NY 10038

We would appreciate if the request to transfer could be processed as expeditiously as possible. Thank you for your assistance in the processing of this ERC transfer request. If any questions arise, please feel free to call Lauren Kisling at (646) 346-6899 or me at (781) 817-8970.

Best regards,

A handwritten signature in black ink, appearing to read "Steven P. Remillard". The signature is fluid and cursive.

Steven P. Remillard
Vice President, Development

USE OF EMISSION REDUCTION CREDITS (ERC) FORM *

FACILITY BROKER / USING PURCHASING ERC (Check Appropriate Boxes)

(Facility) / (Broker) Name: CPV Valley Energy Center DEC ID#: 3335600136

Address: US RTE 6 (Section 4, Lots 38.32, 38.33, 40.22) Wawayanda, NY

Proposed Project Description: A combined cycle natural gas powered generating facility

Contact Name: Steve Remillard Phone #: (781) 817-8970

Name of Authorized Representative: Peter Podurgiel Title: Senior Vice President

Signature of Authorized Representative:  Date: 4/19/2013

FACILITY BROKER / CREATING TRANSFERRING ERC (Check Appropriate Boxes)

(Facility) / (Broker) Name: Sony Electronics, Inc. DEC ID#: _____

Address: 777 Technology Dr, Mt. Pleasant located in Pennsylvania

ERC Emission Source ID#(s) / ERC tpy: 216.0 / _____ ; _____ ; _____ ;

_____ / _____ ; _____ / _____ ; **OR**

ERC Emission Unit ID#(s) / ERC tpy: _____ / _____ ; _____ / _____ ;

_____ / _____ ; _____ / _____ ;

Reduction Mechanism: Shutdown Vice President Finance & Accounting

Name of Authorized Representative: Chris Goodman Title: _____

Signature of Authorized Representative:  Date: 4/26/13

AMOUNT OF EMISSION REDUCTION CREDIT BEING				<input checked="" type="checkbox"/> USED / <input type="checkbox"/> TRANSFERRED	
(complete all that apply)					
offsets <u>216.0</u> tpy	NO _x	netting _____ tpy	offsets _____ tpy	PM-10	netting _____ tpy
offsets _____ tpy	VOC	netting _____ tpy	offsets _____ tpy	PM-2.5	netting _____ tpy
offsets _____ tpy	SO ₂	netting _____ tpy			

***NOTE:** Any previous Use of ERC Forms associated with the ERCs being used or transferred with this transaction must be attached.

SONY

Sony Electronics Inc.
18530 Via Esprillo, San Diego, California 92127

April 26, 2013

New York State Department of Environmental Conservation
Division of Air Resource
Attn: Mr. Ajay Shroff
625 Broadway
Albany, NY 12233-3254
Via Overnight Mail

RE: NOx ERC Transfer Package

Dear Mr. Shroff:

Please accept this request to transfer 216.0 tons per year (tpy) of NOx emission reduction credits (ERCs) currently held by American Video Glass LLC (Sony Electronics Inc.) to CPV Valley LLC (CPV). These NOx ERCs were created at 777 Technology Dr, Mt. Pleasant Pennsylvania facility and will be used toward CPV's Orange County, New York facility. Please allocate 216.0 tpy for use in this capacity and coordinate with Virendra Trivedi at Pennsylvania Department of Environmental Protection for the transfer to CPV's draft permit.

Please note that BGC Environmental Brokerage Services (BGC) is hereby authorized to act on behalf of Arbill in the processing of the NOx ERC transfer. Please provide BGC (and us) a receipt upon acceptance of this transfer package. In addition, please provide BGC (and us) with the documentation related to the transfer. The mailing address for BGC is:

199 Water Street, 19th Floor
New York, NY 10038

We would appreciate if the request to transfer could be processed as expeditiously as possible. Thank you for your assistance in the processing of this ERC transfer request. If any questions arise, please feel free to call Lauren Kisling at (646) 346-6899 or Christopher Goodman at (858) 942-2005.

Sincerely,



Chris Goodman
Vice President
Finance & Accounting



April 25, 2013

Mr. Virendra Trivedi
Chief
Pennsylvania Department of Environmental Protection
NSR Section, Division of Permits, Bureau of Air Quality
Rachel Carson State Office Building
400 Market Street
Harrisburg, PA 17101
Via Overnight Mail

RE: VOC ERC Transfer Package

Dear Mr. Trivedi:

Please accept this request to transfer 17.0 tons per year (tpy) of VOC emission reduction credits (ERCs) currently held by Arbill Industries, Inc. (Arbill) for use by CPV Valley LLC (CPV) at its Orange County, New York facility. These VOC ERCs were created at Arbill's Philadelphia, Pennsylvania facility. Please allocate 17.0 tpy for use in this capacity and coordinate with Mr. Ajay Shroff (or any person replacing him) at New York State Department of Environmental Conservation for the use as part of CPV's draft permit.

Please note that BGC Environmental Brokerage Services (BGC) is hereby authorized to act on behalf of CPV in the processing of the VOC ERC transfer, including this request. Please provide BGC a receipt upon acceptance of this transfer package. In addition, please provide BGC with the documentation relating to this transfer. The mailing address for BGC is:

199 Water Street, 19th Floor
New York, NY 10038

We would appreciate if the request to transfer could be processed as expeditiously as possible. Thank you for your assistance in the processing of this ERC transfer request. If any questions arise, please feel free to call Lauren Kising at (646) 346-8899 or Steve Remillard at (761) 817-8970.

Sincerely,

Thomas G. Strauss
Chief Financial Officer





CPV Valley Energy Center
50 Braintree Hill Office Park
Suite 300
Braintree, MA 02154

April 19, 2017

Mr. Vinendra Trivedi
Chief

Pennsylvania Department of Environmental Protection
NSR Section, Division of Permits, Bureau of Air Quality
Rachel Carson State Office Building
400 Market Street | Harrisburg, PA

Re: VOC ERC Transfer Package

Dear Mr. Trivedi:

Please accept this request to transfer 17.0 tons per year (tpy) of VOC emission reduction credits (ERCs) currently held by Arbill Industries, Inc. (Arbill) for the intended use of CPV Valley LLC (CPV) at its Orange County, New York facility. These VOC ERCs were created at Arbill's Philadelphia, Pennsylvania facility. Please allocate 17.0 tpy for use in this capacity and coordinate with Mr. Ajay Shroff at New York State's Department of Environmental Conservation for the transfer to CPV's draft permit.

Please note that BGC Environmental Brokerage Services (BGC) is hereby authorized to act on behalf of CPV in the processing of the VOC ERC transfer. Please provide BGC a receipt upon acceptance of this transfer package. In addition, please provide BGC with the documentation related to the transfer. The mailing address for BGC is:

197 Water Street, 19th Floor
New York, NY 10038

We would appreciate if the request in transfer could be processed as expeditiously as possible. Thank you for your assistance in the processing of this ERC transfer request. If any questions arise, please feel free to call Lauren Kisling at (646) 346-5899 or me at (781) 817-8970.

Best regards,

Steven B. Remillard
Vice President, Development



CPV Valley Energy Center
50 Braintree Hill Office Park
Suite 300
Braintree, MA 02184

April 19, 2013

Mr. Virendra Trivedi
Chief
Pennsylvania Department of Environmental Protection
NSR Section, Division of Permits, Bureau of Air Quality
Rachel Carson State Office Building
400 Market Street | Harrisburg, PA

Re: NOx ERC Transfer Package

Dear Mr. Trivedi:

Please accept this request to transfer 216.0 tons per year (tpy) of NOx emission reduction credits (ERCs) currently held by Sony Electronics, Inc. to CPV Valley LLC (CPV). These NOx ERCs were created at Sony's 777 Technology Drive, Mt. Pleasant, Pennsylvania facility and will be used toward CPV's Orange County, New York facility. Please allocate 216.0 tpy for use in this capacity and coordinate with Mr. Ajay Shroff at New York State's Department of Environmental Conservation for the transfer to CPV's draft permit.

Please note that BGC Environmental Brokerage Services (BGC) is hereby authorized to act on behalf of CPV in the processing of the VOC ERC transfer. Please provide BGC a receipt upon acceptance of this transfer package. In addition, please provide BGC with the documentation related to the transfer. The mailing address for BGC is:

199 Water Street, 19th Floor
New York, NY 10038

We would appreciate if the request to transfer could be processed as expeditiously as possible. Thank you for your assistance in the processing of this ERC transfer request. If any questions arise, please feel free to call Lauren Kisling at (646) 346-6899 or me at (781) 817-8970.

Best regards,

Steven P. Remillard
Vice President, Development

SONY

Sony Electronics Inc.
16530 Via Esprillo, San Diego, California 92127

April 26, 2013

Pennsylvania Department of Environmental Protection
Attn: Virendra Trivedi
400 Market Street
12th Floor
Harrisburg, PA 17101
Via Overnight Mail

RE: NOx ERC Transfer Package

Dear Mr. Trivedi:

Please accept this request to transfer 216.0 tons per year (tpy) of NOx emission reduction credits (ERCs) currently held by American Video Glass LLC (Sony Electronics Inc.) to CPV Valley LLC (CPV). These NOx ERCs were created at 777 Technology Dr, Mt. Pleasant Pennsylvania facility and will be used toward CPV's Orange County, New York facility. Please allocate 216.0 tpy for use in this capacity and coordinate with Mr. Ajay Shroff [or any person replacing him] at New York State's Department of Environmental Conservation for the transfer to CPV's draft permit.

Please note that BGC Environmental Brokerage Services (BGC) is hereby authorized to act on behalf of CPV in the processing of the NOx ERC transfer. Please provide BGC a receipt upon acceptance of this transfer package. In addition, please provide BGC with the documentation relating to this transfer. The mailing address for BGC is:

199 Water Street, 19th Floor
New York, NY 10038

We would appreciate if the request to transfer could be processed as expeditiously as possible. Thank you for your assistance in the processing of this ERC transfer request. If any questions arise, please feel free to call Lauren Kisling at (646) 346-6899 or Christopher Goodman at (858) 942-2005.

Sincerely,



Chris Goodman
Vice President
Finance & Accounting